



ENTRO



EDF – Generation and Engineering
Division
73 373
Le Bourget du Lac Cedex
France
Tel: +33-4-79 60 60 28
Fax: +33-4-79 60 62 35
eMail: pierre.brun@edf.fr
<http://www.edf.fr>

EASTERN NILE POWER TRADE PROGRAM STUDY

AfDB



Scott Wilson
Kanthack House, Station Road,
Ashford, Kent TN 23 1 PP
England
Tel: +44 (0) 1233 658200
Fax: +44 (0) 1233 658209
eMail: alan.bates@scottwilson.com
<http://www.scottwilson.com>

ENERGY SECTOR PROFILE & PROJECTIONS

VOL 5

with participation of:

- EPS (Egypt)
- Tropics (Ethiopia)
- YAM (Sudan)

FINAL MAIN REPORT

June 2007



TABLE OF CONTENTS

1. OVERVIEW.....	9
1.1 FUEL PRICE PROJECTIONS	9
1.2 INTERCONNECTION VIEWS FOR THE INTERCONNECTED SYSTEM	9
1.3 FIRST INDICATIONS OF THE PROFITABILITY OF THE INTERCONNECTION.....	11
2. ORGANISATION OF THE REPORT	13
3. FUEL PRICE PROJECTIONS.....	14
3.1.1 <i>International Crude oil price</i>	14
3.1.1.1 Overview.....	14
3.1.1.2 Oil price projections considered for the study.....	16
3.1.2 <i>Natural gas price</i>	18
3.1.2.1 Overview	18
3.1.2.2 Natural Gas price projections considered in the study	19
3.1.3 <i>Coal price</i>	21
3.1.3.1 Overview.....	21
3.1.3.2 Coal price projections considered in the study	21
3.1.4 <i>Price of oil derivatives</i>	22
3.1.5 <i>Net Calorific value</i>	22
3.1.6 <i>Energy Units and Conversion factor</i>	23
4. OPTIONS FOR THE INTERCONNECTED SYSTEM	24
4.1 GENERATION CANDIDATES FOR THE INTERCONNECTED SYSTEM	24
4.2 INTERCONNECTION OPTIONS FOR THE INTERCONNECTED SYSTEM.....	24
4.2.1 <i>Identification of the Interconnection views</i>	24
4.2.1.1 Presentation.....	24
4.2.1.2 Main characteristics of the views	25
4.2.2 <i>Identification of the interconnection points and the possible line routes</i>	26
4.2.2.1 THE INTERCONNECTION VIEWS.....	26
4.2.2.2 The possible line routes.....	27
4.2.2.2.1 Presentation	27
4.2.2.2.2 Line route of the AC view A1 & A2.....	27
4.2.2.2.3 Line route of the DC views A3 (A3a and A3b)	31
4.2.3 <i>Identification of typical nominal costs (investment cost per km of line, converter station cost, etc)</i> 34	
4.2.3.1 General economic hypothesis	34
4.2.3.2 VIEW A1: 500 kV AC SINGLE CIRCUIT LINE.....	34
4.2.3.2.1 Description.....	34
4.2.3.2.2 Interconnection Cost.....	36
4.2.3.3 VIEW A2: 500 kV AC DOUBLE CIRCUIT LINE.....	38
4.2.3.3.1 Description.....	38
4.2.3.3.2 Interconnection cost	41
4.2.3.4 VIEWS A3: +/- 500 kV DC DOUBLE POLE LINK	44
4.2.3.4.1 Description View A3a: without DC/AC substation in Sudan.....	44
4.2.3.4.2 Interconnection Cost of View A3a	46
4.2.3.4.3 Description Alternatives A3b: with DC/AC substation in Sudan.....	48
4.2.3.4.4 Interconnection cost of View A3b	49
4.2.3.5 Reference unit cost.....	53
4.3 CONCLUSION	59
5. FIRST INDICATIONS OF ECONOMIC PROFITABILITY OF EXPORTS TO EGYPT.....	60
5.1 INTRODUCTION.....	60
5.2 LOAD FACTOR OF THE INTERCONNECTION.....	62
5.3 ECONOMIC COST OF GAS-FIRED CCGT IN EGYPT	62
5.4 ECONOMIC COST OF HYDRO POWER DELIVERED TO EGYPT.....	65
5.4.1 <i>Economic cost of HPP</i>	65
5.4.2 <i>Economic cost of the interconnection</i>	65
5.5 DISCUSSION	65
5.5.1 <i>Exports from a 40 USD/MWh HPP and 12% discount rate</i>	66

Module M3: Energy Sector Profile & Projections

Vol 5

5.5.2	<i>Exports from a 35 USD/MWh HPP and 10% discount rate</i>	67
5.5.3	<i>Impact of demand projections on the interconnection profitability.....</i>	68
5.6	CONCLUSION	69

LIST OF TABLES

TABLE 3.1.1-1 - OIL PRICE PROJECTIONS	9
TABLE 3.1.1-2 - NATURAL GAS PRICE PROJECTIONS	9
TABLE 3.1.1-1 - FIRST VIEWS OF INTERCONNECTION COSTS AND CHARACTERISTICS.....	10
TABLE 3.1.1-1 - CRUDE OIL WORLD PRICE PROJECTIONS.....	17
TABLE 3.1.2-1 - NATURAL GAS PRICE PROJECTION.....	20
TABLE 3.1.5-1 - TYPICAL NET CALORIFIC VALUES.....	22
TABLE 3.1.5-2 - NET CALORIFIC VALUES USED IN THE STUDY.....	23
TABLE 4.2.3-1 - VIEW A1: 500 kV AC SINGLE CIRCUIT LINE – INVESTMENT COSTS	37
TABLE 4.2.3-2 - VIEW A1: 500 kV AC SINGLE CIRCUIT LINE - COST OF LOSSES	38
TABLE 4.2.3-3 - VIEW A1: 500 kV AC SINGLE CIRCUIT LINE - O&M COSTS	38
TABLE 4.2.3-4 - VIEW A2: 500 kV AC DOUBLE CIRCUIT LINE - INVESTMENT COSTS	42
TABLE 4.2.3-5 - VIEW A2: 500 kV AC DOUBLE LINE – COST OF LOSSES	43
TABLE 4.2.3-6 - VIEW A2: 500 kV AC DOUBLE CIRCUIT LINE - O&M COSTS.....	43
TABLE 4.2.3-7 - VIEW A3A: ± 500 kV DC DOUBLE POLE LINE – INVESTMENT COSTS.....	47
TABLE 4.2.3-8 - VIEW A3A: ± 500 kV DOUBLE POLE LINE – COST OF LOSSES.....	47
TABLE 4.2.3-9 - VIEW A3A: ± 500 kV DOUBLE POLE LINE – O&M COSTS	47
TABLE 4.2.3-10 - ETHIOPIAN SUBSTATION AND LINE FROM ETHIOPIA TO SUDAN	51
TABLE 4.2.3-11 - SUDAN TAPPING SUBSTATION	51
TABLE 4.2.3-12 - EGYPTIAN SUBSTATION AND LINE FROM SUDAN TO EGYPT	52
TABLE 4.2.3-13 - VIEW A3B: ± 500 kV DC DOUBLE POLE LINE – INVESTMENT COSTS.....	52
TABLE 4.2.3-14 - VIEW A3B: ± 500 kV DOUBLE POLE LINE – COST OF LOSSES	52
TABLE 4.2.3-15 - VIEW A3B: ± 500 kV DOUBLE POLE LINE – O&M COSTS	53
TABLE 4.2.3-16 - OPERATION AND MAINTENANCE COSTS	53
TABLE 4.2.3-17 - AC TRANSMISSION EQUIPMENT UNIT COSTS	54
TABLE 4.2.3-18 - DC TRANSMISSION EQUIPMENT UNIT COSTS	55
TABLE 4.2.3-19 - CALCULATION OF INTEREST DURING CONSTRUCTION (IDC).....	58
TABLE 4.2.3-1 - ECONOMIC CHARACTERISTICS OF THE GENERIC GAS-FIRED CCGT IN EGYPT.....	63
TABLE 5.4.2-1 - ECONOMIC COST OF THE INTERCONNECTION OPTIONS.....	65

LIST OF FIGURES

FIGURE 1.3-1 - HISTORICAL EVOLUTION OF BRENT CRUDE OIL PRICE 14

FIGURE 1.3-2 - HISTORICAL OIL PRICE EVOLUTION FROM 1980 15

FIGURE 1.3-3 - WORLD OIL PRICE PROJECTIONS 17

FIGURE 1.3-4 - HISTORICAL PRICE OF NATURAL GAS 18

FIGURE 1.3-5 - MAJOR NATURAL GAS TRADE MOVEMENT 19

FIGURE 1.3-6 - NATURAL GAS PRICE PROJECTIONS FOR THE EUROPEAN AND AFRICAN MARKET..... 20

FIGURE 1.3-7 - HISTORICAL PRICE OF COAL..... 21

FIGURE 4.2-1 - AC VIEWS A1 & A2: LINE ROUTE BETWEEN HIGH DAM AND MEROWE 28

FIGURE 4.2-2 - AC VIEW A LINE ROUTE BETWEEN HASAHEISA - BORDER HPP 29

FIGURE 4.2-3 - VIEW A2 LINE ROUTE BETWEEN HASAHEISA - MANDAYA HPP 30

FIGURE 4.2-4 - DC VIEW A3: LINE ROUTE BETWEEN ASSIUT - MANDAYA HPP (BETWEEN ASSIUT AND DONGOLA)... 32

FIGURE 4.2-5 - DC VIEW A3 - LINE ROUTE (BETWEEN DONGOLA AND MANDAYA HPP)..... 33

FIGURE 4.2-6 - VIEW A1 - 500 KV AC SINGLE CIRCUIT LINE 35

FIGURE 4.2-7- VIEW A2 - 500 KV DOUBLE CIRCUIT LINE 40

FIGURE 4.2-8 - VIEW A3A: ± 500 kV DC LINE, WITHOUT DC/AC SUBSTATION IN SUDAN..... 45

FIGURE 4.2-9 - VIEW A3B: ± 500 kV DC LINE, WITH DC/AC SUBSTATION IN SUDAN..... 49

FIGURE 5.3-1 - ECONOMIC COST OF GENERIC GAS-FIRED CCGT IN EGYPT..... 64

FIGURE 5.5-1 - COMPARISON OF COST BETWEEN CCGT AND HYDROPOWER SUPPLIED TO EGYPT – 12% DISCOUNT
RATE 66

FIGURE 5.5-2 - COMPARISON OF COST BETWEEN CCGT AND HYDROPOWER SUPPLIED TO EGYPT – 10% DISCOUNT
RATE 67

PHYSICAL UNITS AND CONVERSION FACTORS

bbbl	barrel	(1t = 7.3 bbl)
cal	calorie	(1 cal = 4.1868 J)
Gcal	Giga calorie	
GWh	Gigawatt-hour	
h	hour	
km	kilometer	
km ²	square kilometer	
kW	kilo Watt	
kWh	kilo Watt hour	(1 kWh = 3.6 MJ)
MBtu	Million British Thermal Units	(= 1 055 MJ = 252 kCal)
	one cubic foot of natural gas produces approximately 1,000 BTU	
MJ	Million Joule	(= 0,948.10 ⁻³ MBtu = 238.8 kcal)
MW	Mega Watt	
m	meter	
m ³ /d	cubic meter per day	
mm	millimeter	
mm ³	million cubic meter	
Nm ³	Normal cubic meter, i.e. measured under normal conditions, i.e. 0°C and 1013 mbar	(1 Nm ³ = 1.057 m ³ measured under standard conditions, i.e. 15°C and 1013 mbar)
t	ton	
toe	tons of oil equivalent	
tcf	ton cubic feet	
°C	Degrees Celsius	

ABBREVIATIONS AND ACRONYMS

ADB	African Development Bank
ADF	African Development Fund
CC	Combined Cycle
CCGT	Combined Cycle Gas Turbine
CIDA	Canadian International Development Agency
CT	Combustion Turbine
DANIDA	Danish Development Assistance
DFID	Department for International Development (UK)
DIDC	Department for International Development Cooperation (GoF)
DSA	Daily Subsistence Allowance
EEHC	Egyptian Electricity Holding Company
EEPCO	Ethiopian Electric Power Corporation
EHV	Extra High Voltage
EHVAC	Extra High Voltage Alternating Current
EIA	Environmental Impact Assessment
EIRR	Economic Internal Rate of Return
EN	Eastern Nile
ENCOM	Eastern Nile Council of Ministers
ENSAP	Eastern Nile Subsidiary Action Program
ENSAPT	Eastern Nile Subsidiary Action Program Team
ENTRO	Eastern Nile Technical Regional Office
ENTRO PCU	Eastern Nile Technical Regional Office Power Coordination Unit
FIRR	Financial Internal Rate of Return
GEP	Generation Expansion Plan
GTZ	German Technical Co-operation
HPP	Hydro Power Plant
HFO	Heavy fuel oil
HV	High Voltage
HVDC	High Voltage Direct Current
ICCON	International Consortium for Cooperation on the Nile
ICS	Interconnected System
IDEN	Integrated Development of the Eastern Nile
IDO	Industrial Diesel Oil
IMF	International Monetary Fund
JICA	Japanese International Co-operation Agency
JMP	Joint Multipurpose Project
LNG	Liquefied Natural Gas
LOLP	Loss of Load Probability
LPG	Liquefied Petroleum Gas

LRFO	Light Residual Fuel Oil
MENA	Middle East, North Africa Countries
MIWR	Ministry of Irrigation & Water Resources (Sudan)
MWR	Ministry of Water Resources (Ethiopia)
MWRI	Ministry of Water Resources and Irrigation (Egypt)
MSD	Medium Speed Diesel (TPP)
NBI	Nile Basin Initiative
NEC	National Electricity Corporation (Sudan)
NECC	National Electricity Control Centre (Egypt)
NELCOM	Nile Equatorial Lake Council of Ministers
NELSAP	Nile Equatorial Lake Subsidiary Action Program
NG	Natural Gas
NGO	Non Governmental Organization
NORAD	Norwegian Aid Development
NPV	Net Present Value
O&M	Operations and Maintenance
OCGT	Open Cycle Gas Turbine
OPEC	Organization of the Petroleum Exporting Countries
PBP	Pay Back Period
PHRD	Policy & Human Resource Development Fund
PIU	Project Implementation Unit
PRSP	Poverty Reduction Strategy Paper
RCC	Regional Electricity Control Centre (Egypt)
RE	Rural Electrification
SAPP	Southern Africa Power Pool
SIDA	Swedish International Development Agency
SSD	Slow speed diesel (TPP)
STPP	Steam Turbine Power Plant
STS	Senior Technical Specialist
TAF	Technical Assistant Fund
TPP	Thermal Power Plant
UA	Unit of Account
UNDP	United Nations Development Program
WB	World Bank

1. OVERVIEW

1.1 FUEL PRICE PROJECTIONS

The Consultant find relevant to use the following international fuel price projections:

- Oil price projections from the Energy Information Administration (AEO 2006):

Unit : 2006 USD/bbl

Scenario	2006	2007	2008	2009	2010	2015	2020	2025	2030
High	62.0	62.2	62.8	64.1	65.7	80.0	89.2	94.7	100.4
Reference	62.0	58.3	54.9	52.6	49.6	50.1	53.2	56.7	59.8
Low	62.0	56.5	51.3	47.1	42.3	35.4	35.7	36.1	35.4

Table 3.1.1-1 - Oil price projections

- Natural gas projections from the European Commission for the European and African market:

Unit : USD₂₀₀₆/MBTU

Scenario	2006	2010	2015	2020	2025	2030
High	6.5	6.4	7.4	7.9	9.0	10.5
Reference	6.5	6.4	6.4	7.0	8.1	8.4
Low	6.5	4.8	4.9	5.0	5.1	6.6

Table 3.1.1-2 - Natural gas price projections

- The coal price is considered constant all over the study period: 63 USD/t.

1.2 INTERCONNECTION VIEWS FOR THE INTERCONNECTED SYSTEM

Four views have been selected to interconnect the systems, two AC options and two DC options. The interconnection points are the following:

- In Egypt: High Dam for the AC alternatives and Assiut for the DC alternative.
- In Ethiopia: Border HPP and Mandaya HPP for the AC alternatives and Mandaya HPP for the DC alternatives.
- In Sudan: Merowe HPP and Hasaheisa 500 kV substation for AC views. One DC view passes through Sudan without tapping station, the other one with a tapping station in Khartoum (Markhiat 500 kV substation).

View A1:

Consists in a 500 kV AC single circuit line between High Dam and Merowe and between Hasaheisa and Border HPP. One 500/400 kV 660 MVA transformer is installed at Border HPP. The power exchange, equal to 600 MW, is not guaranteed in N-1 situation.

View A2:

Consists in a 500 kV AC double circuit line between High Dam and Merowe and between Hasaheisa and Mandaya HPP. Two 500/400 kV 555 MVA transformers are installed at Mandaya HPP. The 500kV Egyptian system is reinforced with a 500 kV single circuit line High Dam-Assiut. The power exchange, equal to 1 000 MW, is guaranteed in N-1.

View A3a:

Consists in a \pm 500 kV double pole line between Mandaya HPP and Assiut. One AC/DC 1 200 MW converter is installed at Mandaya and one at Assiut. The power exchange is equal to 1 200 MW, only 600 MW are guaranteed in N-1.

View A3b:

Same as A3a but with a DC/AC tapping station located at Khartoum (300 MW), the station in Assiut is reduced to 900 MW.

The investment cost of the three alternatives and the transmission cost per MWh have been calculated, based on the following hypothesis:

- Duration of the power exchange = 5 000 hours/year.
- Cost of losses = 40 \$/MWh.
- Discount rate = 10-12%.

The results are displayed in the following table:

	V A1	V A2	V A3a	V A3b
Voltage	500 kV AC	500 kV AC	\pm 500 kV DC	\pm 500 kV DC
Investment cost	465 MUSD	1 025 MUSD	760 MUSD (no substation in Sudan)	764 MUSD DC/AC substation in Sudan
Transmission cost	24.4 USD/MWh	30.6 USD/MWh	21.9 USD/MWh	28.2 USD/MWh
Transfer capacity in N situation	600 MW	1 000 MW	1 200 MW	1 200 MW (Sudan 300 MW Egypt 900 MW)
Transfer capacity in N-1 situation	0 MW	1 000 MW	600 MW	600 MW

Table 3.1.1-1 - First views of interconnection costs and characteristics

These results confirm that to transmit a huge power over a long distance, such as between Ethiopia and Egypt, DC solutions are the less expensive ones.

For the coming step of the study, Module 6, other alternatives – connection points, line route and technical characteristics - will be investigated. They will be designed according to the results of the economic study - power exchange, duration of exchange and the HPP location. In particular, a mix solution, combining AC and DC links, could be considered.

1.3 FIRST INDICATIONS OF THE PROFITABILITY OF THE INTERCONNECTION

The profitability of the power exports from the Ethiopia - Sudan area to Egypt is determined by the competition between gas-fired CCGT in Egypt and hydro power supplied to Egypt through the interconnection. The interconnection is economically founded if the average cost of the MWh supplied to Egypt through the interconnection is lower than the average cost of the MWh directly supplied by a gas-fired CCGT in Egypt.

From the previous first views of interconnection options and costs, it is possible to compare:

- the economic cost of gas-fired Egyptian CCGT generation,
- the economic cost of hydro generation supplied to Egypt through the interconnection.

The economic costs of generation and transmission depend on investment cost, operation cost (fuel and O&M) and also on discount rate. A high value of discount rate would give more weight to short term, and would disfavour large and long term investments (e.g. HPP and interconnection) compared to lower investments with short economic lives (e.g. CCGT).

The reference discount rate for the economic Study carried out in Module 6 is 10% (see justification in Module 4). A 12% rate will be considered in the sensitivity analysis.

From the first views of the interconnection (technology, route, capacity, etc), it is found that:

- For the reference discount rate used in this Study (10%), power exports from Ethiopia – Sudan area supplied from a 35 USD/MWh HPP (typical value of the lowest cost HPP identified in Module 3 Vol 3 and 4), would become competitive when the natural gas price in Egypt is greater than a range of 5.0 to 5.5 USD/MBTU. This value is significantly exceeded in the 2015, which is the earliest date of commissioning of the interconnection, in both reference and high projection of natural gas price. This means that the interconnection would become profitable from its earliest possible date of commissioning.

If the natural gas price remains low, economic profitability of power export to Egypt from a 35 USD/MWh HPP would not be achieved before 2025-2030, even for the lowest cost interconnection options.

- For a 12% discount, which could be considered as a conservative value, the typical value of the lowest cost HPP is 40 USD/MWh in the Sudan / Ethiopia area. Hydro power exports would become competitive when the price of natural gas in Egypt is greater than a range of 6.0 to 6.2 USD/MBTU.

This value is exceeded in the 2015, for the two lower cost options identified for the interconnection for both high and reference natural gas price projection. In the high price gas projection, the most expensive interconnection option, 500 kV AC 1 000 MW, would become competitive from about 2015.

If the natural gas price remains low, then it is not possible to expect any economic profitability of power export to Egypt from a 40 USD/MWh HPP, even in 2030.

Module M3: Energy Sector Profile & Projections

Vol 5

At this stage of the Study, these figures and results are to be considered as purely indicative because they are based on a simplified economic approach, preliminary identification of interconnection alternatives. Nevertheless they strongly support the confidence in the profitability of the interconnection from 2015.

The purpose of Module 6, through the economic study, generation expansion plan determination and interconnection optimisation (design and line route), will be to confirm this economic profitability and to precisely assess the associated benefits for the region.

2. ORGANISATION OF THE REPORT

Module 3 deals with the future evolution of the demand and identification of supply and interconnection options. The findings of this Module will constitute the base on which the regional investment plan will be determinate.

This Module is organized in five Volumes:

- Volume 1: Executive summary of Module M3
- Volume 2: Energy Sector Profile & Projections for Egypt
 - Review and update of previous demand forecast.
 - Potential trade opportunities.
 - Review of the existing Generation Expansion Plan.
 - Identification of generation supply options.
 - Review of existing transmission master plan.
- Volume 3: Energy Sector Profile & Projections for Ethiopia
 - Review and update of previous demand forecast.
 - Potential trade opportunities.
 - Review of the existing Generation Expansion Plan.
 - Identification of generation supply options.
 - Review of existing transmission master plan.
- Volume 4: Energy Sector Profile & Projections for Sudan
 - Review and update of previous demand forecast.
 - Potential trade opportunities.
 - Review of the existing Generation Expansion Plan.
 - Identification of generation supply options.
 - Review of existing transmission master plan.
- Volume 5:
 - Fuel prices Projections.
 - Interconnection options.
 - First evaluation of economic profitability of exports from Sudan-Ethiopia.

The present Volume 5 is focussed on the international fuel prices projections, the description on the interconnection options between Ethiopia, Egypt, and Sudan, and presents a first evaluation of the economic profitability of exports from the Sudan-Ethiopia area to Egypt.

3. FUEL PRICE PROJECTIONS

Fuel price projections are one of the key hypothesis of the Study. Fuel prices directly impact the profitability of the interconnection between Ethiopia, Egypt and Sudan. High fossil fuel prices will increase the attractiveness of hydro plant with respect to thermal plant. While low fuel price might turn the interconnection non profitable.

While the main fossil fuel in competition with Sudanese or Ethiopian Hydro Power Plant is Egyptian Natural Gas fired in Egyptian CCGT, this paragraph will also provide projection for Crude Oil and Coal prices.

The prices considered in this paragraph are the frontier prices. The transport cost to each TPP inside each country is discussed and established in the relevant paragraphs associated to each country (see relevant chapters in Vol 2-3-4 of M3 report)

3.1.1 INTERNATIONAL CRUDE OIL PRICE

3.1.1.1 Overview

The base commodity for evaluating the cost of the refined fuels used in the power sector (HFO, Diesel, etc) is crude oil. After periods of relative stability, with a price around 15 to 20 USD/barrel, world oil markets have been extremely volatile or the past several years:

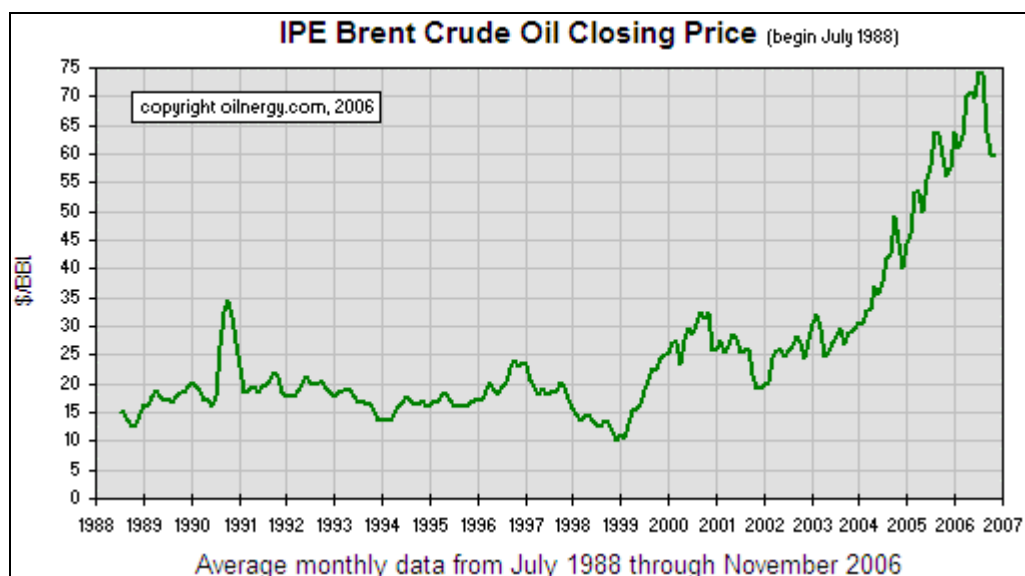

Figure 1.3-1 - Historical evolution of Brent crude oil price

An look at earlier period shows that oil prices reached values higher, and for longer period, than presently experienced (1974: Kippur war, 1980: Iran revolution, etc):

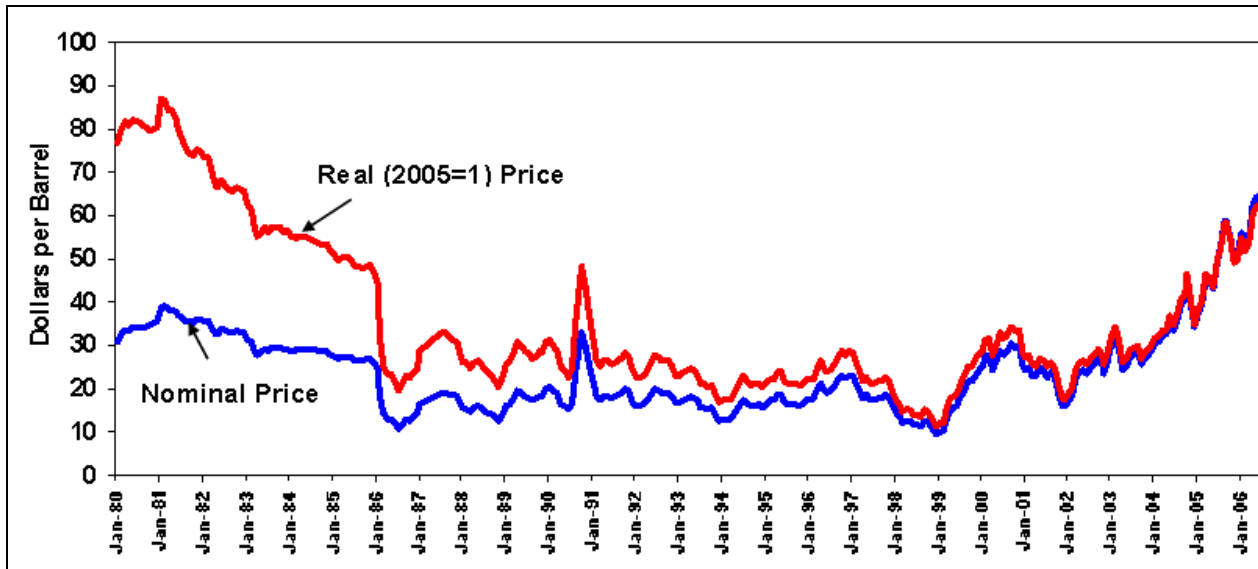

Figure 1.3-2 - Historical oil price evolution from 1980

Origin: ENERGY INFORMATION ADMINISTRATION

The evolution of the oil market price is mainly driven by different factors:

- evolution of the world oil demand (depending on oil intensity in the economy and on economic growth of major consuming nations);
- global supply of oil, in Organisation of the Petroleum Exporting Countries (OPEC) and non OPEC countries, which is itself linked to the market price (higher prices encourage exploration and exploitation of more expensive resources); investments in the development of new production capacities;
- evolution in the proven and ultimate reserves, and estimated time for peak oil when demand will outbalance the supply;
- production costs for conventional and unconventional oil;
- the geopolitical context (political tensions, e.g. Kuwait invasion in 1990, regional tensions, etc);
- short term technical situations in the exploitation of oil fields (e.g. temporary shortage of equipment in Alaska, hurricane season in Gulf of Mexico, etc).

A number of international institutions, organisations or analyst groups, regularly update projections of long term oil prices. For example:

- International Energy Agency (publication: World Energy Outlook),
- European Commission (publication: European Energy and Transport – Trends to 2030),
- Organisation of the Petroleum Exporting Countries (publication: Oil Outlook to 2025),
- US Department of Energy, Energy Information Administration (publication: Annual Energy Outlook 2006),

- World Bank,
- Major Utilities (EDF, etc).

The most recent projections might show some variations on the actual values from one institution to another but there is a consensus agreement over the general evolution of the oil price:

Phase I: oil price declines in the short term:

The average world oil price declines slowly from the current level (60-70 USD/bbl) to a minimum value in 2015, as new supplies enter the market, as well as substantial development of unconventional production.

Phase II: price rises through 2030:

The increase of the world oil price from 2015 reflects the rising costs for the development and production of non-OPEC oil resources with the approaching forecast peak oil, timed between 2020 to 2030 depending on scenarios.

Prospect for oil price remains extremely uncertain. It is interesting to note that in all available projections the differences between high and low scenarios have increased significantly compared to past year projections. This is a testimony to the growing uncertainties.

3.1.1.2 Oil price projections considered for the study

In this Study it will be used the most recent oil price forecast produced by the Energy Information Administration (Annual Energy Outlook 2006 report¹), updated to reflect 2006 prices.

There is considerable uncertainty associated with the price projections, related to world economic growth, world oil demand, OPEC's long-term oil production policies, and international political stability and proximity to peak oil.

Considering this uncertainty and the direct impact of fuel cost hypothesis to the profitability of an interconnection between Egypt, Ethiopia and Sudan, the Consultant suggests to consider the three scenarios defined in the Annual Energy Outlook 2006 (AEO2006) report:

- AEO2006 reference scenario:

In this scenario, the combined production capacity of members of the Organization of the Petroleum Exporting Countries (OPEC) does not increase as much as previously projected, and consequently world oil supplies are assumed to remain tight. The United States and emerging Asia—notably, China—are expected to lead the increase in demand for world oil supplies, keeping pressure on prices through to 2030. The reference case predicts that world oil prices will slowly fall to approximately 50 USD₂₀₀₆ per barrel by 2010 before steadily rising through to 2030, reaching a price of 59.8 USD₂₀₀₆ per barrel by the end of the study period.

The high and low price cases reflect different assumptions about the size of the conventional world oil resource, and they project different market shares for OPEC and non-OPEC oil production.

- AEO2006 high price scenario:

¹ Energy Information Administration, Annual Energy Outlook 2006, (www.eia.doe.gov/oiaf/aeo/index.html), (December 2006)

The high price case assumes that the world conventional crude oil resource base is 15% smaller than the USGS mean oil resource estimate. In the high price case, world oil production reaches 102 million barrels per day in 2030, with OPEC contributing 31% of total world oil production. World oil prices increase to approximately 80 USD₂₀₀₆ per barrel in 2015 and reach 100 USD₂₀₀₆ per barrel in 2030.

- AEO2006 low price scenario:

The low price case assumes that the conventional worldwide oil resource base is 15% larger than the US Geological Survey mean estimate. In the low price case, world oil production reaches 128 million barrels per day in 2030, with OPEC contributing 40% of total world oil production. World oil prices, in terms of the average price of imported low-sulphur crude oil to U.S. refiners, drop to 35.4 USD₂₀₀₆ per barrel in 2015 and remain relatively stable thereafter.

The following Table and Figures (**Table 3.1.1-1 - Crude Oil world price projections** and **Figure 1.3-3 - World Oil Price Projections**) present the reference, the high and the low world oil price projections (in 2006 USD) over the period 2006 to 2030 which will be used in the Study.

Unit : 2006 USD/bbl

Scenario	2006	2007	2008	2009	2010	2015	2020	2025	2030
High	62.0	62.2	62.8	64.1	65.7	80.0	89.2	94.7	100.4
Reference	62.0	58.3	54.9	52.6	49.6	50.1	53.2	56.7	59.8
Low	62.0	56.5	51.3	47.1	42.3	35.4	35.7	36.1	35.4

Table 3.1.1-1 - Crude Oil world price projections

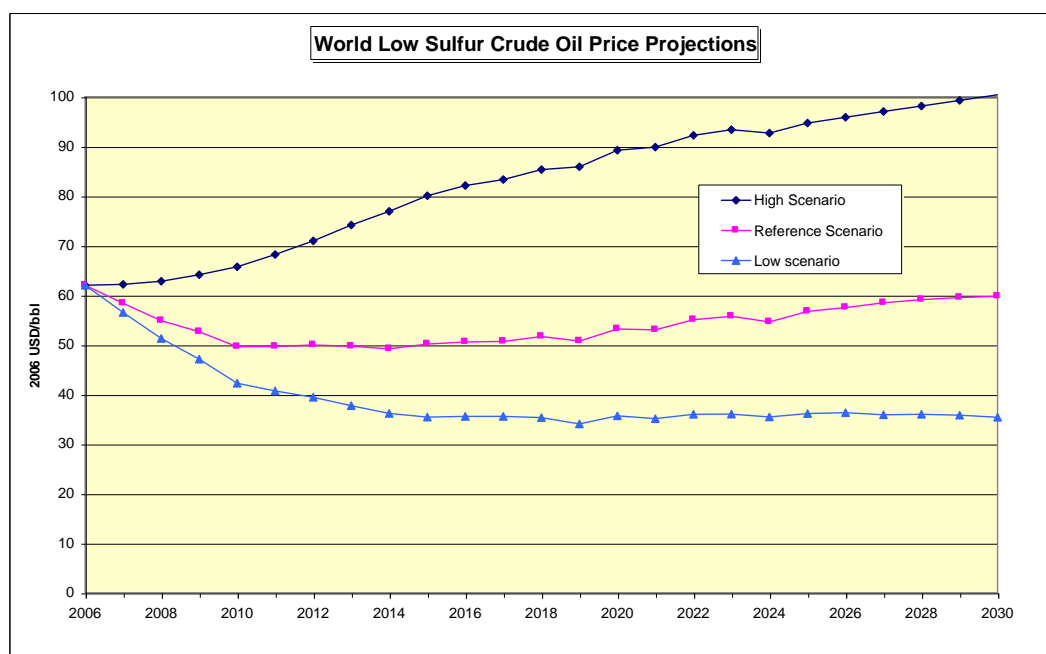

Figure 1.3-3 - World Oil Price Projections

3.1.2 NATURAL GAS PRICE

3.1.2.1 Overview

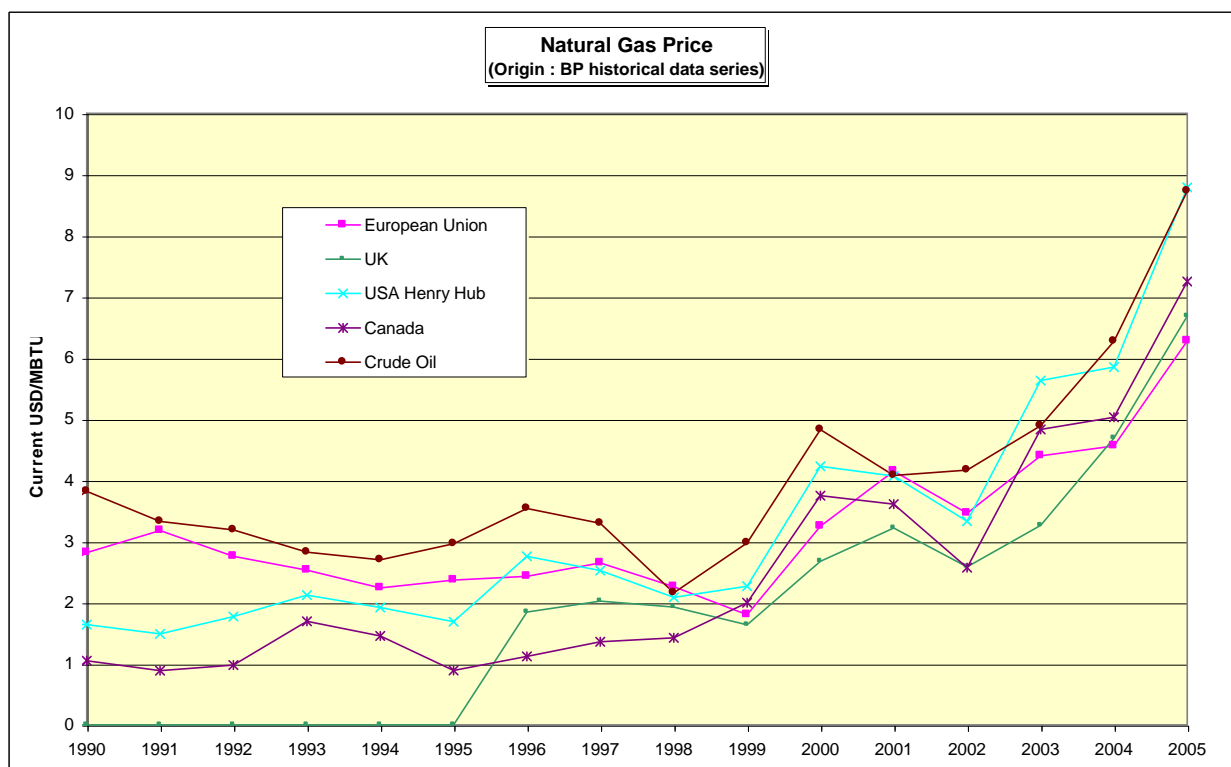

Figure 1.3-4 - Historical price of Natural Gas

While the oil market is fairly integrated at a global level, this is not the case for gas and coal which still show a strong regional basis. The main reason for these regional differentiations is the high transportation cost of gas and coal, relative to their production cost. Although the development of LNG transport facilities will introduce some degree of trade-off between regional gas markets the price differentials are not expected to fully disappear over the next 30 years (see: European Energy and Transport – Scenarios on oil and gas price – 2006 – European Commission).

Higher world oil prices are expected to result in a shift away from petroleum consumption and toward natural gas consumption in all sectors of the international energy market. In addition, some NG contract prices are tied directly to crude oil prices, putting further upward pressure on NG prices. Finally, higher oil prices are expected to promote increases in gas based production, which in turn would lead to more price pressure on world natural gas supplies.

Accordingly, in all the previously mentioned studies, natural gas prices are assumed broadly to follow the trend in oil prices, because of the continuing widespread use of oil-price indexation in long-term gas contracts and because of inter-fuel competition.

The following figure describes the major natural gas trade movement across the world. North American and Europe remain the largest markets in 2030 according to the World Energy Outlook 2006. The natural market for the Egyptian natural gas export is mainly European and Middle East (Jordan, Syria, Lebanon, etc).

The market price reflects the fact that the Natural Gas could, either be burned in the power plant or sold to the market. Accordingly, the market price is the best estimation of the real value of the Natural Gas to Egyptian economy.

Europe and Africa is the main regional market for Egyptian Natural Gas from Egypt. Accordingly, the Consultant proposes to considered in the Study the recent projections made for the European and African Market by the European Commission experts (ref PRIMES 2006):

Unit : USD₂₀₀₆/MBTU

Scenario	2006	2010	2015	2020	2025	2030
High	6.5	6.4	7.4	7.9	9.0	10.5
Reference	6.5	6.4	6.4	7.0	8.1	8.4
Low	6.5	4.8	4.9	5.0	5.1	6.6

Table 3.1.2-1 - Natural Gas price projection

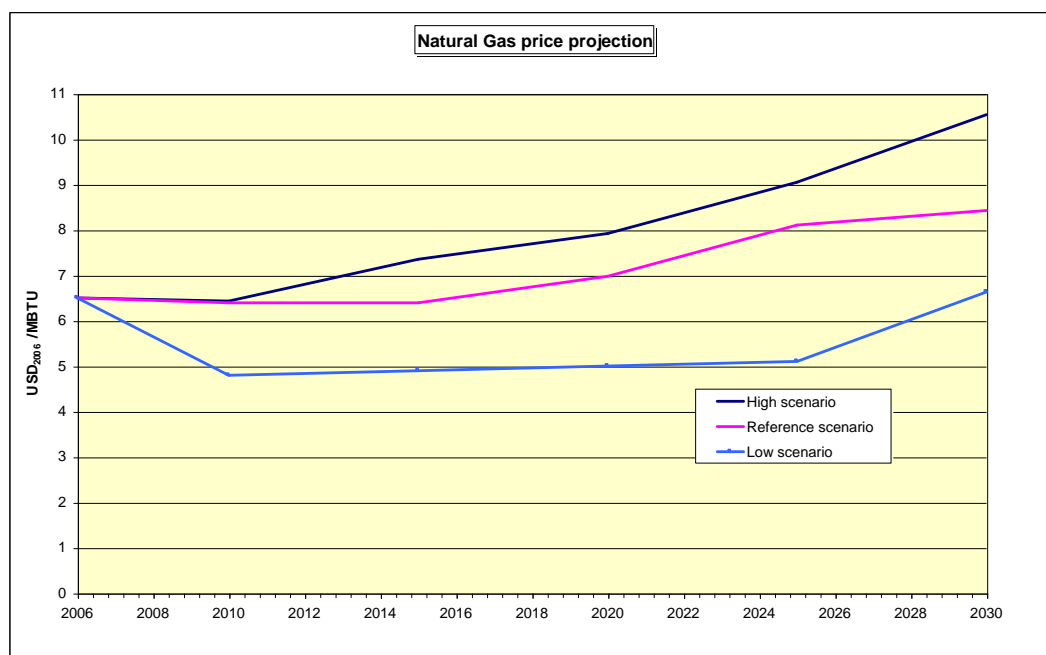

Figure 1.3-6 - Natural Gas price projections for the European and African Market

3.1.3 COAL PRICE

3.1.3.1 Overview

World proven coal reserves are enormous. Compared with oil and natural gas, they are widely dispersed. Over 40% of the world's 907 billion tonnes of coal reserves – equal to almost 200 years of production at current rates – is located in OECD countries.

Despite the rapid escalation of coal prices in recent years, many market fundamentals remain unchanged, so that prices are likely to moderate in the long term. There are many existing and potential suppliers, the market is still highly competitive and coal prices remain low relative to the prices of other primary energy commodities.

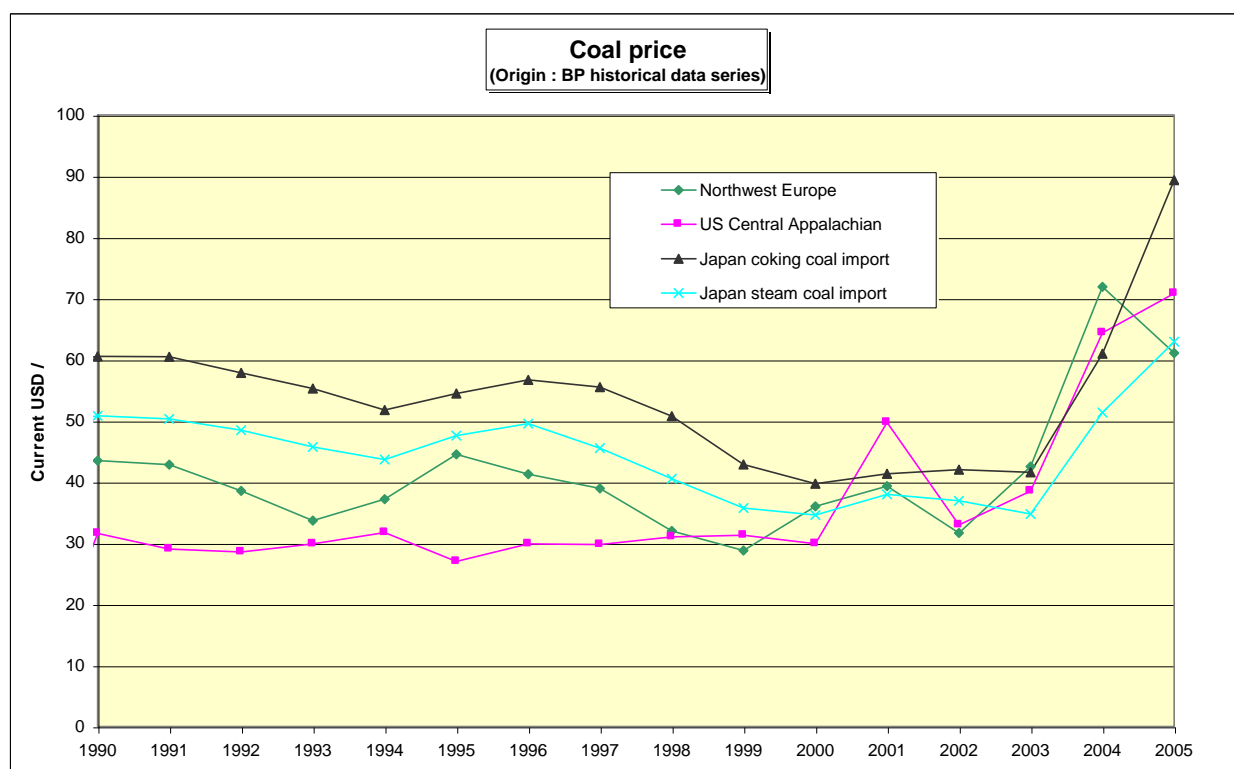

Figure 1.3-7 - Historical price of coal

3.1.3.2 Coal price projections considered in the study

Generally speaking, coal prices are assumed to change proportionally less than oil and gas over time, but follow the direction of oil and gas prices.

Within the frame work of the present Study, coal price projections will be used mainly for the TPP supply candidates in Sudan. Accordingly, as the profitability of the interconnection will result from the competitiveness of HPP in Ethiopia or Sudan, with respect to gas fired CCGT in Egypt, the Consultant find appropriate to consider only one scenario of coal price, with a constant value all

over the period of study of 63 USD2006/t, in line with the PB Power study 2006 for Sudan Generation Expansion Plan.

3.1.4 PRICE OF OIL DERIVATIVES

The ratio of oil derivatives price to crude oil price have been studied from 1999 to 2006. The resulting average values are:

- HFO price = 0.68 x crude oil price
- Diesel oil price = 1.25 x crude oil price
- Gas oil price = 1.5 x crude oil price

The resulting fuel price projections are given in Appendix Vol 5.

3.1.5 NET CALORIFIC VALUE

The net calorific value is the quantity of heat liberated by the complete combustion of a unit of fuel when the vapour produced is assumed to remain as a vapour and the heat is not recovered.

The net calorific value is a key parameter to determine the specific cost of fuel. The exact value may differ according to the exact type of fuel. The following table presents default values used by Eurostat and the values used in Egypt, Ethiopian and Sudan previous studies:

Origin	HFO	Gasoil	Diesel	Crude Oil	Coal
Eurostat	40.0 GJ/t	42.3 GJ/t	42.3 GJ/t		
Egyptian GEP 2006	39.68 MBtu/t (=41.9 GJ/t)				
Ethiopian GEP 2003	42.6 GJ/t		44.7 GJ/t		
Sudanese GEP 2006	40.4 GJ/t	42.8 GJ/t	42.1 GJ/t	42.6 GJ/t	

Table 3.1.5-1 - Typical net calorific values

NB:

* origin = World Energy Council <http://www.worldenergy.org>

It can be noted that Eurostat values are a few percents lower than the default values used by IAE.

The previous Table shows small differences of NCV according to the origin of the data. These differences are second order magnitude to the difference of fuel price projections for the same fuel. Accordingly, the Consultant proposes to use the same net calorific values for the same type of fuel in the different countries. According to the findings of Module 3 Vol 2, 3 and 4:

- HFO will be mainly used in Egypt for existing or committed TPP. The Consultant recommend to use Eurostat NCV of 40.0 GJ/t.
- Gasoil will be used in Sudan for future peak load Gas Turbine. The Consultant recommend the value used in Sudanese LTPSPS 2006: 42.8 GJ/t, which is close to Eurostat value.
- Diesel will be used in Ethiopia and Sudan. The Consultant recommend to use the Eurostat value, which is close to the value used in Sudanese LTPSPS 2006.
- Crude oil will be used only for LSD in Sudan. The Consultant recommend to use the value used in Sudanese LTPSPS 2006 which is close to typical values.
- Coal will be used only for new TPP Sudan. The NCV depends on the type of coal. However, the Consultant recommends to use the classic value of 26 GJ/t consistent with the coal price projection.

The following Table presents the values used for the present Study:

HFO	Gasoil	Diesel	Crude Oil	Coal
40.0 GJ/t	42.8 GJ/t	42.3 GJ/t	42.6 GJ/t	26 GJ/t

Table 3.1.5-2 - Net calorific values used in the study

3.1.6 ENERGY UNITS AND CONVERSION FACTOR

A number of various units are used to express energy, heat rate and net calorific value. A table of conversion factor is given in the appendix of Module 3 Vol 5.

4. OPTIONS FOR THE INTERCONNECTED SYSTEM

4.1 GENERATION CANDIDATES FOR THE INTERCONNECTED SYSTEM

The generation candidates to be considered in the evolution of the interconnected power systems are the same as for the separated power systems (see relevant chapters in Vol 2-3-4 of M3 report).

The Least Cost Generation Expansion Plan to be realised in Module 6 will provide the commissioning schedule of the most economical plants with and without the interconnection.

4.2 INTERCONNECTION OPTIONS FOR THE INTERCONNECTED SYSTEM

The analysis of the interconnection options is discussed along the following items:

- Identification of the interconnection alternatives.
- Identification of the interconnection points and the possible line routes.
- Identification of typical nominal costs (investment cost per km of line, converter station cost, etc).

This preliminary analysis is performed as an exercise to underline the key points of an interconnection between the three countries:

- The technology used: AC or DC
- The amount of power exchange

and to illustrate the impact of these choices on the transmission cost and consequently on the interconnection profitability.

The selected interconnection alternatives have not the same characteristics; they cannot transmit the same power, in the same N-1 conditions.

4.2.1 IDENTIFICATION OF THE INTERCONNECTION VIEWS

4.2.1.1 Presentation

Due to the long distance separating Ethiopia from Egypt, only a DC link would allow a huge power transfer between the two systems. But with the presence of the Sudanese System, that allows to control the voltage along the interconnection path, AC alternatives could also be competitive solutions to interconnect the three systems and transmit consequent power.

So, two AC alternatives and two DC alternatives will be investigated. They are described hereafter.

The interconnection line being mainly erected in Sudan and Egypt, it is proposed to select the 500 kV level for the AC alternatives that is the highest voltage level used in these two countries. For the DC alternative, the highest voltages normally used are the 500 or the 600 kV.

View A1:

One 500 kV AC single circuit line between Ethiopia and Sudan and one 500 kV AC single circuit line between Sudan and Egypt. 600 MW transit capacity.

View A2:

One 500 kV AC double circuit line between Ethiopia and Sudan and one 500 kV AC double circuit line between Sudan and Egypt. 1 000 MW transit capacity.

View A3:

One DC link with two poles, +/- 500 kV (or +/- 600 kV), between Ethiopia and Egypt with one 400 kV AC/DC substation in Ethiopia and one DC/AC 500 kV substation in Egypt. 1 200 MW transit capacity.

As a variant, a taping DC/AC 500 kV substation, connected in Sudan has been studied.

4.2.1.2 Main characteristics of the views

View A1:

This interconnection does not guarantee the power exchange between the two systems in case of interconnection link tripping. So, the power transfer should be limited to avoid activation of the under frequency load shedding scheme in the receiving country, Egypt, and a frequency overshoot in exporting countries, Ethiopia and Sudan when interconnection tripping.

The maximum power exchange could be limited to 600 MW. This value would be acceptable by the Egyptian system because it corresponds to the maximum size of the units in Egypt.

Moreover, to control the voltage profile along the line and to facilitate the energizing of the line, an intermediate switching substation should have to be installed in the middle of the line Sudan-Egypt.

If Egypt imports 600 MW power coming from Ethiopia to High Dam, the tripping of one of the two 500 kV circuits between High Dam and Nag Hamadi could induce overload on the remaining 500 kV circuit. To overcome this problem, the interconnection line should have to be automatically tripped.

View A2:

With the second circuit, the power exchange is guaranteed in N-1 situation (tripping of one circuit). The power exchange could be increased up to 1 000 MW. A larger value could adversely affect the operation of the interconnected system.

So in the following steps of the project, the network study will allow to determine the maximum power exchange between the systems. This study will allow also determining the necessary reinforcement of the 500 kV network between High Dam and Cairo 500, due to the transfer of 1 000 MW power exchange in the Egyptian system.

As the alternative A1, to control the voltage profile along the line Sudan-Egypt and to facilitate the energizing of the line, an intermediate switching substation would be installed in the middle of the line between Sudan and Egypt.

View A3:

- A3a: The DC link is equipped with two poles, in case of one pole tripping (or blocking the half of the AC/DC converter) the second pole can transmit half of the initial power with a return path by ground. The power exchange can be increased up to 1 200 MW, the loss of power exchange following the tripping of one pole would be limited to 600 MW, that is acceptable for the Egyptian system.
- A3b: The DC link is equipped with DC/AC tapping station located at Khartoum. The 1 200 MW power exported from Ethiopia are shared as follows:
 - o 300 MW to Sudan
 - o 900 MW to Egypt

4.2.2 IDENTIFICATION OF THE INTERCONNECTION POINTS AND THE POSSIBLE LINE ROUTES

4.2.2.1 THE INTERCONNECTION VIEWS

- The following interconnection points could be used to interconnect the AC lines:

In Ethiopia: The interconnection points could be the Border HPP, close to the border with Sudan, or Mandaya HPP located on the Blue Nile River.

In Sudan: The interconnection point for the AC line coming from Ethiopia would be the future 500 kV substation Hasaheisa, located south of Khartoum on the Blue Nile River. The interconnection point for the AC line going to Egypt would be Merowe 500 kV substation.

Dal HPP, which installed capacity is about 400 MW, could be used as an intermediate substation to control the voltage profile on the AC link between Sudan and Egypt.

In the frame of this preliminary analysis, Dal HPP was not selected as an interconnection point for AC alternatives, only Merowe HPP was kept. During the network study, performed in Module M6, variants of alternatives A1 & A2 with Dal HPP interconnection point will be investigated.

In Egypt: The interconnection point would be High Dam 500 kV substation.

- The following interconnection points could be used to interconnect the DC link:

In Ethiopia: The interconnection point would be Mandaya HPP, which the expected installed capacity is between 2 400 and 2 800 MW, able to export 1 200 MW or more.

In Sudan: The interconnection point could be located at Markhiat 500 kV substation. This DC/AC substation could be used to supply Khartoum area.

In Egypt: The interconnection points would be Assiut 500 kV substation and Cairo 500 substation.

The choice of these two substations could avoid reinforcing the 500 kV network between High Dam and Cairo 500.

The network study will investigate this power transfer impact on this Egyptian system.

4.2.2.2 The possible line routes

4.2.2.2.1 Presentation

This preliminary line routing was performed with the Africa North East map (Editor Michelin), which the scale is 1/4 000 000 (1 cm = 40 km). The objective was to estimate the length of the AC and DC lines.

4.2.2.2.2 Line route of the AC view A1 & A2

The following figures describe the line route for each view:

Figure 4.2-1 - AC views A1 & A2: line route between High Dam and Merowe

Figure 4.2-2 - AC view A line route between Hasaheisa - Border HPP

The connected points are:

- High Dam in Egypt;
- Merowe and Hasaheisa in Sudan;
- Border HPP or Mandaya HPP in Ethiopia.

Line route between High Dam and Roseires:

This section between High Dam and Roseires is the same for alternatives A1 and A2.

Section in Egypt: the line follows the road between Aswan and Abu Simbel.

Section in Sudan, between Wadi Halfa and Merowe: the line follows the left bank of the Nile River from Wadi Halfa to Dongola.

The line cross the Nile River close to Dongola and follows the track between Dongola and Karima still Merowe HPP.

Section in Sudan between Hasaheisa and Roseires: the line follows the road on the left bank of the Blue Nile River from Hasaheisa, to Wad Medani, Sennar and Roseires.

View A1: line route between Roseires and Border HPP

Close to Roseires Dam, the line crosses the Nile River and follows the right bank of the lake still Border HPP.

View A2: line route between Roseires and Mandaya HPP

Close to Roseires Dam, the line follows the left bank of the lake still Bikori. Then the line follows the road between Bikori and the border Gizen. It goes directly to the Blue Nile River, crosses the river and follows the right bank still Mandaya HPP.

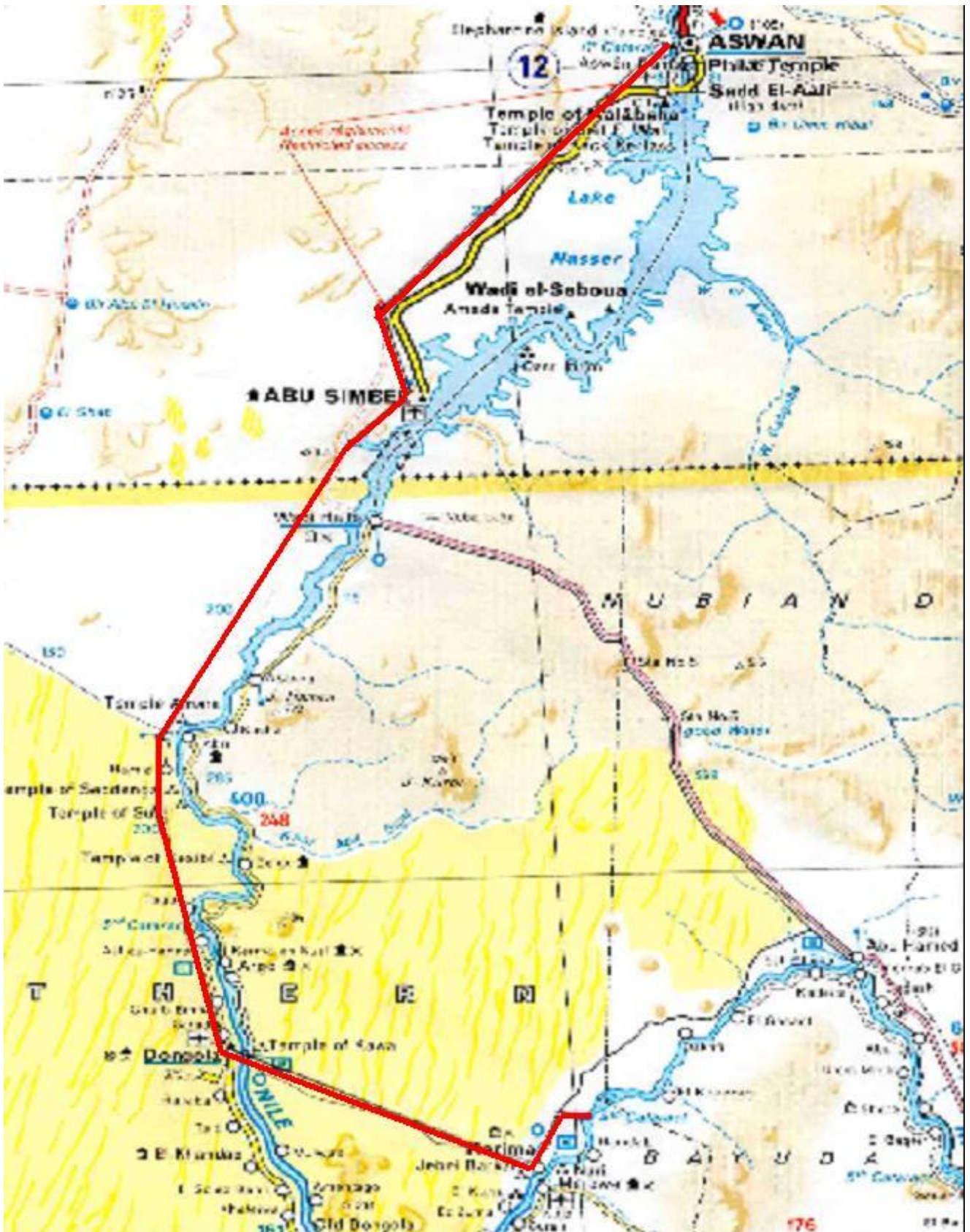

Figure 4.2-1 - AC views A1 & A2: line route between High Dam and Merowe

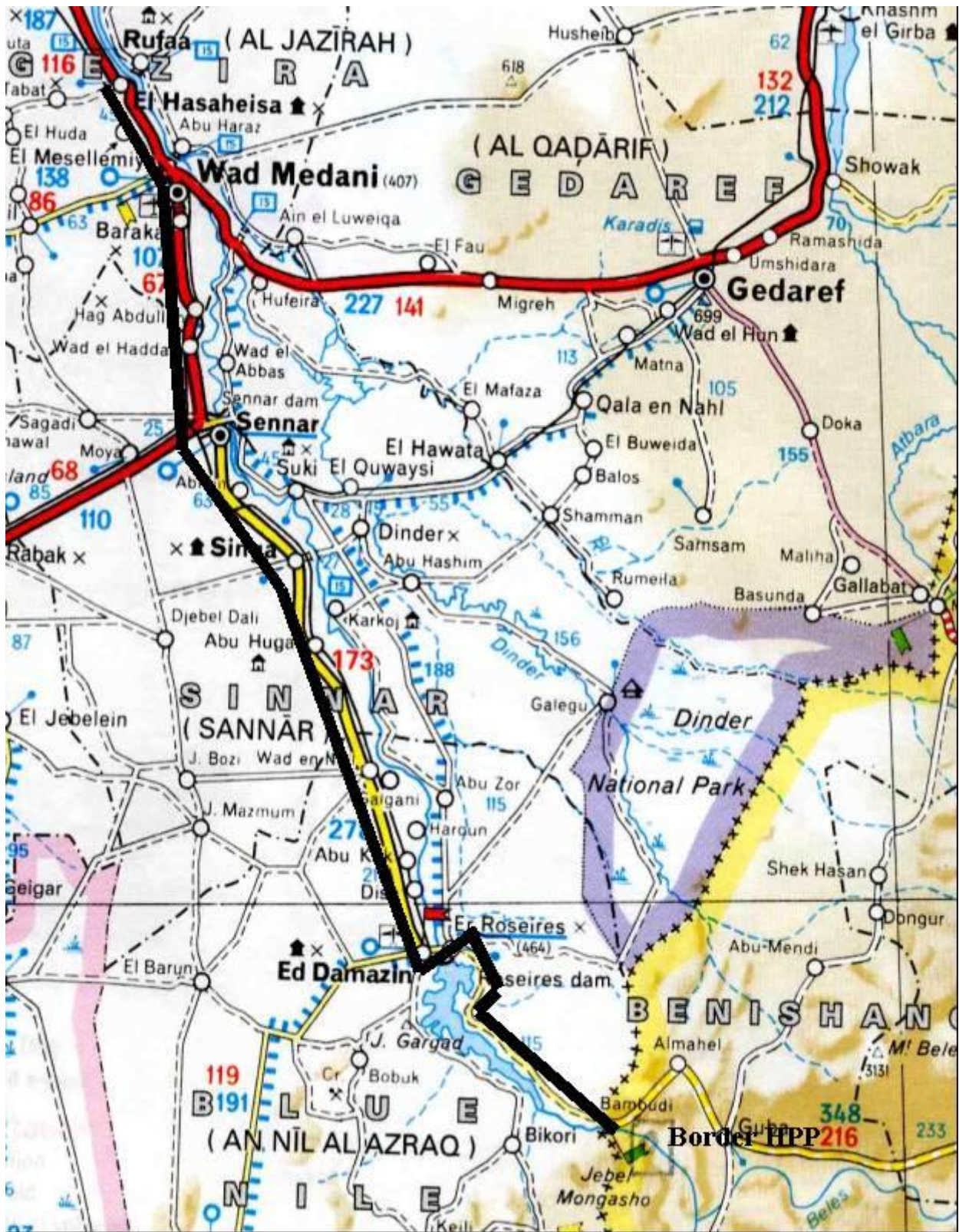

Figure 4.2-2 - AC view A line route between Hasaheisa - Border HPP

4.2.2.2.3 Line route of the DC views A3 (A3a and A3b)

The connecting points are Assiut in Egypt, Khartoum in Sudan (Markhiat) and Mandaya HPP in Ethiopia.

Section in Egypt: The line follows the road from Assiut to El Khârga and El Maks. It follows the track from El Maks to Bir Abu El Husein and El Shab still the border with Sudan.

Section in Sudan: The line goes directly from the border with Egypt to Dongola on the left side of the Nile River. It follows the road between Dongola and Khartoum, crosses the White Nile River up stream of Khartoum. It follows the road, on the left bank of the Blue Nile River, from Khartoum to Wad Medani, Sennar and Ed Damazin close to Roseires Dam. It follows the road along the left bank of Roseires Lake still the border with Ethiopia. It crosses the Blue Nile River and follows its right bank still Mandaya HPP.

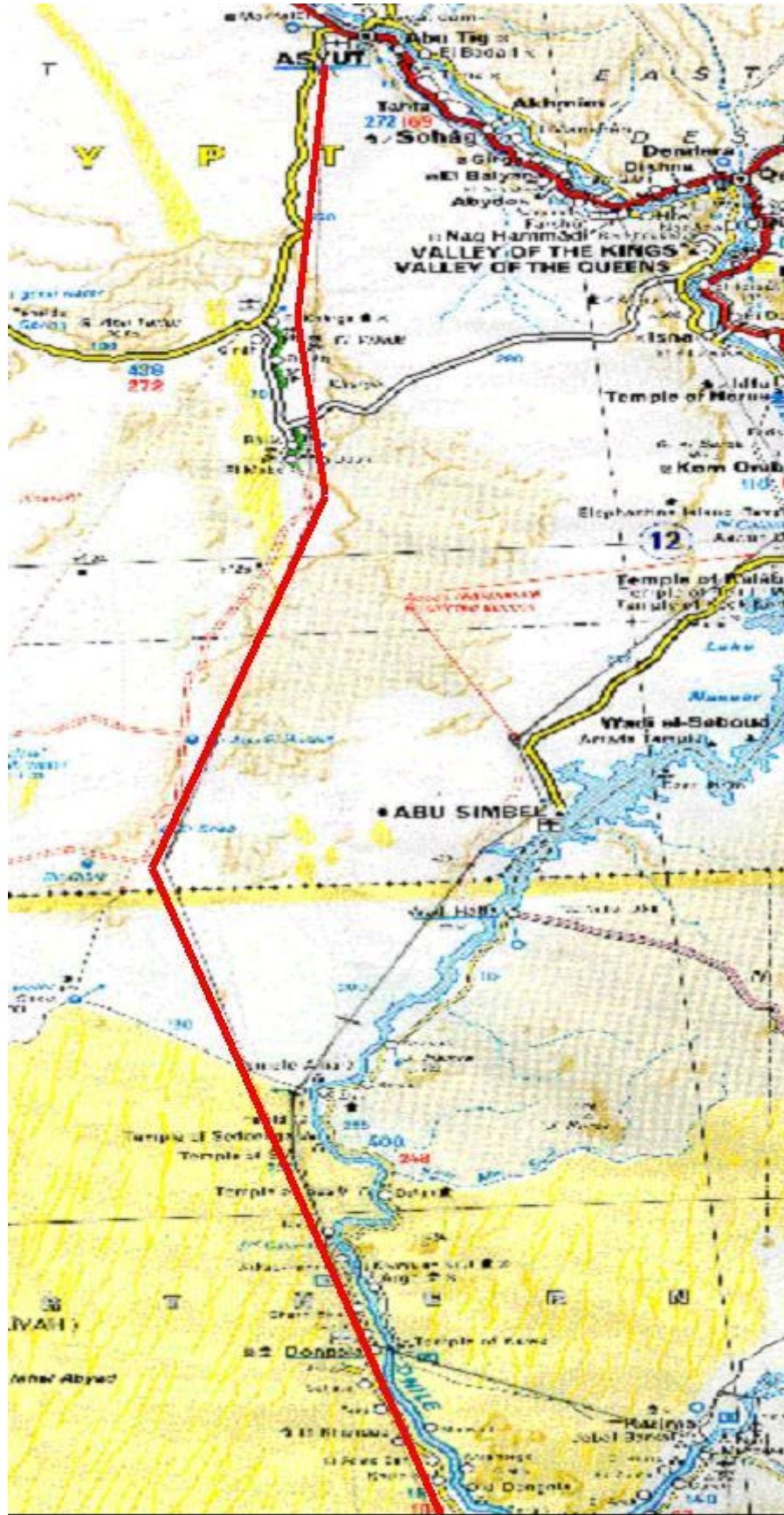

Figure 4.2-4 - DC view A3: line route between Assiut - Mandaya HPP (between Assiut and Dongola)

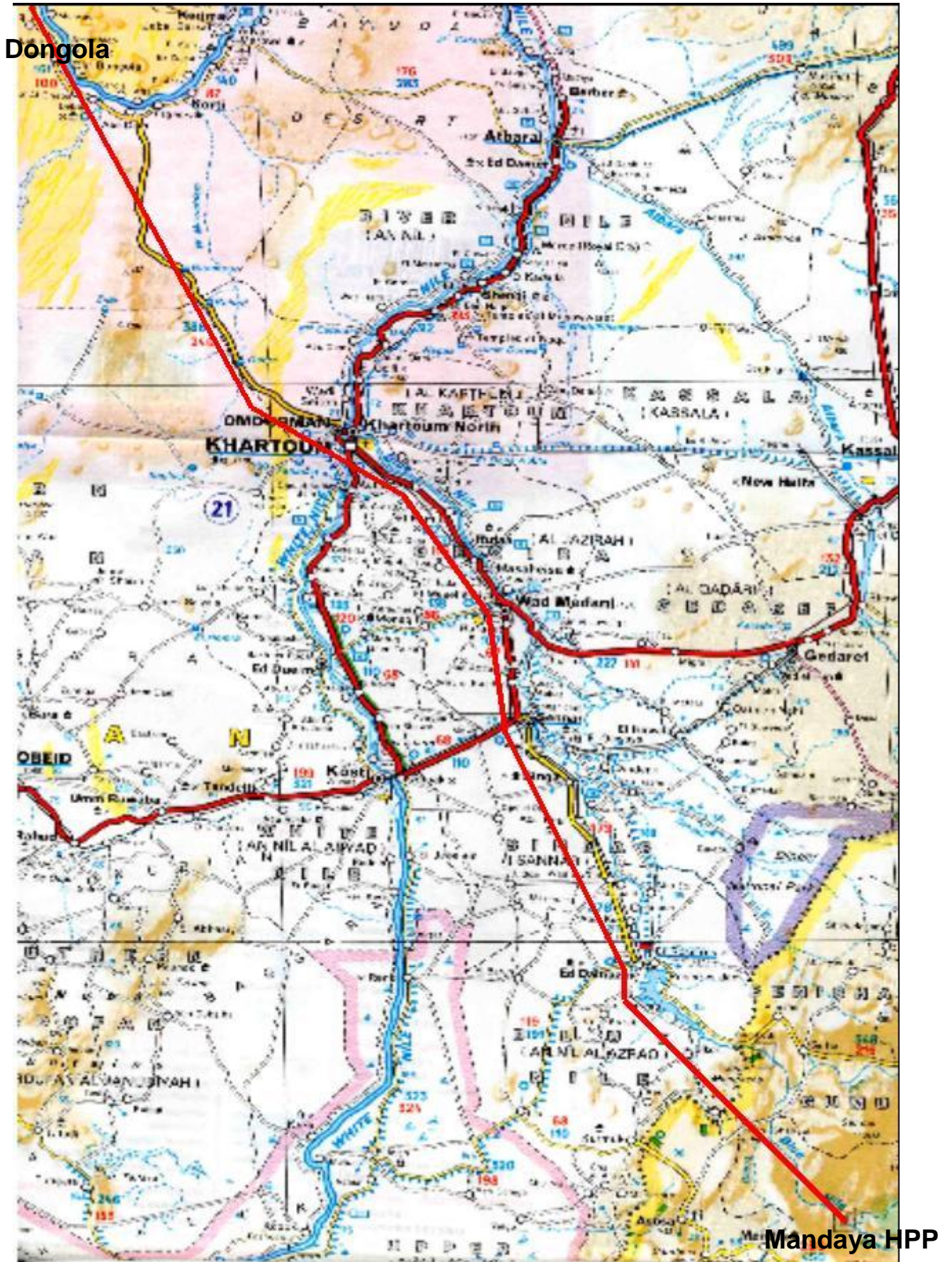

Figure 4.2-5 - DC view A3 - line route (between Dongola and Mandaya HPP)

4.2.3 IDENTIFICATION OF TYPICAL NOMINAL COSTS (INVESTMENT COST PER KM OF LINE, CONVERTER STATION COST, ETC)

4.2.3.1 General economic hypothesis

For the following calculation the general economic hypotheses are:

- Discount rate: 12% and 10% discount rate will be considered (see justification in 5.5.2).
- The power losses will be valued on the base of 40 USD/MWh, which is the average cost of the lowest cost HPP projects in Ethiopia and Sudan (see justification in 5.4.1).
- The load factor of the interconnection will be 5 000 hours per year (see justification in 5.2).

4.2.3.2 VIEW A1: 500 kV AC SINGLE CIRCUIT LINE

4.2.3.2.1 Description

(See **Figure 4.2-6 - View A1 - 500 kV AC single circuit line**)

The interconnection between Ethiopia, Sudan and Egypt includes:

- 500/400 kV substation located on Border HPP site, equipped with one 500/400 kV 660 MVA transformer. This transformation is composed by 3 single-phase units + 1 single-phase unit as a spare part.
- 500 kV AC single circuit line between Border HPP and Hasaheisa 500 kV substation. The length of the line is 440 km. The line is equipped at each end by one 180 MVAr reactor.
- 500 kV AC single circuit line between Merowe HPP and High Dam 500 kV substation. The length of the line is 880 km. To control the voltage profile along the line and to facilitate the energizing of the line, an intermediate switching substation is installed in the middle of the line, close to the border between Sudan and Egypt. The two sections of the line are equipped at each end by one 180 MVAr reactor. Moreover, one 100 MVAr reactor is connected on the 500 kV bus bar of the intermediate switching substation, to facilitate the energizing of the line.

Remark:

Maximum Transmissible Power between Merowe and High Dam: Due to the length of the 500 kV single-circuit line, the transmissible power is limited. This value can be roughly estimated with the formula:

$$P_{max} = (U1 * U2) / X$$

U1, U2: voltage at the two ends of AC line

$$P_{max} = 500^2 / (0.276 \times 880)$$

X: impedance of the line

$$P_{max} = 1\,029 \text{ MW}$$

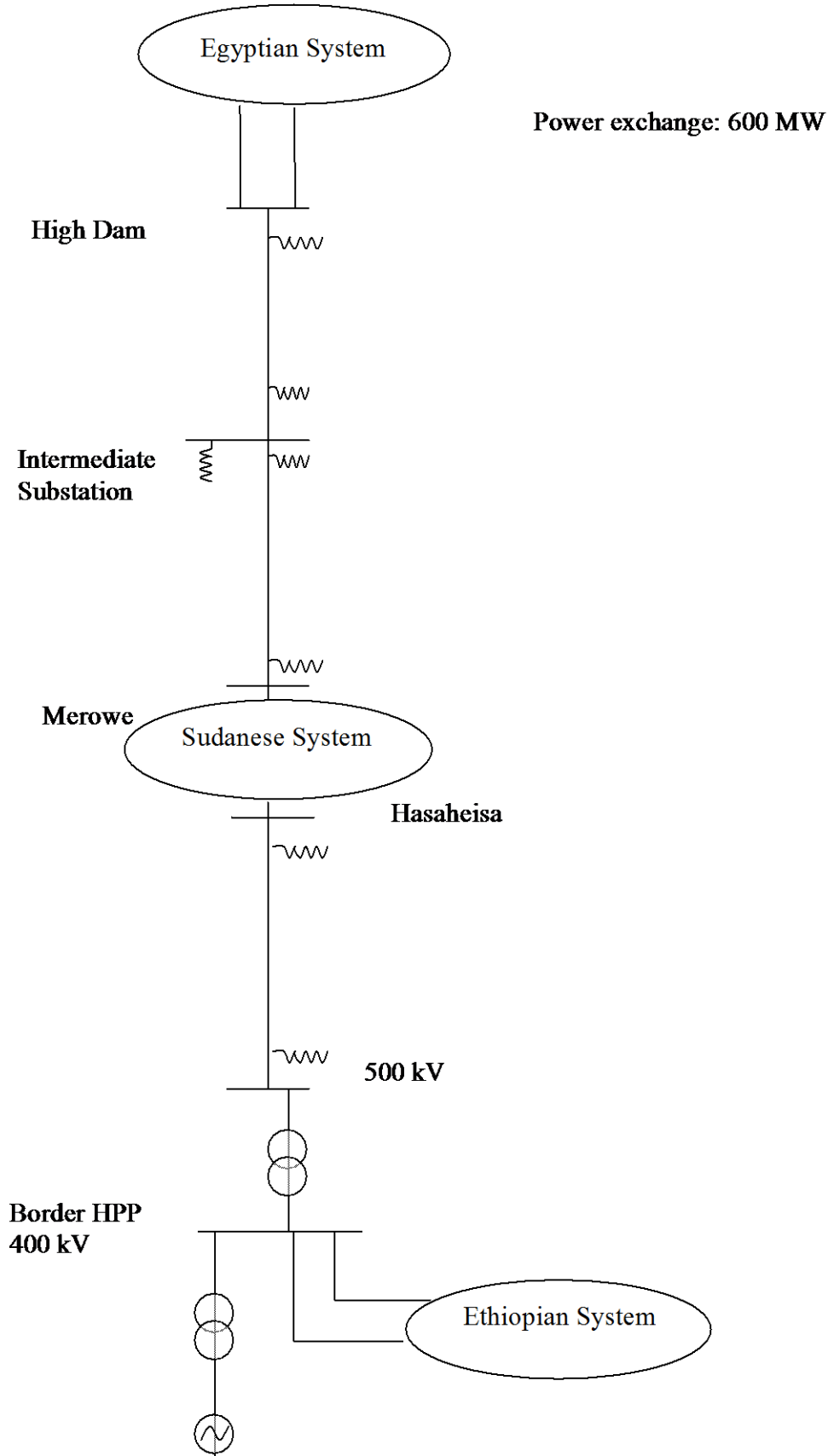

Figure 4.2-6 - View A1 - 500 kV AC single circuit line

4.2.3.2.2 Interconnection Cost

The cost is calculated with the unit costs displayed on Tables below. This cost includes the Interest During Construction.

(see: **Table 4.2.3-1 - View A1: 500 kV AC single circuit line – investment costs**)

From this interconnection cost, the anticipation cost or the annuity cost (A) can be calculated:

$$A = (i \times I_0) / (1 - 1/(1+i)^T)$$

$$A_{12} = 0.1204 \times I_0$$

$$A_{10} = 0.1009 \times I_0$$

To determine the total transmission cost, maintenance and operation costs and the cost of losses must be added all along the interconnection operation (one year for this calculation). The details of the calculation are displayed on the following tables:

- **Table 4.2.3-2 - View A1: 500 kV AC single circuit line - cost of losses**
- **Table 4.2.3-3 - View A1: 500 kV AC single circuit line - O&M costs.**

The hypotheses are:

- Economic life duration: T = 50 years
- Discount rates: i = 12 % and i = 10%
- Operation and maintenance cost: 1% of capital cost for the line, 2% of capital cost for the substation equipment.
- Power exchange: 600 MW from Ethiopia to Egypt.
- Duration of the power exchange: 5 000 hr/year
- Annual energy delivered = 600 x 5 000 = 3 000 000 MWh
- Cost of losses: 40 \$/MWh

The Annual Transmission cost is calculated as follows:

$$AT = \sum (\text{annuity cost} + \text{annual cost of losses} + \text{annual operation and maintenance cost})$$

From this total Annual Transmission cost, the transmission cost per MWh (Ct) is deduced as follows:

$$Ct = AT / \text{annual energy delivered}$$

The results of the calculations are displayed in the following Table.

Module M3: Energy Sector Profile & Projections

Vol 5

Costs (k\$)	i= 12%	i= 10%
Total investment cost (i0)	465 215	451 205
Annuity cost (A)	56 020	45 527
Annual Transmission cost (AT)	73 213	62 720
Transmission cost \$/MWh: Ct	24.4	20.9

Equipment	Description	i=12 %		i=10 %		Capital Cost (k\$)
		Unit Cost (k\$)	Net Cost (k\$)	Unit Cost (k\$)	Net Cost (k\$)	
Hasaheisa – Border HPP 500 kV line	440 km	262	115 280	253	111 320	92 400
500 kV line Bay	2	2 464	4 928	2 420	4 840	4 400
500 kV shunt reactor	2 x 180 MVar	67	24 120	66	23 760	21 600
<u>500/400 kV Border HPP substation</u>						
500/400 kV transformer	4 x 220 MVA	4 546	18 184	4 424	17 696	15 320
500 kV transformer bay	1	2 173	2 173	2 134	2 134	1 940
400 kV transformer bay	1	1 290	1 290	1 265	1 265	1 150
500 kV line Merowe – High dam	880 km	262	230 560	253	222 640	184 800
500 kV line Bay at Merowe	1	2 464	2 464	2 420	2 420	2 200
500 kV line Bay at High Dam	1	3 248	3 248	3 190	3 190	2 900
500 kV shunt reactor	4 x 180 MVar	67	48 240	66	47 520	43 200
<u>500 kV Intermediate substation</u>						
New substation equipment	1	2000	2000	1900	1900	1 800
500 kV line Bay	2	2 464	4 928	2 420	4 840	4 400
500 kV bus shunt reactor	1 x 100 MVar	67	6 700	66	6 600	6 000
500 kV shunt reactor bay	1	1 100	1 100	1 080	1 080	980
Total Investment Cost			465 215		451 205	383 090

Table 4.2.3-1 - View A1: 500 kV AC single circuit line – investment costs

Transmission Losses	R (Ω /km)	L(km)	R(Ω)	I kA	Power Losses (MW)	Duration (h)	Losses (MWh)	Cost of losses (k\$)
Hasaheisa - Border HPP line	0.028	440	12.32	0.69	17.74	5 000	88 704	3 548
Shunt Reactor 2 x 180 MVAR					1.44	8 760	12 614	505
Transformer 660 MVA			0.5	0.69	0.71	5 000	3 571	143
Iron losses of transformer					0.17	8 760	1 489	60
Merowe - High Dam line	0.028	880	24.64	0.69	35.19	5 000	175 967	7 039
Shunt Reactor 4 x 180 MVAR					2.88	8 760	25 229	1 009
Total losses					58.14		307 574	12 303

Table 4.2.3-2 - View A1: 500 kV AC single circuit line - cost of losses

Operation and maintenance costs	Capital cost (k\$)	Rate	Annual cost (k\$)
Hasaheisa - Border HPP line	92 400	0.01	924
Substation equipment	44 410	0.02	888
Merowe - High Dam line	184 800	0.01	1 848
Substation equipment	61 480	0.02	1 230
Total	383 090		4 890

Table 4.2.3-3 - View A1: 500 kV AC single circuit line - O&M costs

4.2.3.3 VIEW A2: 500 kV AC DOUBLE CIRCUIT LINE

4.2.3.3.1 Description

The interconnection between Ethiopia, Sudan and Egypt includes:

- 500/400 kV substation located on Mandaya HPP site, equipped with two 500/400 kV 555 MVA transformers. This transformation is composed by 2x3 single-phase units + 1 single-phase unit as a spare part.
- 500 kV AC double circuit line between Mandaya HPP and Hasaheisa 500 kV substation. The length of the line is 600 km. Each circuit of the line is equipped by two 250 MVAR reactors.
- 500 kV AC double circuit line between Merowe HPP and High Dam 500 kV substation. The length of the line is 880 km. To control the voltage profile along the line and to facilitate the energizing of the line, an intermediate switching substation is installed in the middle of the line, close to the border between Sudan and Egypt. Each circuit of the line is equipped by two 180 MVAR reactors. Moreover, one 100 MVAR reactor is connected on the 500 kV bus bar of the intermediate switching substation, to facilitate the energizing of the line.

The 1 000 MW imported from Ethiopia could induce constraints on the 500 kV Egyptian system between High Dam and Assiut in N-1 situation. (Tripping of one 500 kV circuit between High Dam and Assiut) To estimate the cost of the interconnection, a third 500 kV circuit between High Dam and Assiut has been added.

Remark:

Maximum Transmissible Power between Merowe and High Dam in N-1 situation:

Thanks to the intermediate substation, in N-1 situation, only one circuit between Merowe and Intermediate substation or Intermediate substation and High Dam is tripped. The impedance of the resulting link reaches 182 Ω , so the maximum transmissible power reaches 1 370 MW.

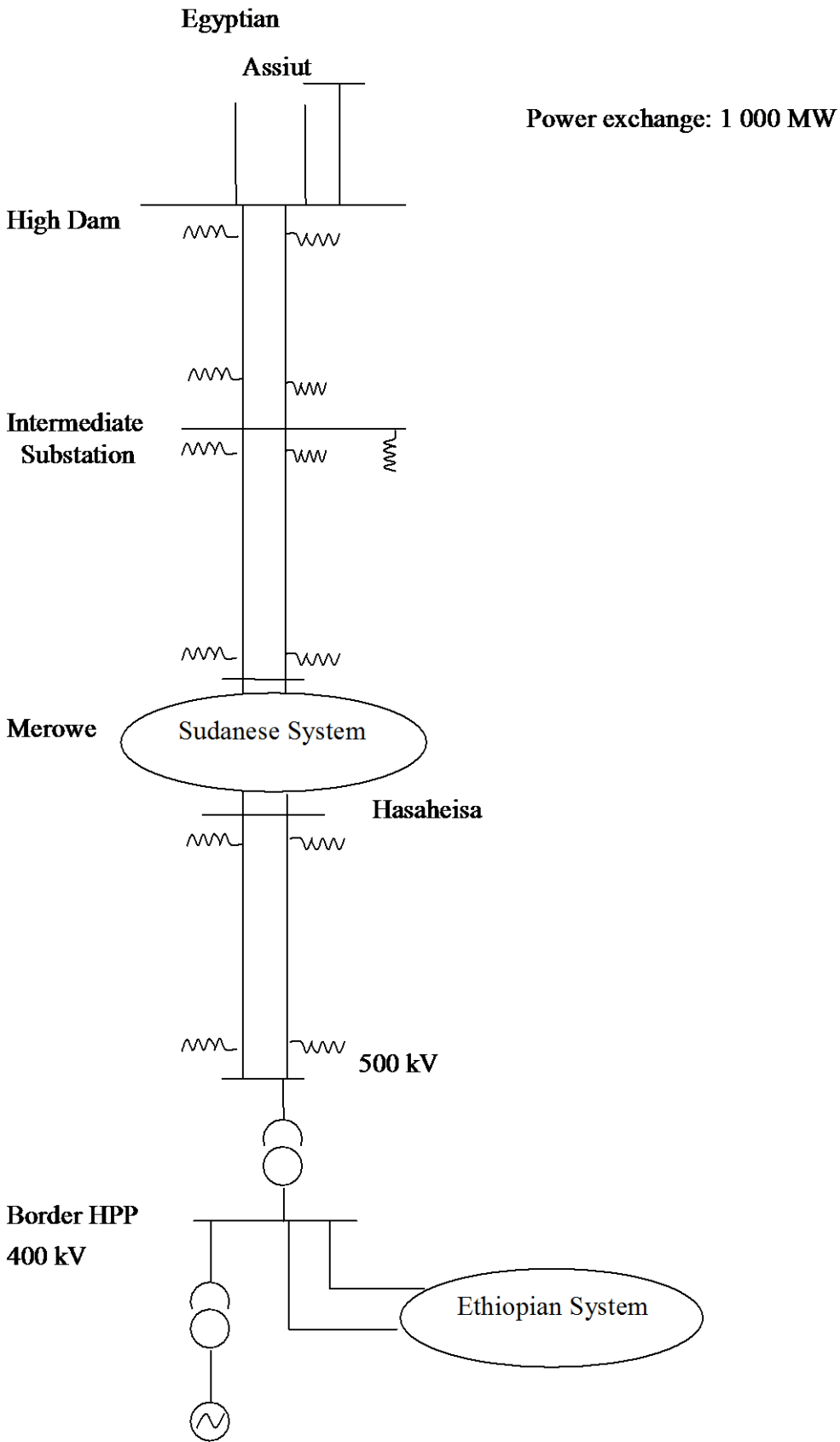

Figure 4.2-7- View A2 - 500 KV double circuit line

4.2.3.3.2 Interconnection cost

The cost is calculated with the unit costs displayed on the Tables 4.2.13 and 4.2.14. This cost includes the Interest During Construction.

(See details in **Table 4.2.3-4 - View A2: 500 kV AC double circuit line - investment cost**)

From this interconnection cost, the anticipation cost or the annuity cost (A) can be calculated:

$$A = (i \times I_0) / (1 - 1/(1+i)^T)$$

$$A_{12} = 0.1204 \times I_0$$

$$A_{10} = 0.1009 \times I_0$$

To determine the total transmission cost, maintenance and operation costs and the cost of losses must be added all along the interconnection operation. The details of the calculation are displayed on the following tables:

Table 4.2.3-4 - View A2: 500 kV AC double circuit line - investment costs

Table 4.2.3-6 - View A2: 500 kV AC double circuit line - O&M costs.

The hypotheses are:

- Economic life duration: T = 50 years
- Discount rates: i = 12 % and i = 10%
- Operation and maintenance cost: 1% of capital cost for the line, 2% of capital cost for the substation equipment.
- Power exchange: 1 000 MW from Ethiopia to Egypt.
- Duration of the power exchange: 5 000 hr/year
- Annual energy delivered = 1 000 x 5 000 = 5 000 000 MWh
- Cost of losses: 40 \$/MWh

The Annual Transmission cost is calculated as follows:

$$AT = \sum (\text{annuity cost} + \text{annual cost of losses} + \text{annual operation and maintenance cost})$$

From this total Annual Transmission cost, the transmission cost per MWh (Ct) is deduced as follows:

$$C_t = AT / \text{annual energy delivered}$$

The results of the calculations are displayed in the following table.

Module M3: Energy Sector Profile & Projections

Vol 5

Costs (k\$)	i= 12%	i= 10%
Total investment cost (i0)	1 023 175	991 253
Annuity cost (A)	123 190	100 017
Annual Transmission cost (AT)	152 966	129 793
Transmission cost \$/MWH: Ct	30.6	26

Equipment	Description	i=12%		i=10%		Capital Cost (k\$)
		Unit Cost (k\$)	Net Cost (k\$)	Unit Cost (k\$)	Net Cost (k\$)	
Hasaheisa – Mandaya HPP 500 kV double circuit line	600 km	445	267 000	429	257 400	214 200
500 kV line Bay	4	2 464	9 856	2 420	9 680	8 800
500 kV shunt reactor	4 x 250 MVAr	67	67 000	66	66 000	60 000
<u>500/400 kV Mandaya HPP substation</u>						
500/400 kV transformer	7 x 185 MVA	4 026	28 187	3 915	27 405	23 730
500 kV transformer bay	2	2 173	4 346	2 134	4 268	3 880
400 kV transformer bay	2	1 290	2 580	1 265	2 530	2 300
500 kV double circuit line Merowe – High dam	880 km	445	391 600	429	377 520	314 160
500 kV line Bay at Merowe	2	2 464	4 928	2 420	4 840	4 400
500 kV line Bay at High Dam	2	3 248	6 496	3 190	6 380	5 800
500 kV shunt reactor	8 x 180 MVAr	67	96 480	66	95 040	86 400
<u>500 kV Intermediate substation</u>						
New substation equipment	1	2 650	2 650	2 650	2 600	2 400
500 kV line Bay	4	2 464	9 856	2 420	9 680	8 800
500 kV bus shunt reactor	1 x 100 MVAr	67	6 700	66	6 600	6 000
500 kV shunt reactor bay	1	1 100	1 100	1 080	1080	980
500 kV single circuit line High Dam - Assiut	450 km	262	117 900	253	113 850	94 500
500 kV line Bay	2	3 248	6 496	3 190	6 380	5 800
Total Investment Cost			1 023 175		991 253	842 150

Table 4.2.3-4 - View A2: 500 kV AC double circuit line - investment costs

Module M3: Energy Sector Profile & Projections

Vol 5

Transmission Losses	R (Ω /km)	L (km)	R(Ω)	I (kA)	Power Losses (MW)	Duration (h)	Losses (MWh)	Cost of losses (k\$)
Hasaheisa - Mandaya HPP line	0.014	600	8.40	1.15	33.60	5 000	168 000	6 720
Shunt Reactor 4 x 250 MVAr					4.00	8 760	35 040	1 402
Transformer 555 MVA			0.25	1.15	0.99	5 000	4 959	198
Iron losses of transformer					0.34	8 760	2 978	119
Merowe - High Dam line	0.014	880	12.32	1.15	48.88	5 000	244 398	9 776
Shunt Reactor 8 x 180 MVAr					5.76	8 760	50 458	2 018
Total losses					93.57		505 833	20 233

Table 4.2.3-5 - View A2: 500 kV AC double line – cost of losses

Operation and maintenance costs	Capital cost (k\$)	Rate	Annual cost (k\$)
Hasaheisa - Mandaya HPP line	214 200	0.01	2 142
Substation equipment	98 210	0.02	1 964
Merowe - High Dam line	314 160	0.01	3 142
Substation equipment	114 780	0.02	2 296
Total			9 543

Table 4.2.3-6 - View A2: 500 kV AC double circuit line - O&M costs

4.2.3.4 VIEWS A3: +/- 500 kV DC DOUBLE POLE LINK

For these DC alternatives two options are examined:

- Alternative A3a: without DC/AC substation in Sudan, the DC line passes without stop through the Sudanese system.
- Alternative A3b: with DC/AC tapping substation in Sudan.

4.2.3.4.1 Description View A3a: without DC/AC substation in Sudan

The interconnection between Ethiopia and Egypt includes:

- AC/DC 1 200 MW converter located at Mandaya HPP substation.
- +/- 500 kV DC double pole line between Mandaya HPP and Assiut 500 kV substation. The length of the line is about 2 200 km.
- DC/AC 1 200 MW converter located at Assiut 500 kV substation.

The converters are equipped with thyristors (Line Commutated Converters LCC).

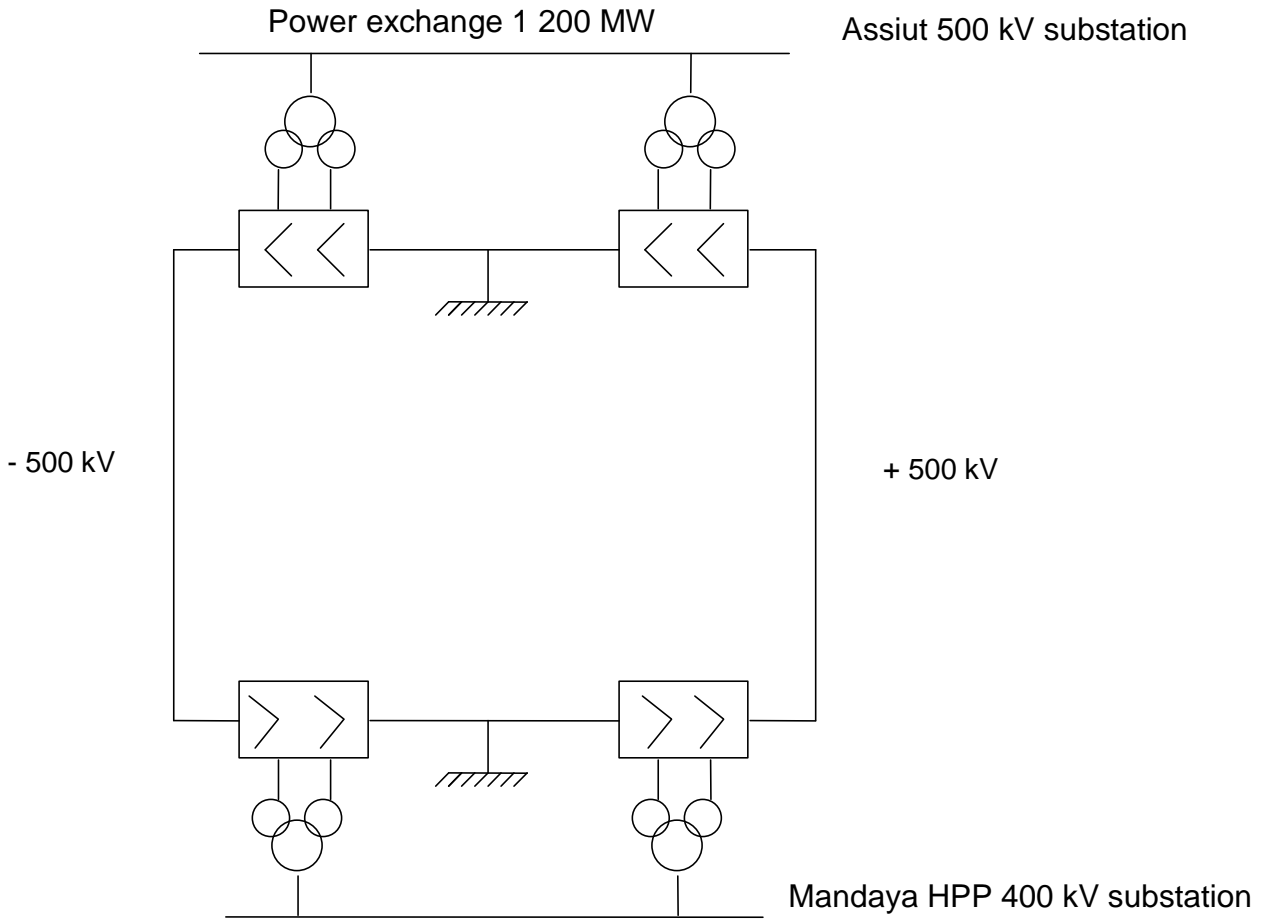

Figure 4.2-8 - View A3a: ± 500 kV DC line, without DC/AC substation in Sudan

4.2.3.4.2 Interconnection Cost of View A3a

The cost is calculated with the unit costs displayed on Tables below. This cost includes the Interest During Construction.

(see **Table 4.2.3-7 - View A3a: ± 500 kV DC double pole line – Investment costs**)

From this interconnection cost the anticipation cost or the annuity cost (A) can be calculated:

$$A = (i \times I01) / (1-1/(1+i)^{50}) + (i \times I02) / (1-1/(1+i)^{25})$$

$$A_{12} = 0.1204 \times I01 + 0.1275 \times I02$$

$$A_{10} = 0.1009 \times I01 + 0.1102 \times I02$$

I01: investment cost of the DC line

I02: investment cost of the converters

To determine the total transmission cost maintenance and operation costs and the cost of losses must be added all along the interconnection operation. The details of the calculation are displayed on the following tables:

Table 4.2.3-8 - View A3a: ± 500 kV double pole line – Cost of losses

Table 4.2.3-9 - View A3a: ± 500 kV double pole line – O&M costs

The hypotheses are:

- Economic life duration: 25 years for the converters and 50 years for the line.
- Operation and maintenance cost: 1% of capital cost for the line. 1.4% for the AC/DC converters.
- Power exchange: 1 200 MW from Ethiopia to Egypt.
- Duration of the power exchange: 5 000 h/year.
- Annual energy delivered = 1 200 x 5 000 = 6 000 000 MWh.
- Cost of the losses: 40 \$/MWh.

The Annual Transmission cost is calculated as follows:

$$AT = \sum (\text{annuity cost} + \text{annual cost of losses} + \text{annual operation and maintenance cost})$$

From this Total Annual Transmission cost, the transmission cost per MWh (Ct) is deduced as follows:

$$Ct = AT / \text{annual energy delivered}$$

Module M3: Energy Sector Profile & Projections

Vol 5

The results of the calculations are displayed in the following table.

Costs (k\$)	i= 12%	i= 10%
Total investment cost (I0+I02)	759 800	732 400
Annuity cost (A)	93 610	76 578
Annual Transmission cost (AT)	131 390	114 358
Transmission cost \$/MWh: Ct	21.9	19.1

Equipment	Description	i=12%		i=10%		Capital Cost (k\$)
		Unit Cost (k\$)	Net Cost (k\$)	Unit Cost (k\$)	Net Cost (k\$)	
Assiut – Mandaya HPP +/- 500 kV DC double pole line	2 200 km	209	459 800	202	444 400	369 600
AC/DC converters	2 x 1200	125	300 000	120	288 000	240 000
Total Cost			759 800		732 400	609 600

Table 4.2.3-7 - View A3a: ± 500 kV DC double pole line – Investment costs

Transmission Losses	R (Ω/km)	l (km)	R (Ω)	I (kA)	Losses (MW)	Duration (h)	e (MWh)	Cost of losses (k\$)
Assiut - Mandaya HPP line	0.016	2 200	35.20	1.20	101.38	5 000	506 880	20 275
AC/DC converter losses (5 000 h)					14.40	5 000	72 000	2 880
AC/DC converter losses (8 760 h)					14.40	8 760	126 144	5 046
Auxiliary losses					7.20	8 760	63 072	2 523
Total losses					137.38		768 096	30 724

Table 4.2.3-8 - View A3a: ± 500 kV double pole line – Cost of losses

Operation and maintenance costs	Investment cost (k\$)	Rate	Annual cost (k\$)
Assiut - Mandaya HPP line	369 600	0.01	3 696
AC/DC converters	240 000	0.014	3 360
Total			7 056

Table 4.2.3-9 - View A3a: ± 500 kV double pole line – O&M costs

4.2.3.4.3 Description Alternatives A3b: with DC/AC substation in Sudan

(See

Figure 4.2-9 - View A3b: \pm 500 kV DC line, with DC/AC substation in Sudan)

The interconnection between Ethiopia, Sudan and Egypt includes:

- AC/DC 1 200 MW converter located at Mandaya HPP substation in Ethiopia.
- \pm 500 kV DC double pole line between Mandaya HPP and Assiut 500 kV substation, with a stop in Markhiat 500 kV substation. The total length of the line is about 2 200 km.
- DC/AC 300 MW converter located at Markhiat 500 kV substation in Sudan.
- DC/AC 900 MW converter located at Assiut 500 kV substation in Egypt.

The converters are equipped with thyristors (Line Commutated Converters LCC).

Remark: The DC line between Khartoum and Assiut has the same characteristics (cross section $6 \times 280 \text{ mm}^2$) than the line in the A3a View. Indeed, if Khartoum did not participate at power exchange, 1 200 MW could be transmitted from Ethiopia to Egypt, without excessive losses and voltage drop, as View A3a. For this preliminary analysis, the DC line has not been optimised taking into account the transmitted power, the duration of the exchange and the cost of the losses.

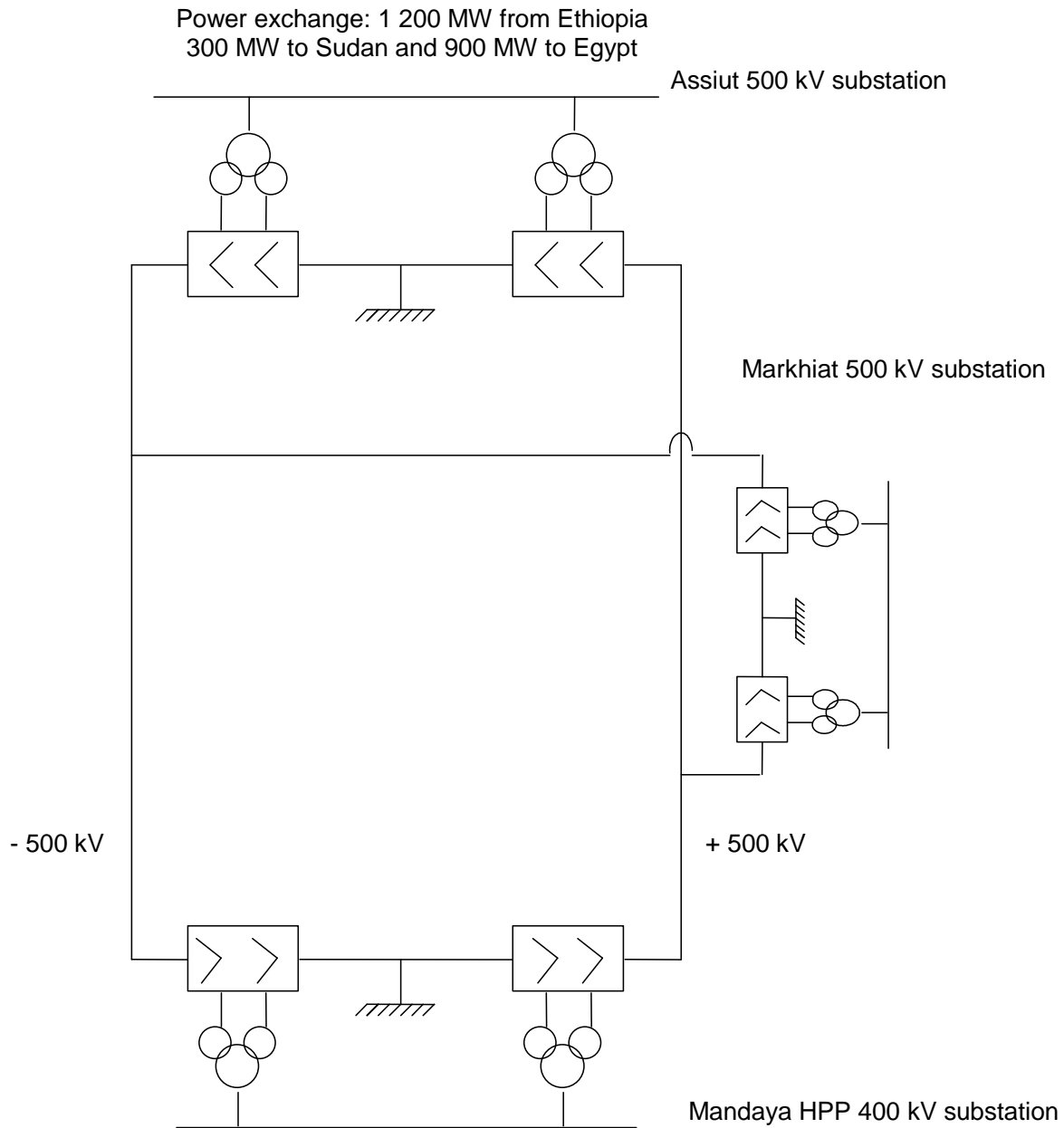

Figure 4.2-9 - View A3b: \pm 500 kV DC line, with DC/AC substation in Sudan

4.2.3.4.4 Interconnection cost of View A3b

The cost is calculated with the unit costs displayed on the Tables 4.2.13 and 4.2.14. This cost includes the Interest During Construction.

(See Table 4.2.3-13 - View A3b: \pm 500 kV DC double pole line – Investment costs)

Annuity cost:

From this investment cost (including IDC), the anticipation cost or the annuity cost (A) can be calculated:

$$A = (i \times I01) / (1 - 1/(1+i)^{50}) + (i \times I02) / (1 - 1/(1+i)^{25})$$

where

i = discount rate

I01: investment cost of the DC line (including IDC)

I02: investment cost of the converters (including IDC)

The resulting annuity costs for 12% and 10% discount rates are:

$$A_{12} = 0.1204 \times I01 + 0.1275 \times I02$$

$$A_{10} = 0.1009 \times I01 + 0.1102 \times I02$$

Total annual transmission cost:

To determine the total transmission cost, maintenance and operation costs, cost of losses must be added to the investment cost all along the interconnection operation. The details of the calculation are displayed on the following tables:

Table 4.2.3-14 - View A3b: ± 500 kV double pole line – Cost of losses

Table 4.2.3-15 - View A3b: ± 500 kV double pole line – O&M costs

The hypotheses are:

- Economic life duration: 25 years for the converters and 50 years for the line.
- Operation and maintenance cost: 1% of investment cost for the line. 1.4% for the AC/DC converters.
- Power exchange: 1 200 MW from Ethiopia, 300 MW to Sudan, and 900 MW to Egypt.
- Duration of the power exchange: 5 000 h/year.
- Annual energy exported from Ethiopia = 1 200 x 5 000 = 6 000 000 MWh.
- Annual energy delivered to Sudan = 300 x 5 000 = 1 500 000 MWh.
- Annual energy delivered to Egypt = 900 x 5 000 = 4 500 000 MWh.
- Cost of the losses: 40 \$/MWh

The Annual Transmission cost is calculated as follows:

$$AT = \sum (\text{annuity cost} + \text{annual cost of losses} + \text{annual operation and maintenance cost})$$

Transmission cost per MWh:

The calculation of the transmission cost per MWh is not as straightforward as for the previous options. Part of the line and of the substations is used to transmit power up to Sudan (1 200 MW) while another part is used to provide less power (900 MW) up to Egypt.

Accordingly, the transmission cost will be calculated in several steps:

- the Ethiopian substation and the line from Ethiopia to Sudan (Ct1, 1 200 MW),
- the substation in Sudan (Ct2, 300 MW),
- the line from Sudan to Egypt and the substation in Egypt (Ct3, 900 MW).

The results of the calculations are displayed in the following tables:

Ethiopian substation and line from Ethiopia to Sudan (Ct1)

Costs (k\$)	I = 12%	I = 10%
Total investment cost (I01+I02)	306 750	295 500
Annuity cost (A)	37 998	31 155
Annual Transmission cost (AT)	53 074	46 232
Energy transmitted (GWh)	6 000	6 000
Transmission cost \$/MWh: Ct1	8.9	7.7

Table 4.2.3-10 - Ethiopian Substation and line from Ethiopia to Sudan

Sudan tapping substation (Ct2)

Costs (k\$)	I = 12%	I = 10%
Total investment cost (I02)	41 100	39 600
Annuity cost (A)	5 240	4 364
Annual Transmission cost (AT)	7 009	6 132
Energy delivered (GWh)	1 500	1 500
Transmission cost \$/MWh: Ct2	4.7	4.1

Table 4.2.3-11 - Sudan tapping substation

Egyptian substation and line from Sudan to Egypt (Ct3)

Costs (k\$)	I = 12%	I = 10%
Total investment cost (I01+I02)	415 550	400 900
Annuity cost (A)	50 831	41 455
Annual Transmission cost (AT)	65 962	56 586
Energy delivered (GWh)	4 500	4 500
Transmission cost \$/MWh: Ct3	14.7	12.6

Table 4.2.3-12 - Egyptian substation and line from Sudan to Egypt

The total transmission cost of one MWh delivered to Egypt is given by the sum: Ct1 + Ct2 + Ct3, while the transmission cost of one MWh delivered to Sudan is given by the sum: Ct1 + Ct2:

Total transmission cost

Discount rate	I = 12%	I = 10%
Total investment cost (I01+I02) (k\$)	763 400	736 000
Transmission cost to Sudan \$/MWh: Ct1 + Ct2	13.6	11.8
Transmission cost to Egypt \$/MWh: Ct1 + Ct2 + Ct3	28.2	24.4

Table 4.2.3-13 - View A3b: ± 500 kV DC double pole line – Investment costs

Equipment	Description	Unit Cost (k\$)	Net Cost (k\$)	Unit Cost (k\$)	Net Cost (k\$)	Capital Cost (k\$)
Markhiat - Mandaya HPP +/- 500 kV DC double pole line	750	209	156 750	202	151 500	126 000
Assiut – Markhiat +/- 500 kV DC double pole line	1450	209	303 050	202	292 900	243 600
AC/DC converter - Mandaya	1 x 1200	125	150 000	120	144 000	120 000
DC/AC converter - Markhiat	1 x 300	137	41 100	132	39 600	33 000
DC/AC converter – Assiut	1 x 900	125	112 500	120	108 000	90 000
Total Cost			763 400		736 000	612 600

Table 4.2.3-14 - View A3b: ± 500 kV double pole line – Cost of losses

Transmission Losses	R (Ω /km)	l (km)	R (Ω)	I (kA)	Losses (MW)	e (MWh)	Cost of losses (k\$)
Markhiat - Mandaya HPP line	0.016	750	12.00	1.20	34.56	172 800	6 912
Assiut - Markhiat line	0.016	1 450	23.20	0.90	37.58	187 920	7 517
Mandaya AC/DC converter J losses (5 000 h)					7.20	36 000	1 440
Mandaya AC/DC converter losses (8 760h)					7.20	63 072	2 523
Khartoum AC/DC converter J losses (5 000h)					1.80	9 000	360
Khartoum AC/DC converter losses (8 760 h)					1.80	15 768	631
Assiut AC/DC converter J losses (5 000 h)					5.40	27 000	1 080
Assuit AC/DC converter losses (8 760 h)					5.40	47 304	1 892
Auxiliary losses					7.20	63 072	2 523
Total losses					108.14	621 936	24 877

Table 4.2.3-15 - View A3b: \pm 500 kV double pole line – O&M costs

Operation and maintenance costs	Capital cost (k\$)	Rate	Annual cost (k\$)
Markhiat - Mandaya HPP line	126 000	0.01	1260
Assiut - Markhiat line	243 600	0.01	2436
AC/DC converter station at Mandaya	120 000	0.014	1680
DC/AC converter station at Markhiat	33 000	0.014	462
DC/AC converter station at Assiut	90 000	0.014	1260
Total			7 098

Table 4.2.3-16 - Operation and maintenance costs

4.2.3.5 Reference unit cost

The following Tables list the unit costs considered in the evaluation of the different options.

Module M3: Energy Sector Profile & Projections

Vol 5

Equipment	Size	Capital cost (k\$)	Investment cost (k\$)	Investment cost (k\$)
			I = 12%	I = 10%
Overhead lines		Per km	Per km	Per km
500 kV single circuit	4 x 280 mm ² (DOVE)	210	262	253
500 kV double circuit	4 x 280 mm ² (DOVE)	357	445	429
400 kV single circuit	2 x 450 mm ²	130	154	150
400 kV double circuit	2 x 450 mm ²	222	264	256
Switchgear		Per unit	Per unit	Per unit
500 kV line bay	DBB	2 200	2 464	2 420
500 kV line bay	One and half breaker	2 900	3 248	3 190
500 kV transformer bay	DBB	1 940	2 173	2 134
400 kV line bay	DBB	1 294	1 450	1 423
400 kV transformer bay	DBB	1 150	1 290	1 265
Transformer	Single phase			
500/400 kV transformer	220 MVA	3 830	4 546	4 424
500/400 kV transformer	185 MVA	3 390	4 026	3 915
Shunt reactor		Per MVA _r		
500 kV	-	60	67	66
500 kV SR bay		980	1 100	1 080

Table 4.2.3-17 - AC transmission equipment unit costs

Note: Investment Cost includes Interest During Construction (IDC)

Module M3: Energy Sector Profile & Projections

Vol 5

Equipment	Size	Capital cost (k\$)	Investment cost (k\$) I = 12%	Investment cost (k\$) I = 10%
Overhead lines		Per km		
+/- 500 kV double pole	6 x 280 mm ²	168	209	202
+/- 500 kV single pole	6 x 280 mm ²	101	126	121
AC/DC converter station	900 or 1 200 MW	100 k\$/MW	125	120
AC/DC converter station	300 MW	110 k\$/MW	137	132

Table 4.2.3-18 - DC transmission equipment unit costs

Note: Investment Cost includes Interest During Construction (IDC)

A: Discount rate I = 12%

AC 500 kV line:

Disbursement schedule.

Year – 3	Year –2	Year -1
30%	30%	40%

$$IDC = (1+i)^3 \times 0.3 + (1+i)^2 \times 0.3 + (1+i) \times 0.4 = 1.246$$

AC 400 kV line:

Disbursement schedule.

Year – 2	Year –1
50%	50%

$$IDC = (1+i)^2 \times 0.5 + (1+i) \times 0.5 = 1.187$$

Substation equipment:

Disbursement schedule.

Year – 1
100%

$$IDC = 1.12$$

Transformer:

Disbursement schedule.

Year – 2	Year –1
50%	50%

$$IDC = (1+i)^2 \times 0.5 + (1+i) \times 0.5 = 1.187$$

DC +/- 500 kV line:

Disbursement schedule.

Year – 3	Year –2	Year -1
30%	30%	40%

$$IDC = (1+i)^3 \times 0.3 + (1+i)^2 \times 0.3 + (1+i) \times 0.4 = 1.246$$

AC/DC converter:

Disbursement schedule.

Year – 3	Year –2	Year -1
30%	30%	40%

$$IDC = (1+i)^3 \times 0.3 + (1+i)^2 \times 0.3 + (1+i) \times 0.4 = 1.246$$

B: Discount rate I = 10%

AC 500 kV line:

Disbursement schedule.

Year – 3	Year –2	Year -1
30%	30%	40%

$$IDC = (1+i)^3 \times 0.3 + (1+i)^2 \times 0.3 + (1+i) \times 0.4 = 1.2023$$

AC 400 kV line:

Disbursement schedule.

Year – 2	Year –1
50%	50%

$$IDC = (1+i)^2 \times 0.5 + (1+i) \times 0.5 = 1.155$$

Substation equipment:

Disbursement schedule.

Year – 1
100%

$$IDC = 1.10$$

Transformer:

Disbursement schedule.

Year – 2	Year –1
50%	50%

$$IDC = (1+i)^2 \times 0.5 + (1+i) \times 0.5 = 1.155$$

DC +/- 500 kV line:

Disbursement schedule.

Year – 3	Year –2	Year -1
30%	30%	40%

$$IDC = (1+i)^3 \times 0.3 + (1+i)^2 \times 0.3 + (1+i) \times 0.4 = 1.2023$$

AC/DC converter:

Disbursement schedule.

Year – 3	Year –2	Year -1
30%	30%	40%

$$IDC = (1+i)^3 \times 0.3 + (1+i)^2 \times 0.3 + (1+i) \times 0.4 = 1.2023$$

Table 4.2.3-19 - Calculation of Interest During Construction (IDC)

4.3 CONCLUSION

Four interconnection alternatives have been identified:

- two AC solutions,
- two DC solutions, one with DC/AC tapping substation at Khartoum and one without.

The transmission costs per MWh have been calculated based on the following hypothesis:

- Exportation from Ethiopia to Egypt and Sudan 5 000 h/year.
- Life duration of 50 years for transmission lines and 25 years for substations.
- The sensitivity of the cost to discount rates of 10% and 12% have been analysed.

The results are displayed here after:

Alternatives	Transmission Costs (\$/MWh)	
	i=12%	i=10%
A1: 500 kV AC single circuit line (600 MW)	24.4	20.9
A2: 500 kV AC double circuit line (1 000 MW)	30.6	26
A3a: +/- 500 kV double pole line, without tapping station (1 200 MW)	21.9	19.1
A3b: +/- 500 kV double pole line, with tapping station (1 200, 900 and 300 MW) *	28.2	24.4

Table 4.3.1 - Transmission costs per MWh for the identified interconnection options

* For this preliminary analysis, the DC lines are similar in the two DC alternatives.

These results confirm that to transmit a huge power over a long distance, such as between Ethiopia and Egypt, DC solutions are the less expensive ones.

For the coming step of the study, Module 6, other alternatives – connection points, line route and technical characteristics - will be investigated. They will be designed according to the results of the economic study - power exchange, duration of exchange and the HPP location. In particular, a mix solution, combining AC and DC links, could be considered.

5. FIRST INDICATIONS OF ECONOMIC PROFITABILITY OF EXPORTS TO EGYPT

5.1 INTRODUCTION

The purpose of this paragraph 5 is to:

- present the basic principle on which economic power trades are founded,
- carry out a simplified analysis focused on the power exports from Ethiopia / Sudan area to Egypt.

Economic power trades:

Economic power trades are grounded on the cost differences of power generation in neighbouring countries. The presence of interconnection allows to supply one country at some particular moment with lower cost generation available in other country. This supply may not be continuous, and may vary in direction and intensity according to the nature of the power mixes (demand variation, hydrology, etc).

In the economic study (Module 6) the amount of power trades between Egypt, Ethiopia and Sudan, and the resulting benefits for the region, will be assessed along two approaches (as per TOR): tight pool model and loose pool model, which can be understood as two stages of development of a power market. These two models are described hereafter.

Fully integrated power system (or Tight Pool model):

A fully integrated regional power system would lead to the lowest cost for the region. In this theoretical situation, all the interconnected power mixes would be operated as a single one, on the basis of a global (i.e. regional) merit order (i.e. from least cost to the most expensive generations units) from a single dispatch centre. At any partial moment (hour, day, year) the total demand would be supplied by the lowest cost generation unit available in the region. Furthermore, in this theoretical model, the investment generation expansion plan would be also optimised at a regional level allowing to take advantage of the countries complementary resources (low cost hydro generation in a country, low cost thermal generation in an other, etc).

Of course, even in this theoretical case some part of the generation would be still dispatched on a non economic basis (e.g. when irrigation is priority), and the transmission and distribution network would set limits to amount of power exchanges possible between the different areas.

Nevertheless, this theoretical approach (fully integrated system) is very informative because it gives at evaluation of the maximum possible benefits (as far as power is concerned) which could be reached if an interconnection is available within a "perfect" power market.

This regional operation and investment regional optimisation (or coordination) would result in:

- operation cost savings (expensive fuel in one country would be substituted by lower cost generation fuel available in another country),

- investment savings (the commissioning of some "expensive" plants might be postponed if firm capacity is available from another country through the interconnection, leading to a larger development of lower cost generation in another country).

Accordingly, both operation (fuel) and investment would be coordinated in the tight pool model.

Loose Pool model:

In this model, only operation is coordinated on a regional basis (or regional dispatch centre). The generation expansion plan (i.e. the generation investment) are left unchanged. This model would represent a situation where the different countries would like to preserve their independence as far as investments are considered, while grasping every operational savings (fuel cost savings).

Development of a power pool:

The two power pool models described previously could be understood as two stages of development of a power market:

- The classic first stage in the establishment of a power market is the development of a spot market where the different actors can buy or sell energy on a day-ahead time horizon. Then a forward market could develop where actors could buy or sell energy on month + n time horizon. This means that actors have the choice between buying / selling energy on the power market or operating their own generation mix. This is the situation represented by the "loose pool" model: the investment decisions are made independently by each actors (or country), but the operating decisions (i.e. which are the units to run) are coordinated through the existence and price signals of the power market. This result in a global reduction of the operating cost.
- In a fully developed power market, further to being able to buy or sell energy on a day-ahead to month + n time horizon, actors could buy or sell energy for year + n time horizon. This means that actors have the choice between buying / selling energy on the power market or investing in new generation units of their own. This is the situation represented by the "tight pool" model: the operating decision (i.e buy/sell on the market or operate), and also investment decisions (i.e buy/sell on the market or invest), are now coordinated though the existence and price signals of the power market. This result in a global reduction of the operating cost and of the investment cost.

A first analysis of the profitability of power export:

The approach along these two models of power poll will be the core of Module 6 economic study and simulations. The simulations of the operation of the generation mixes system in presence of an interconnection (either tight or loose pool model) requires the use of a sophisticated planning model which will be presented in Module 6.

Nevertheless, some good indications of the profitability of economic trade could be obtained by the comparison of the economic cost of the generation units involved. This simplified approach is useful because it provides a direct link between the main hypothesis (Natural Gas cost, transmission cost, CCGT investment cost) and allow to pin point the parameters having the most important impact on the results.

Indeed, on the basis of the data gathered in Module 3. It is possible to give some indications of the conditions of profitability of export of hydro power from Sudan / Ethiopia area to Egypt.

The power generated by hydro plant in Ethiopia or Sudan and transported by the interconnection is in competition with semi-base generation units in Egypt, namely new gas-fired CCGT.

The interconnection is economically founded if the average cost of the MWh supplied to Egypt through the interconnection is lower than the average cost of the MWh directly supplied by a gas-fired CCGT in Egypt.

More precisely, the two terms (expressed in USD/MWh) to be compared are:

- economic cost of gas-fired CCGT in Egypt for semi-base generation.
- economic cost of large hydro generation in Ethiopia or Sudan added to the levelized cost of interconnection.

These two terms are described and discussed in the following two paragraphs.

Obviously, the objective of this first simplified analysis is not to substitute to the economic analysis which take place in Module 6. The purpose here is to give through a global approach some indications on the maximum cost of HPP and interconnection which would preserve the economic profitability of the interconnection project given one of the most important hypothesis of the Study.

The economic approach of Module 6 based on the Generation Expansion Plan determination will be more precise, because of the consideration of:

- description of the three generation mixes in Egypt, Ethiopia and Sudan.
- description of the hydro schemes.
- description of the demand of each countries.

The possibility of re-enforcement of exchanges between Ethiopia and Sudan will also be considered in Module 6.

5.2 LOAD FACTOR OF THE INTERCONNECTION

In order to be profitable, the load factor of the interconnection should be large enough to pay back the investment cost. Emergency exchanges alone would not justify such a large investment. Accordingly semi-base power exchanges are considered here, with a 5 000 hours annual duration, which is consistent with the availability of hydro generation from well regulated reservoirs. This value should be considered only as a reasonable starting point to illustrate this simplified analysis. In the course of the economic Study carried out in Module 6 the optimal duration of the power exchanges will be evaluated by a stochastic model on the base of a detailed description of the three power mixes.

5.3 ECONOMIC COST OF GAS-FIRED CCGT IN EGYPT

The following characteristics are considered for the generic gas-fired CCGT candidate installed in new sites in Egypt (see Module 3 Vol2):

	Unit	Value
Installed capacity	MW	750
De-rating (5%)	MW	38
Auxiliary consumption (3%)	MW	21
Net capacity	MW	691
Net efficiency	%	52%
Availability	%	94%
Specific construction cost	USD ₂₀₀₆ /KW	600
Fixed O&M cost	USD/(kW.year)	16.29
Variable O&M cost	USD/MWh	0.161
Economic life	year	25
Disbursement schedule :		
year - 2 :	%	50%
year - 1 :	%	50%

Table 4.2.3-1 - Economic characteristics of the generic gas-fired CCGT in Egypt

On this base, it is possible to calculate the economic cost² of the generic gas-fired Egyptian CCGT.

Definition and calculation of the economic cost of generation:

The economic cost of generation can be understood as the average cost of generation all over the economic life of the investment. given all costs (investment cost. variable and fixed O&M cost. fuel cost) and the discount rate.

The economic cost is a straightforward way to make a quick comparison between different types of generation (TPP. HPP. etc).

$$\text{economic cost (h)} = (A + K \times h) / h$$

where:

h = annual generation duration (unit = hours)

A = anticipation cost of one guaranteed MW of facility (unit = USD/ (MW.year))

K = proportional cost (fuel. O&M proportional cost) (unit = USD /MWh)

The anticipation cost³ of one guaranteed MW is equal to the sum of the fixed annual costs of the facility:

$$A = (a + K_{fix}) / k_{avail}$$

where:

a = investment annuity of one installed MW = (construction cost + IDC) / K (r.d).

K_{fix} = annual O&M cost.

k_{avail} = availability factor (considering forced and planned outage rate).

IDC = interest during construction.

r = discount factor.

d = economic life duration.

$$K (r.d) = \frac{r \times (1+r)^d}{(1+r)^d - 1} \times \frac{1}{(1+r)^{0.5}}$$

² Also called "levelized cost"

³ Called "anticipation cost" because it is equal to the fixed cost paid when the commissioning of the facility i is anticipated by one year.

If an annual generation of 5 000 hours/year and a discount rate of 12% are assumed, the following figure gives the evolution of the economic cost of CCGT along the period of study according the three projections of Natural Gas price presented in § 3.1.2.2.

The use of a 10% discount rate would shift the curves downward by 3.0 USD/MWh.

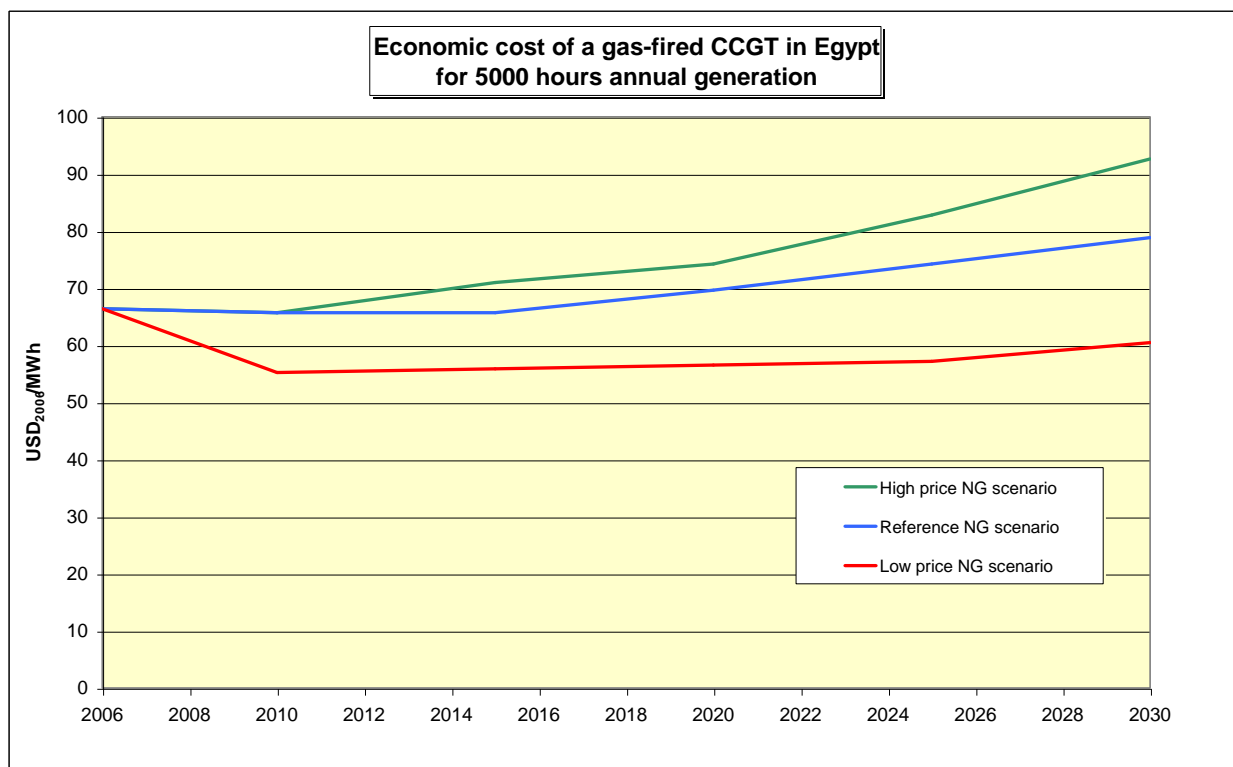

Figure 5.3-1 - Economic cost of generic gas-fired CCGT in Egypt

If we considered the situation in 2015, which is the earliest time of commission of the interconnection, given the construction duration of large HPP and of the interconnection, the previous figure shows that the total economic cost (HPP + interconnection) of the MWh supplied to Egypt through the interconnection should be lower than the following values in order to be competitive with Egyptian CCGT:

- 71 USD/MWh, in the high price natural gas scenario,
- 65 USD/MWh, in the reference natural gas scenario,
- 56 USD/MWh, in the low price natural gas scenario.

The profitability of the interconnection increased with time in line with the general increase of natural gas price. If it is committed in 2020, the total economic cost (HPP + interconnection) of the MWh supplied to Egypt, should be lower than the following values in order to be competitive with Egyptian CCGT:

- 74 USD/MWh. in the high price natural gas scenario,
- 70 USD/MWh. in the reference natural gas scenario,
- 56 USD/MWh. in the low price natural gas scenario.

NB: if the discount rate was 10% instead of 12%, all the previous economic costs would be shifted downward by 3.0 USD/MWh.

5.4 ECONOMIC COST OF HYDRO POWER DELIVERED TO EGYPT

The economic cost of hydro power delivered to Egypt is the sum of the economic cost of HPP supplying this energy (USD/MWh) and the economic cost of the interconnection (USD/MWh).

5.4.1 ECONOMIC COST OF HPP

The analysis of the hydro candidates in Ethiopia and Sudan shows that, for a 12% discount rate, the best projects have an economic cost in the range of 40 to 45 USD/MWh.

For a 10% discount rate, the economic cost of HPP would shift downward by about 5 USD/MWh (compared to the 3.0 USD/MWh reduction for the gas-fired CCGT).

Accordingly, two situations will be considered in the following analysis:

- 40 USD/MWh HPP and 12% discount rate,
- 35 USD/MWh HPP and 10% discount rate.

5.4.2 ECONOMIC COST OF THE INTERCONNECTION

The following Table summarizes the main characteristics of the first views of the interconnection:

	V A1	V A2	V A3a	V A3b
Voltage	500 kV AC	500 kV AC	± 500 kV DC	± 500 kV DC
Transfer capacity	600 MW	1 000 MW	1 200 MW	Sudan: 300 MW Egypt : 900 MW
Investment cost	465 MUSD	1 025 MUSD	760 MUSD	764 MUSD
Economic cost				
- 12% discount rate:	24.4 USD/MWh	30.6 USD/MWh	21.9 USD/MWh	28.2 USD/MWh
- 10% discount rate:	20.9 USD/MWh	26.0 USD/MWh	19.1 USD/MWh	24.4 USD/MWh

Table 5.4.2-1 - Economic cost of the interconnection options

At this stage of analysis, view A2 is clearly less economical than views A1 and A3. Nevertheless, as mentioned previously the designs are not optimised and these figures are provided mainly to give an idea of the investment required.

5.5 DISCUSSION

From the previous data, it is possible to make a first comparison between:

- the economic cost of gas-fired Egyptian CCGT generation,
- the economic cost of hydro generation supplied to Egypt through the interconnection.

5.5.1 EXPORTS FROM A 40 USD/MWH HPP AND 12% DISCOUNT RATE

The 12% is the "high" value of the discount rate considered in the sensitivity analysis (see justification in Module M4). This value could be considered as providing conservative results.

The following figure completes the previous **Figure 5.3-1** with the addition of the cost of hydro generation supplied to Egypt for the three interconnection views.

For the purpose of simplification, a 40 USD/MWh economic cost of hydro generation (without interconnection) is assumed. This value is representative of the lower cost extra hydro generation available for exports for up to 2030. A greater or lower cost would imply a shift upward or downward of the following figure:

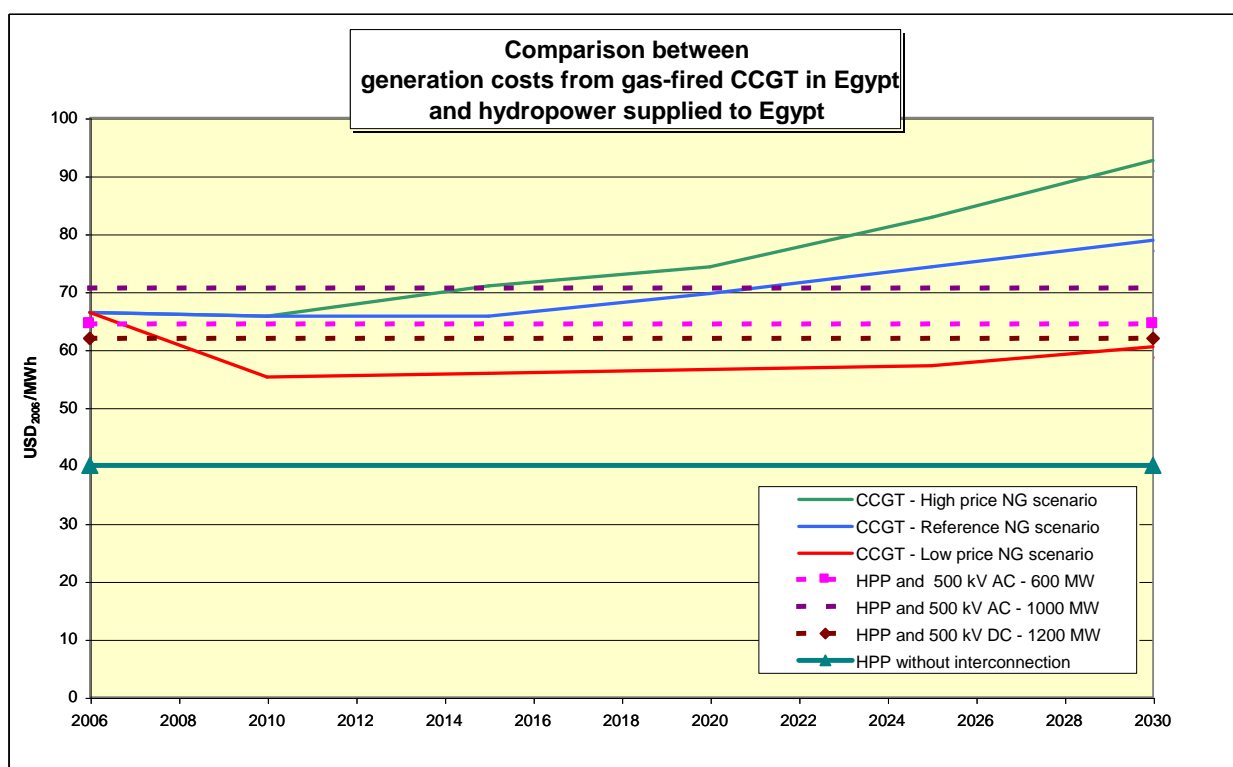

Figure 5.5-1 - Comparison of cost between CCGT and hydropower supplied to Egypt – 12% discount rate

Reference and high natural gas price projection:

From 2015, which is earliest commissioning date for the interconnection, and if the energy exported to Egypt is supplied from a 40 USD/MWh HPP, exports become more competitive than Egyptian CCGT for the two interconnection views 500 kV DC 1200 MW and 500 kV AC 600 MW.

In the high price gas projection, even the most expensive interconnection view, 500 kV AC 1 000 MW, becomes competitive from about 2015.

Low price natural gas projection:

If the natural gas price remains low, then it is not possible to expect any economic profitability of power export to Egypt from a 40 USD/MWh HPP, even in 2030.

Threshold price of natural gas:

From the previous figures, it is possible to found that the threshold price of gas, leading to profitability or not, of hydro generation export to Egypt is in the range of 6.0 to 6.2 USD/MBTU.

5.5.2 EXPORTS FROM A 35 USD/MWH HPP AND 10% DISCOUNT RATE

The reference discount rate for the economic Study in Module 6 is 10% (see justification in Module 4). Compared to a 12% value, a 10% rate would favour large and long term investments (e.g HPP and the interconnection) against lower investments with short economic lives (e.g CCGT).

In other words, a 12% discount rate would favour short term versus long term while a 10% would give more weight to long term.

As noted before, the shift from 12% to 10% discount rate decreases the economic cost of CCGT by 3.0 USD/MWh, and decreases, by a larger amount of 5 USD/MWh, the HPP economic cost (40 USD/MWh to 35 USD/MWh) and the interconnection economic cost by 2 to 4 USD/MWh.

Accordingly the general competitiveness of the hydro power delivered to Egypt would be reinforced as can be observed in the following figure:

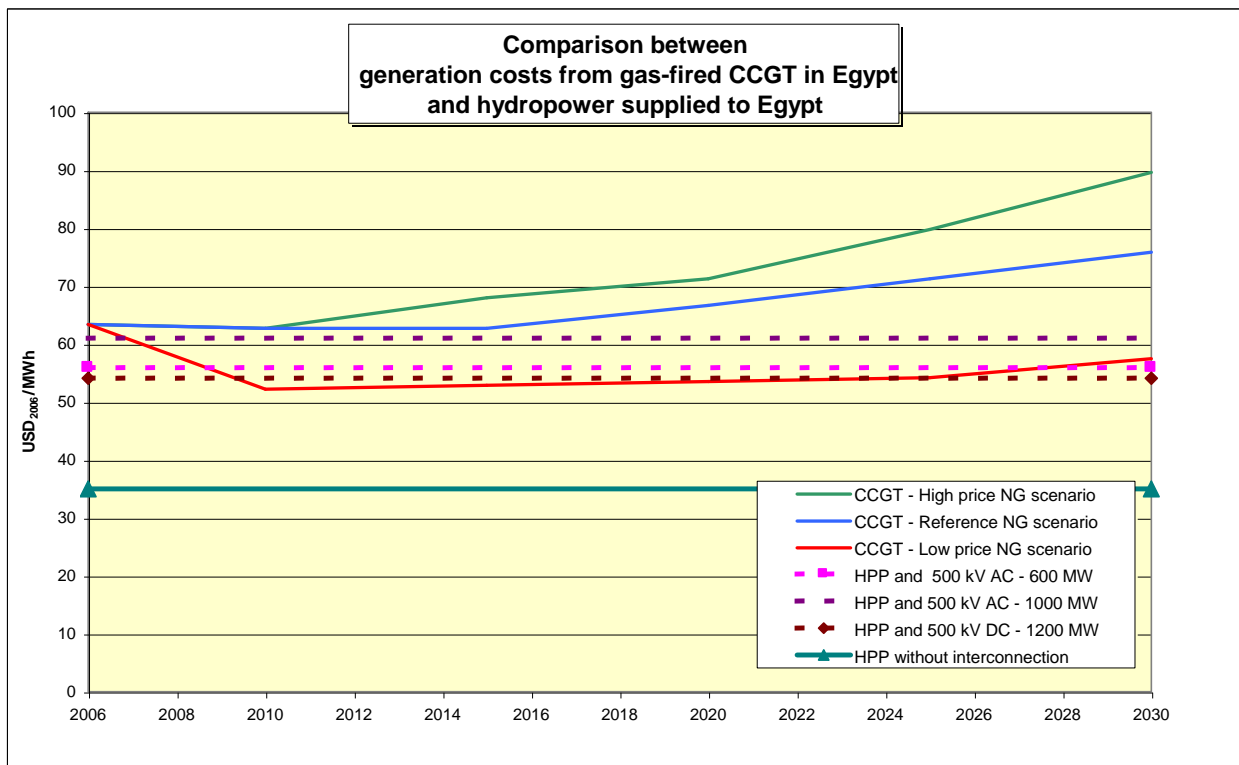

Figure 5.5-2 - Comparison of cost between CCGT and hydropower supplied to Egypt – 10% discount rate

High and reference natural gas price projection:

With a 10% discount rate, the power exports from a 35 USD/MWh HPP are competitive for the earliest date of commissioning of the interconnection (2015).

Low natural gas price projection:

If the natural gas price remains low, economic profitability of power export to Egypt from a 35 USD/MWh HPP would not be achieved before 2025-2030 even for the lowest cost interconnection views.

Threshold price of natural gas:

From the previous figures, it is possible to find that the threshold price of gas, leading to profitability or not, of hydro generation export to Egypt is in the range of 5.2 to 5.5 USD/MBTU.

5.5.3 IMPACT OF DEMAND PROJECTIONS ON THE INTERCONNECTION PROFITABILITY

The previous analysis shows that the following factors are of paramount importance in the economic analysis of the interconnection:

- natural gas price,
- CCGT investment cost,
- HPP investment cost,
- discount rate.

It could be noted that the demand forecast hypothesis has less importance:

Egypt: Whatever the demand forecast projection, the development of new base and semi-base generation is made with gas-fired CCGT power plant. A higher or lower demand simply results in more or less CCGT to be committed. The same gas-fired CCGT would still remain the semi-base load supply candidate to which exported hydro generation must compete. Accordingly, the demand forecast hypothesis of Egypt (High, Medium or Low) has no impact on the profitability of the interconnection.

Ethiopia and Sudan: The level of demand in these countries (and the possible power exports to other countries, like Kenya) has an impact on the cost of the extra hydro generation available for export to Egypt. In the high demand scenario, a large volume of the hydro generation is needed for the internal power demand of Ethiopia and Sudan, which results in the lowest cost HPP being used to supply the national demand. Accordingly, the cost generation available for export will be greater than in reference (or low) demand projection.

5.6 CONCLUSION

The profitability of the power exports from the Ethiopia - Sudan area to Egypt is determined by the competition between gas-fired CCGT in Egypt and hydro power supplied to Egypt through the interconnection. The interconnection is economically founded if the average cost of the MWh supplied to Egypt through the interconnection is lower than the average cost of the MWh directly supplied by a gas-fired CCGT in Egypt.

From the previous first views of interconnection options and costs, it is possible to compare:

- the economic cost of gas-fired Egyptian CCGT generation,
- the economic cost of hydro generation supplied to Egypt through the interconnection.

The economic costs of generation and transmission depend on investment cost, operation cost (fuel and O&M) and also on discount rate. A high value of discount rate would give more weight to short term, and would disfavour large and long term investments (e.g. HPP and interconnection) compared to lower investments with short economic lives (e.g. CCGT).

The reference discount rate for the economic Study carried out in Module 6 is 10% (see justification in Module 4). A 12% rate will be considered in the sensitivity analysis.

From the first views of the interconnection (technology, route, capacity, etc), it is found that:

- For the reference discount rate used in this Study (10%), power exports from Ethiopia – Sudan area supplied from a 35 USD/MWh HPP (typical value of the lowest cost HPP identified in Module 3 Vol 3 and 4), would become competitive when the natural gas price in Egypt is greater than a range of 5.0 to 5.5 USD/MBTU. This value is significantly exceeded in the 2015, which is the earliest date of commissioning of the interconnection, in both reference and high projection of natural gas price. This means that the interconnection would become profitable from its earliest possible date of commissioning.

If the natural gas price remains low, economic profitability of power export to Egypt from a 35 USD/MWh HPP would not be achieved before 2025-2030, even for the lowest cost interconnection options.

- For a 12% discount, which could be considered as a conservative value, the typical value of the lowest cost HPP is 40 USD/MWh in the Sudan / Ethiopia area. Hydro power exports would become competitive when the price of natural gas in Egypt is greater than a range of 6.0 to 6.2 USD/MBTU.

This value is exceeded in the 2015, for the two lower cost options identified for the interconnection for both high and reference natural gas price projection. In the high price gas projection, the most expensive interconnection option, 500 kV AC 1 000 MW, would become competitive from about 2015.

If the natural gas price remains low, then it is not possible to expect any economic profitability of power export to Egypt from a 40 USD/MWh HPP, even in 2030.

Module M3: Energy Sector Profile & Projections

Vol 5

At this stage of the Study, these figures and results are to be considered as purely indicative because they are based on a simplified economic approach, preliminary identification of interconnection alternatives. Nevertheless they strongly support the confidence in the profitability of the interconnection from 2015.

The purpose of Module 6, through the economic study, generation expansion plan determination and interconnection optimisation (design and line route), will be to confirm this economic profitability and to precisely assess the associated benefits for the region.

ENTRO



EDF – Generation and Engineering
Division
73 373
Le Bourget du Lac Cedex
France
Tel: +33-4-79 60 60 28
Fax: +33-4-79 60 62 35
eMail: pierre.brun@edf.fr
<http://www.edf.fr>

EASTERN NILE POWER TRADE PROGRAM STUDY

AfDB



Scott Wilson
Kanthack House, Station Road,
Ashford, Kent TN 23 1 PP
England
Tel: +44 (0) 1233 658200
Fax: +44 (0) 1233 658209
eMail: alan.bates@scottwilson.com
<http://www.scottwilson.com>

ENERGY SECTOR PROFILE & PROJECTIONS

VOL 5

with participation of:

- EPS (Egypt)
- Tropics (Ethiopia)
- YAM (Sudan)

FINAL APPENDIX

June 2007



TABLE OF CONTENTS

1. FUEL PRICE PROJECTION	4
2. USEFUL UNITS AND ENERGY CONVERSION FACTORS	7

LIST OF TABLES

TABLE 1-1 - FUEL PRICE PROJECTION – LOW SCENARIO.....	4
TABLE 1-2 - FUEL PRICE PROJECTION - MEDIUM SCENARIO	5
TABLE 1-3 - FUEL PRICE PROJECTION – MEDIUM SCENARIO.....	6

1. FUEL PRICE PROJECTION

FUEL PRICE PROJECTION - LOW SCENARIO

	Low sulfur crude oil	Natural gas	Coal	Low sulfur crude oil	HFO	Diesel	Gasoil
	USD2006/bbl	USD2006/Mbtu	USD2006/t	USD2006/t	USD2006/t	USD2006/t	USD2006/t
2003	33.3	6.5	63.0	242.9	165.2	303.6	364.4
2004	42.5	6.5	63.0	310.1	210.8	387.6	465.1
2005	58.7	6.5	63.0	428.3	291.2	535.4	642.4
2006	62.0	6.5	63.0	452.6	307.7	565.7	678.9
2007	56.5	6.08	63.0	412.4	280.4	515.5	618.6
2008	51.3	5.65	63.0	374.3	254.5	467.8	561.4
2009	47.1	5.23	63.0	343.9	233.8	429.9	515.8
2010	42.3	4.8	63.0	308.5	209.8	385.7	462.8
2011	40.7	4.8	63.0	297.0	202.0	371.2	445.5
2012	39.4	4.8	63.0	287.7	195.6	359.6	431.6
2013	37.7	4.9	63.0	275.3	187.2	344.1	412.9
2014	36.2	4.9	63.0	264.0	179.6	330.1	396.1
2015	35.4	4.9	63.0	258.7	175.9	323.4	388.1
2016	35.6	4.9	63.0	259.7	176.6	324.6	389.6
2017	35.6	4.9	63.0	259.7	176.6	324.6	389.5
2018	35.3	5.0	63.0	257.8	175.3	322.2	386.7
2019	34.1	5.0	63.0	248.6	169.1	310.8	372.9
2020	35.7	5.0	63.0	260.3	177.0	325.3	390.4
2021	35.1	5.0	63.0	256.2	174.2	320.3	384.3
2022	36.0	5.0	63.0	262.7	178.6	328.3	394.0
2023	36.0	5.1	63.0	262.9	178.8	328.6	394.3
2024	35.5	5.1	63.0	258.9	176.0	323.6	388.3
2025	36.1	5.1	63.0	263.7	179.3	329.7	395.6
2026	36.3	5.4	63.0	265.0	180.2	331.3	397.5
2027	35.9	5.7	63.0	262.0	178.1	327.4	392.9
2028	36.0	6.0	63.0	262.6	178.6	328.2	393.9
2029	35.8	6.3	63.0	261.5	177.8	326.9	392.3
2030	35.4	6.6	63.0	258.3	175.6	322.8	387.4

Table 1-1 - Fuel price projection – Low scenario

**Module M3: Energy Sector Profile & Projections
Vol 5**

FUEL PRICE PROJECTION - MEDIUM SCENARIO

	Low sulfur crude oil	Natural gas	Coal	Low sulfur crude oil	HFO	Diesel	Gasoil
	USD2006/bbl	USD2006/Mbtu	USD2006/t	USD2006/t	USD2006/t	USD2006/t	USD2006/t
2003	33.3	6.5	63.0	242.9	165.2	303.6	364.4
2004	42.5	6.5	63.0	310.1	210.8	387.6	465.1
2005	58.7	6.5	63.0	428.3	291.2	535.4	642.4
2006	62.0	6.5	63.0	452.6	307.7	565.7	678.9
2007	58.3	6.47	63.0	425.9	289.6	532.4	638.9
2008	54.9	6.45	63.0	400.5	272.3	500.6	600.8
2009	52.6	6.42	63.0	384.0	261.1	480.0	576.0
2010	49.6	6.4	63.0	362.1	246.2	452.6	543.2
2011	49.7	6.4	63.0	362.5	246.5	453.2	543.8
2012	50.0	6.4	63.0	364.9	248.1	456.1	547.3
2013	49.7	6.4	63.0	362.8	246.7	453.5	544.2
2014	49.2	6.4	63.0	359.2	244.2	449.0	538.7
2015	50.1	6.4	63.0	366.0	248.9	457.5	548.9
2016	50.6	6.5	63.0	369.1	251.0	461.3	553.6
2017	50.7	6.6	63.0	369.9	251.6	462.4	554.9
2018	51.7	6.7	63.0	377.1	256.4	471.3	565.6
2019	50.7	6.9	63.0	370.4	251.9	463.0	555.6
2020	53.2	7.0	63.0	388.2	264.0	485.3	582.4
2021	53.0	7.1	63.0	386.9	263.1	483.7	580.4
2022	55.1	7.3	63.0	402.1	273.4	502.6	603.1
2023	55.7	7.4	63.0	406.9	276.7	508.6	610.3
2024	54.6	7.6	63.0	398.7	271.1	498.3	598.0
2025	56.7	7.7	63.0	414.1	281.6	517.7	621.2
2026	57.5	7.9	63.0	419.7	285.4	524.6	629.5
2027	58.4	8.0	63.0	426.6	290.1	533.3	639.9
2028	59.1	8.1	63.0	431.5	293.4	539.3	647.2
2029	59.5	8.3	63.0	434.5	295.4	543.1	651.7
2030	59.8	8.4	63.0	436.2	296.6	545.3	654.3

Table 1-2 - Fuel price projection - Medium scenario

**Module M3: Energy Sector Profile & Projections
Vol 5**

FUEL PRICE PROJECTION - MEDIUM SCENARIO

	Low sulfur crude oil	Natural gas	Coal	Low sulfur crude oil	HFO	Diesel	Gasoil
	USD2006/bbl	USD2006/Mbtu	USD2006/t	USD2006/t	USD2006/t	USD2006/t	USD2006/t
2003	33.3	6.5	63.0	242.9	165.2	303.6	364.4
2004	42.5	6.5	63.0	310.1	210.8	387.6	465.1
2005	58.7	6.5	63.0	428.3	291.2	535.4	642.4
2006	62.0	6.5	63.0	452.6	307.7	565.7	678.9
2007	62.2	6.47	63.0	453.8	308.6	567.3	680.7
2008	62.8	6.45	63.0	458.4	311.7	573.1	687.7
2009	64.1	6.42	63.0	468.1	318.3	585.1	702.1
2010	65.7	6.4	63.0	479.8	326.2	599.7	719.7
2011	68.2	6.6	63.0	497.7	338.4	622.1	746.5
2012	71.0	6.8	63.0	518.0	352.2	647.5	776.9
2013	74.1	7.0	63.0	541.1	368.0	676.4	811.7
2014	76.9	7.2	63.0	561.4	381.8	701.7	842.1
2015	80.0	7.4	63.0	584.3	397.3	730.3	876.4
2016	82.1	7.5	63.0	599.3	407.5	749.1	898.9
2017	83.3	7.6	63.0	608.2	413.6	760.2	912.3
2018	85.3	7.7	63.0	622.8	423.5	778.5	934.2
2019	85.9	7.8	63.0	627.0	426.3	783.7	940.4
2020	89.2	7.9	63.0	651.3	442.9	814.2	977.0
2021	89.8	8.1	63.0	655.8	445.9	819.8	983.7
2022	92.2	8.3	63.0	673.3	457.8	841.6	1009.9
2023	93.3	8.6	63.0	681.3	463.3	851.7	1022.0
2024	92.7	8.8	63.0	676.4	460.0	845.5	1014.7
2025	94.7	9.0	63.0	691.3	470.1	864.1	1036.9
2026	95.9	9.3	63.0	699.9	475.9	874.9	1049.8
2027	97.0	9.6	63.0	708.4	481.7	885.5	1062.6
2028	98.1	9.9	63.0	716.3	487.1	895.4	1074.5
2029	99.3	10.2	63.0	724.6	492.7	905.7	1086.9
2030	100.4	10.5	63.0	733.0	498.4	916.2	1099.4

Table 1-3 - Fuel price projection – Medium scenario

2. USEFUL UNITS AND ENERGY CONVERSION FACTORS

ENERGY UNIT CONVERSION TABLE

1 unit of line i = kij of column j

	toe	tce	m ³ of Natural Gas (1)	metric ton of LNG	1 kWh gas GCV	KWh elec. (2)	KWh elec. (3)	MJ	10 ³ cubic feet	Barrel of crude oil	10 ⁶ B.T.U. (4)
1 toe =	1	1,5	1 000	0,769	12 987	11 626	4 500	41 855	35,31	7,33	39,67
1 tce =	0,6667	1	666,7	0,513	8 658	7 751	3 000	27 903	23,54	4,887	26,45
1 m ³ Natural Gas = (l)	10 ⁻³	1,5.10 ⁻³	1	0,769.10 ⁻³	12,99	11,63	4,5	41,86	0,03531	7,33.10 ⁻³	0,0397
1 t of LNG =	1,3	1,95	1 300	1	16 883	15 114	5 850	54 412	45,90	9,53	51,57
1 kWh gas GCV =	0,077.10 ⁻³	0,1115.10 ⁻³	77,0.10 ⁻³	0,059.10 ⁻³	1	0,895	0,3465	3,2	2,718.10 ⁻³	0,5644.10 ⁻³	3,054.10 ⁻³
1 kWh elec. = (2)	0,0860.10 ⁻³	0,1290.10 ⁻³	86,0.10 ⁻³	0,066.10 ⁻³	1,117	1	0,3874	3,6	3,037.10 ⁻³	0,6305.10 ⁻³	3,412.10 ⁻³
1 kWh elec. = (3)	0,222.10 ⁻³	0,333.10 ⁻³	0,222	0,171.10 ⁻³	2,884	2,581	1	9,292	7,846.10 ⁻³	1,629.10 ⁻³	8,818.10 ⁻³
1 MJ = 10 ⁶ J =	0,0239.10 ⁻³	0,0358.10 ⁻³	0,0239	0,018.10 ⁻³	0,3103	0,2778	0,1076	1	0,8439.10 ⁻³	0,1751.10 ⁻³	0,9478.10 ⁻³
10 ³ cubic feet (Mcf) = gaz naturel (Mft ³)	0,02832	0,04248	28,32	21,79.10 ⁻³	367,8	329,3	127,5	1 185	1	0,2076	1,123
1 crude oil bbl =	0,1364	0,2046	136,4	0,105	1 712	1 586	613,9	5 710	4,818	1	5,411
10 ⁶ B.T.U. = (4) (MM B.T.U.)	0,02521	0,0378	25,21	19,39.10 ⁻³	327,4	293,1	113,4	1 055	0,8902	0,1848	1

(1) 1 m³ de LNG \cong 600 m³ of Natural Gas, 460 kg of LNG

(2) equivalence for consumption

(3) equivalence for generation

(4) 1 Therm = 105 B.T.U. (British Thermal Unit)

103 B.T.U./ft³ \cong 37,3 MJ/m³ \cong 10,4 kWh/m³

N. B. 1 million de cubic feet/day \cong 10 millions m³/an (cubic feet/day = cu.ft/d = cf/d = ft³/d)

1 000 bbl/jour \cong 50 000 metric tons/year

General Conversion Factors for Energy

To:	TJ	Gcal	Mtoe	MBtu	GWh
From:	multiply by:				
TJ	1	238.8	2.388×10^{-5}	947.8	0.2778
Gcal	4.1868×10^{-3}	1	10^{-7}	3.968	1.163×10^{-3}
Mtoe	4.1868×10^4	10^7	1	3.968×10^7	11630
MBtu	1.0551×10^{-3}	0.252	2.52×10^{-8}	1	2.931×10^{-4}
GWh	3.6	860	8.6×10^{-5}	3412	1

bbl	barrel	(1t = 7.3 bbl)
cal	calorie	(1 cal = 4.1868 J)
Gcal	Giga calorie	
GWh	Gigawatt-hour	
h	hour	
km	kilometer	
km ²	square kilometer	
kW	kilo Watt	
kWh	kilo Watt hour	(1 kWh = 3.6 MJ)
MBtu	Million British Thermal Units	(= 1 055 MJ = 252 kCal)
	one cubic foot of natural gas produces approximately 1,000 BTU	
MJ	Million Joule	(= $0,948.10^{-3}$ MBtu = 238.8 kcal)
MW	Mega Watt	
m	meter	
m ³ /d	cubic meter per day	
mm	millimeter	
mm ³	million cubic meter	
Nm ³	Normal cubic meter, i.e. measured under normal conditions, i.e. 0°C and 1013	
mbar		(1 Nm ³ = 1.057 m ³ measured under standard conditions, i.e. 15°C and 1013
mbar)		
t	ton	
toe	tons of oil equivalent	
pcf	ton cubic feet	
°C	Degrees Celsius	