

ENTRO



EDF – Generation and Engineering
Division
73 373
Le Bourget du Lac Cedex
France
Tel: +33-4-79 60 60 28
Fax: +33-4-79 60 62 35
eMail: pierre.brun@edf.fr
<http://www.edf.fr>

EASTERN NILE POWER TRADE PROGRAM STUDY

AfDB

ENERGY SECTOR PROFILE & PROJECTIONS

VOL 3 - ETHIOPIA

FINAL MAIN REPORT

with participation of:

- EPS (Egypt)
- Tropics (Ethiopia)
- YAM (Sudan)

June 2007



TABLE OF CONTENTS

1. OVERVIEW	11
1.1 DEMAND FORECAST.....	11
1.2 POWER TRADE OPPORTUNITIES	11
1.3 IDENTIFICATION OF GENERATION OPTIONS	12
1.3.1 Thermal candidates	12
1.3.2 Hydropower candidates.....	12
1.3.3 Other types of power candidates	14
1.4 REVIEW OF THE EXISTING GENERATION PLAN.....	14
1.5 REVIEW OF THE TRANSMISSION MASTER PLAN	15
2. ORGANISATION OF THE REPORT.....	15
3. REVIEW AND UPDATE OF DEMAND FORECAST	16
3.1 REVIEW OF DEMAND PAST EVOLUTION	16
3.1.1 Background.....	16
3.1.1.1 Development in demography.....	16
3.1.1.2 Characteristics of the Ethiopian Economy	17
3.1.1.3 The Ethiopian Electric System	18
3.1.2 Tariff structures and metering technology	18
3.1.3 Annual energy and peak demand historical evolution.....	21
3.1.3.1 Calendar & fiscal year, time zone.....	21
3.1.3.2 ICS and SCS demand historical evolution.....	21
3.1.3.3 Historical evolution of sales	23
3.1.3.4 Domestic Demand	24
3.1.3.5 Commercial Demand.....	25
3.1.3.6 Street Lighting	25
3.1.3.7 Industrial Demand	26
3.2 DEMAND VARIATION PATTERN.....	26
3.2.1 Daily load variation.....	26
3.2.2 Seasonal load variation.....	28
3.2.3 Load duration curve	29
3.2.4 Load factor	30
3.3 SYSTEM LOSSES.....	30
3.4 REVIEW OF EEPSCO DEMAND FORECAST	31
3.4.1 Overview.....	31
3.4.2 Methodology.....	32
3.4.2.1 Income and price elasticity for the Interconnected System (ICS) demand.....	33
3.4.2.1.1 Domestic Sales Elasticity	33
3.4.2.1.2 Commercial Sales Elasticity.....	33
3.4.2.1.3 Industrial Sales Elasticity.....	34
3.4.2.1.4 Review of the elasticity figures.....	34
3.4.2.2 Unsupplied centers	34
3.4.3 EEPSCO demand Forecast	34
3.4.4 Consultant analysis.....	36
3.5 LOW DEMAND FORECAST	36
3.6 DEMAND FORECAST SUMMARY	37

4. POTENTIAL TRADE OPPORTUNITIES.....	37
4.1 OVERVIEW	37
4.2 POTENTIAL TRADE OPPORTUNITIES	38
4.2.1 General	38
4.2.2 Sudan Market.....	39
4.2.3 Kenyan Market	39
4.2.4 Uganda Market.....	40
4.2.5 Egyptian Market	40
4.2.6 Djibouti Market	40
4.2.7 Somali market.....	41
4.2.8 Eritrea market.....	41
4.2.9 Summary table	41
5. FUEL PRICES.....	42
5.1 PETROLEUM PRODUCTS	42
5.2 COAL.....	43
5.3 NATURAL GAS.....	43
6. GENERATION SUPPLY OPTIONS	44
6.1 TPP CANDIDATES.....	44
6.2 HYDRO POWER PLANT PROJECTS.....	48
6.2.1 Hydro potential per river basin.....	48
6.2.2 Construction and generation cost.....	52
6.2.3 Filling time	52
6.2.4 Presentation of each project.....	53
6.2.4.1 Halele Werabesa (420 MW)	53
6.2.4.2 Chemoga-Yeda (280 MW)	56
6.2.4.3 Aleltu East (186 MW)	59
6.2.4.4 Aleltu West (265 MW).....	60
6.2.4.5 Baro1 & 2 and Genji (900 MW).....	62
6.2.4.6 Geba I & II (370 MW).....	66
6.2.4.7 Gojeb (153 MW)	68
6.2.4.8 Genale III and VI (511 MW).....	70
6.2.4.9 Awash IV (38 MW).....	72
6.2.4.10 Karadobi (1600 MW)	74
6.2.4.11 Mabil (1 200 MW).....	75
6.2.4.12 Mandaya (2 000 MW)	76
6.2.4.13 Border (1200 MW).....	77
6.2.5 Evaporation.....	79
6.2.6 HPP sequencing	79
6.2.7 Summary table of hydro candidates	79
6.2.8 Hydrologic reliability for the System.....	81
6.2.9 Other relevant Data.....	81
6.2.10 Small Hydro Generation.....	81
6.2.11 Schematic configuration of river system.....	82
6.3 OTHER TYPES OF POWER CANDIDATES (GEOTHERMAL, WIND, SOLAR, ETC).....	92
6.3.1 Geothermal generation resources	92
6.3.1.1 Introduction	92
6.3.1.2 The Aluto-Langano geothermal field	92

Module M3: Energy Sector Profile & Projections

VOL 3: ETHIOPIA

6.3.1.3	The Tendaho geothermal field.....	93
6.3.1.4	Hypothesis for the study	93
6.3.2	<i>Wind generation resources</i>	95
6.3.3	<i>Solar Generation Resources</i>	95
7.	REVIEW OF THE EXISTING GENERATION EXPANSION PLAN	96
8.	REVIEW OF THE EXISTING TRANSMISSION MASTER PLAN	99

Module M3: Energy Sector Profile & Projections

VOL 3: ETHIOPIA

LIST OF TABLES

TABLE 1.1-1 - MAIN CHARACTERISTICS OF THE THREE DEMAND PROJECTIONS FOR ETHIOPIA.....	11
TABLE 1.2-1 - POWER EXPORT PROJECTION FOR ETHIOPIA.....	12
TABLE 1.3-1- MAIN CHARACTERISTICS OF THE ETHIOPIAN HYDROPOWER PROJECTS.....	13
TABLE 1.4-1- ETHIOPIAN GENERATION EXPANSION PLAN TO YEAR 2015.....	14
TABLE3.1-1 - RECENT TARIFF HISTORY (BIRR/KWH).....	20
TABLE3.1-2 - COMPARISON OF GDP AND GENERATION ANNUAL GROWTH RATE.....	22
TABLE 3.4-1 - EPSEMPU DEMAND FORECAST SCENARIOS.....	31
TABLE 3.4-2 - DOMESTIC SALES ELASTICITY.....	33
TABLE 3.4-3 - COMMERCIAL SALES ELASTICITY.....	33
TABLE 3.4-4 - INDUSTRIAL SALES ELASTICITY.....	34
TABLE 3.5-1 - DIFFERENCES BETWEEN EEPKO MEDIUM SCENARIO AND LOW SCENARIO.....	36
TABLE 4.2-1 - VOLUME OF EXPORT TO DJIBOUTI (GWH ET MW).....	40
TABLE4.2-2 - EXPORT SCENARIO CONSIDERED IN THE STUDY.....	41
TABLE 5.1-1 - IDO PRICE IN 2015.....	42
TABLE 5.1-2 - LRFO PRICE IN 2015.....	43
TABLE 6.1-1 - DIESEL CANDIDATE CHARACTERISTICS.....	45
TABLE 6.1-2 - COMBUSTION TURBINE CANDIDATE CHARACTERISTICS.....	46
TABLE 6.1-3 - COMBINED CYCLE CANDIDATE CHARACTERISTICS.....	47
TABLE 6.1-4 - SCREENING CURVE FOR THERMAL CANDIDATES IN 2015.....	48
TABLE 6.2-1 - HYDRO POTENTIAL IN ETHIOPIA (PER RIVER BASIN).....	49
TABLE 6.2-2 - FILLING TIME OF HPP PROJECTS.....	52
TABLE 6.2-3 - HALELE HPP STAGE I CHARACTERISTICS.....	54
TABLE 6.2-4 - WORABESA HPP STAGE II CHARACTERISTICS.....	55
TABLE 6.2-5 - CHEMOGA-YEDA HPP STAGE I CHARACTERISTICS.....	57
TABLE 6.2-6 - CHEMOGA-YEDA II HPP STAGE 2 CHARACTERISTICS.....	58
TABLE 6.2-7 - ALELTU EAST HPP CHARACTERISTICS.....	59
TABLE 6.2-8 - ALELTU WEST HPP CHARACTERISTICS.....	61
TABLE 6.2-9 - BARO I HPP CHARACTERISTICS.....	63
TABLE 6.2-10 - BARO II HPP CHARACTERISTICS.....	64
TABLE 6.2-11 - GENJI HPP CHARACTERISTICS.....	65
TABLE 6.2-12 - GEBA I HPP CHARACTERISTICS.....	66
TABLE 6.2-13 - GEBA II HPP CHARACTERISTICS.....	67
TABLE 6.2-14 - GOJEB HPP CHARACTERISTICS.....	69
TABLE 6.2-15 - GENALE III HPP CHARACTERISTICS.....	71
TABLE 6.2-16 - GENALE VI HPP CHARACTERISTICS.....	72
TABLE 6.2-17 - AWASH IV HPP CHARACTERISTICS.....	73
TABLE 6.2-18 - KARADOBI HPP CHARACTERISTICS.....	74
TABLE 6.2-19 - MABIL HPP CHARACTERISTICS.....	76
TABLE 6.2-20 - MANDAYA HPP CHARACTERISTICS.....	77
TABLE 6.2-21 - BORDER HPP CHARACTERISTICS.....	78
TABLE 6.2-22 - SUMMARY LIST OF HYDRO POWER.....	80
TABLE 6.2-23 - SMALL HYDRO PLANTS PROJECTS.....	82
TABLE 6.3-1 - EPSEMPU GENERATION EXPANSION PLAN (JUNE 2006).....	96
TABLE 7-6.3-2 - EPSEMPU INVESTMENT SCHEDULE.....	97
TABLE 7-6.3-3 - POTENTIAL GENERATION RESOURCES.....	98
TABLE 6.3-1 - PROJECTED LINES FROM 2006 TO 2015.....	100
TABLE 6.3-2 - PLANNED TRANSMISSION LINE ADDITIONS.....	102
TABLE 6.3-3 - NEW SUBSTATIONS.....	104

LIST OF FIGURES

FIGURE 3.1-1 - EVOLUTION OF GDP PER SECTOR	17
FIGURE 3.1-2 - PAST EVOLUTION OF ICD GENERATION AND PEAK DEMAND	22
FIGURE 3.1-3 - HISTORICAL EVOLUTION OF SALES BY CONSUMER SECTORS	24
FIGURE 3.2-1 - NOVEMBER WORKING DAY HOURLY LOAD CURVE	27
FIGURE 3.2-2 - NOVEMBER WEEK END HOURLY LOAD CURVE.....	27
FIGURE 3.2-3 - EVOLUTION OF EVENING DAILY PEAK FROM 1996 TO 2006	28
FIGURE 3.2-4 - SEASONAL LOAD CHARACTERISTICS OF THE ETHIOPIAN ICS (2005/2006)	28
FIGURE 3.2-5 - ICS ANNUAL LOAD DURATION CURVE FROM 1996 TO 1999.....	29
FIGURE 3.2-6 - ICS ANNUAL LOAD DURATION CURVE FOR 2005 AND 2006.....	30
FIGURE 3.4-1 - EEPKO TARGET AND MODERATE DEMAND FORECASTS	35
FIGURE 3.6-1 - DEMAND FORECAST: TARGET, MODERATE AND MEDIUM SCENARIOS.....	37
FIGURE 6.2-1 - MAP OF HYDROLOGICAL BASINS.....	49
FIGURE 6.2-2 - HYDROPOWER PROJECT LOCATIONS.....	51
FIGURE 6.2-3 - SCHEMATIC CONFIGURATION OF ABAY RIVER SYSTEM.....	83
FIGURE 6.2-4 - ZOOM FINCHA AMERTI NESHE	84
FIGURE 6.2-5 - ZOOM ALELTU	85
FIGURE 6.2-6 - SCHEMATIC CONFIGURATION OF WABE SHEBELE RIVER SYSTEM	86
FIGURE 6.2-7 - SCHEMATIC CONFIGURATION OF BARO RIVER SYSTEM.....	87
FIGURE 6.2-8 - SCHEMATIC CONFIGURATION OF ZOOM AWASH RIVER SYSTEM	88
FIGURE 6.2-9 - SCHEMATIC CONFIGURATION OF CHEMOGA YEDA SYSTEM.....	89
FIGURE 6.2-10 - SCHEMATIC CONFIGURATION OF OMO RIVER SYSTEM.....	90
FIGURE 6.2-11 - SCHEMATIC CONFIGURATION OF TEKEZE SYSTEM	91
FIGURE 6.3-1 - GEOTHERMAL PROSPECT AREAS WITHIN ETHIOPIAN RIFT VALLEY	94

LIST OF APPENDICES

1. Sheet Historic evolution of GDP
2. Sheet Historic sales, generation and peak demand
3. Sheet Monthly load duration curves
4. Sheet ICS forecast moderate scenario
5. Sheet SCS forecast moderate scenario
6. Sheet ICS forecast target scenario
7. Sheet SCS forecast target
8. Sheet ICS low target scenario
9. Sheet Low demand scenario
10. Sheet HHP Location

PHYSICAL UNITS And conversion factors

bbbl	barrel	(1t = 7.3 bbl)
cal	calorie	(1 cal = 4.1868 J)
Gcal	Giga calorie	
GWh	Gigawatt-hour	
h	hour	
km	kilometer	
km ²	square kilometer	
kW	kilo Watt	
kWh	kilo Watt hour	(1 kWh = 3.6 MJ)
MBtu	Million British Thermal Units	(= 1 055 MJ = 252 kCal)
	one cubic foot of natural gas produces approximately 1,000 BTU	
MJ	Million Joule	(= 0,948.10 ⁻³ MBtu = 238.8 kcal)
MW	Mega Watt	
m	meter	
m ³ /d	cubic meter per day	
mm	millimeter	
mm ³	million cubic meter	
Nm ³	Normal cubic meter, i.e. measured under normal conditions, i.e. 0°C and 1013 mbar	(1 Nm ³ = 1.057 m ³ measured under standard conditions, i.e. 15°C and 1013 mbar)
t	ton	
toe	tons of oil equivalent	
tcf	ton cubic feet	
°C	Degrees Celsius	

General Conversion Factors for Energy

To:	TJ	Gcal	Mtoe	MBtu	GWh
From:	multiply by:				
TJ	1	238.8	2.388 x 10 ⁻⁵	947.8	0.2778
Gcal	4.1868 x 10 ⁻³	1	10 ⁻⁷	3.968	1.163 x 10 ⁻³
Mtoe	4.1868 x 10 ⁴	10 ⁷	1	3.968 x 10 ⁷	11630
MBtu	1.0551 x 10 ⁻³	0.252	2.52 x 10 ⁻⁸	1	2.931 x 10 ⁻⁴
GWh	3.6	860	8.6 x 10 ⁻⁵	3412	1

ABBREVIATIONS AND ACRONYMS

ADB	African Development Bank
ADF	African Development Fund
CC	Combined Cycle
CCGT	Combined Cycle Gas Turbine
CIDA	Canadian International Development Agency
CT	Combustion Turbine
DANIDA	Danish Development Assistance
DFID	Department for International Development (UK)
DIDC	Department for International Development Cooperation (GoF)
DSA	Daily Subsistence Allowance
EEHC	Egyptian Electricity Holding Company
EEPCO	Ethiopian Electric Power Corporation
EHV	Extra High Voltage
EHVAC	Extra High Voltage Alternating Current
EIA	Environmental Impact Assessment
EIRR	Economic Internal Rate of Return
EN	Eastern Nile
ENCOM	Eastern Nile Council of Ministers
ENSAP	Eastern Nile Subsidiary Action Program
ENSAPT	Eastern Nile Subsidiary Action Program Team
ENTRO	Eastern Nile Technical Regional Office
ENTRO PCU	Eastern Nile Technical Regional Office Power Coordination Unit
FIRR	Financial Internal Rate of Return
GEP	Generation Expansion Plan
GTZ	German Technical Co-operation
HPP	Hydro Power Plant
HFO	Heavy fuel oil
HV	High Voltage
HVDC	High Voltage Direct Current
ICCON	International Consortium for Cooperation on the Nile
ICS	Interconnected System
IDEN	Integrated Development of the Eastern Nile
IDO	Industrial Diesel Oil
IMF	International Monetary Fund
JICA	Japanese International Co-operation Agency
JMP	Joint Multipurpose Project
LNG	Liquefied Natural Gas
LOLP	Loss of Load Probability
LPG	Liquefied Petroleum Gas

Module M3: Energy Sector Profile & Projections

VOL 3: ETHIOPIA

LRFO	Light Residuel Fuel Oil
MENA	Middle East, North Africa Countries
MIWR	Ministry of Irrigation & Water Resources (Sudan)
MWR	Ministry of Water Resources (Ethiopia)
MWRI	Ministry of Water Resources and Irrigation (Egypt)
MSD	Medium Speed Diesel (TPP)
NBI	Nile Basin Initiative
NEC	National Electricity Corporation (Sudan)
NELCOM	Nile Equatorial Lake Council of Ministers
NELSAP	Nile Equatorial Lake Subsidiary Action Program
NG	Natural Gas
NGO	Non Governmental Organization
NORAD	Norwegian Aid Development
NPV	Net Present Value
O&M	Operations and Maintenance
OCGT	Open Cycle Gas Turbine
OPEC	Organization of the Petroleum Exporting Countries
PBP	Pay Back Period
PHRD	Policy & Human Resource Development Fund
PIU	Project Implementation Unit
PRSP	Poverty Reduction Strategy Paper
RCC	Regional Electricity Control Centre (Egypt)
RE	Rural Electrification
SAPP	Southern Africa Power Pool
SIDA	Swedish International Development Agency
SSD	Slow speed diesel (TPP)
STPP	Steam Turbine Power Plant
STS	Senior Technical Specialist
TAF	Technical Assistant Fund
TPP	Thermal Power Plant
UA	Unit of Account
UNDP	United Nations Development Program
WB	World Bank

1. OVERVIEW

1.1 DEMAND FORECAST

The review of the demand forecast made by EEPSCO in the Ethiopian Power System Expansion Master Plan Update (EPSEMPU 2006) proved that the methodology and forecast models used by EEPSCO are robust.

Considering the relatively high growth rates adopted in two EPSEMPU scenarios (target and moderate), the Consultant considered necessary to introduce a low scenario.

The following table presents the main characteristics of these scenarios:

Scenario	Definition	2015	2030	Energy growth rate 2005-2030
High	EEPSCO target scenario	12 704 GWh 2 544 MW	71 570 GWh 14 330 MW	14.3%
Reference	EEPSCO moderate scenario	9 823 GWh 1 967 MW	34 030 GWh 6 814 MW	10.9%
Low	scenario introduced by the Consultant	7 439 GWh 1 489 MW	27 701 GWh 5 506 MW	10.0%

Table 1.1-1 - Main characteristics of the three demand projections for Ethiopia

1.2 POWER TRADE OPPORTUNITIES

The interconnection line with Djibouti has been financed, the tender for construction is planned for January 2007.

The feasibility study of the interconnection line with Sudan is completed.

The Ethiopian and Kenyan governments have signed a memorandum of understanding for the interconnection of the respective power systems. Currently the two countries have secured the finance to undertake the feasibility study. The most probable date for the realization of the interconnection is 2011 which coincides with the completion of the first phase of Gibe III. This power plant will have a capacity of 1 870 MW. The volume of exchange could range from 200 MW to 1 200 MW, which actually be determined from the result of the feasibility study. In addition in the long run the production from Genale Dawa project will supplement the export volume size.

The export scenario considered in the study is the following:

to	2008	2009	2010	2011	2015	2020	2025	2030
Djibouti (7000 h base load export)								
GWh	0	150	318	318	369	369	369	369
MW	0	21	45	47	53	53	53	53
Kenya (5000 h export)								
MW	0	0	0	200	400	600	900	1 200
GWh	0	0	0	1 000	2 000	3 000	4500	6 000
Sudan	0	0	200 MW max	200 MW max	Result of M6	Result of M6	Result of M6	Result of M6

Table 1.2-1 - Power export projection for Ethiopia

1.3 IDENTIFICATION OF GENERATION OPTIONS

1.3.1 THERMAL CANDIDATES

The candidate thermal plants identified are:

- 20 MW Medium Speed Diesel burning lowest grade of residual fuel oil,
- 70 MW Combustion Turbine burning diesel oil,
- 190 MW Combined Cycles burning diesel oil.

1.3.2 HYDROPOWER CANDIDATES

Ethiopia has abundant water resources and 122 km³ of water flow through 12 large and medium sized river basins. Approximately 85% of the water resources are in the western part of the country, in the major basins of Abay, Omo-Gibe and Baro-Akobo.

The corresponding economically exploitable potential is estimated to be about 30,000 MW (160 TWh) with 20,000 MW for the three major basins.

The following table presents the main characteristic of the hydro projects relevant for the present Study. The comparison and ranking of these projects will be carried out within Module 4:

Module M3: Energy Sector Profile & Projections

VOL 3: ETHIOPIA

Project name	Level of study (&date of study)	Installed capacity MW	Average energy GWh/year	Firm energy GWh/year	Project cost USD₀₆ M	Economic cost USD₀₆/MWh (discount rate 10%)	Economic cost USD₀₆/MWh (discount rate 12%)	Comments
Halele Worabesa	F (2000 & 2005)	420	510 + 1735	460 & 1570	232 & 275	60 & 21	73 & 26	financed project ?
Chemoga-Yeda	F (2005)	162 + 118		780 + 568	285 & 127	49 & 31	61 & 39	
Aleltu East	F (1995 ?)	186	800	780	438	77	95	
Aleltu West	PF (1994 ?)	265	1 050	983	560	76	93	
Baro I & II & Gengi	F (2005)	200 + 500 + 200	904 + 385 + 920	770 & 2 085	487, 350 & 139	78 & 20 & 22	95 & 25 & 27	
Geba I & II	F (2005)	215 + 157	935 + 853		295 & 124	45 & 19	55 & 23	multi purpose
Genale III & VI	F & PF (2006)	254 + 256	1 200 + 1 000	1 200 & 1 010	? & 383	34 & 50	40 & 60	possible HVDC link to Kenya
Karadobi	PF (2006) F (2007?)	1 600	8 600 (with BELES)	8 300 (with Beles)	2 231	40	50	+ 2.6 TWh downstream
Mabil	PF (?)	1 200	5 300					Incompatible with Mandaya
Mandaya	PF (2007)	2 000	12 100	11 200	2 477	29	36	Pre-feasibility studies carried out in Module 5
Border	PF (2007)	1 200	6 000 (wo Mandaya)	4000 (wo Mandaya)	1 442	34	42	Pre-feasibility studies carried out in Module 5
Gojeb	D (1997)	153	520	364	287	74	91	IPP ?
Awash IV	F (2006)	38	160	144	49	36	42	irrigation

Table 1.3-1- Main characteristics of the Ethiopian hydropower projects

1.3.3 OTHER TYPES OF POWER CANDIDATES

Opportunities in geothermal or wind projects exist in Ethiopia. However, considering the relatively low capacities involved (compared to large scale hydro projects) and the scope of the present Study, no development of geothermal or wind energy will be considered in the present Study.

1.4 REVIEW OF THE EXISTING GENERATION PLAN

Wind and geothermal power is considered in the EEPSCO investment program (EPSEMPU June 2006) and the plants recommended between 2010 and 2015 are mainly the Tendaho geothermal plant (3/5 MW) after 2011 and the Wind Park (50 MW) after 2011.

For thermal and hydro power plants, the investment program is summarized as following:

Year	Plant	N° of units x Capacity	System Dependable capacity (MW)	ICS Peak Demand - Medium scenario (MW)	ICS Peak Demand - Target scenario (MW)	Margin ratio for Target Demand scenario
2008	GILGEL GIBE II	4 x 105	1 135			
2008	TEKEZE	4 x 75	1 435	826	900	59%
2009	BELES	4 x 105	1 855	967	1 079	72%
2010	YAYU COAL	2 X 50	1 955	1 125	1 286	52%
2011	GIBE III (Phase 1)	4 x 226	2 857	1 266	1 485	92%
2012	GIBE III (Phase 2)	4 x 226	3 759	1 418	1 705	120%
2013						
2014	HALELE WORABESA	2 x 48,5 + 4 x 81,5	4 181	1 765	2 229	88%
2015	CHEMOGA YEDA	2 x 81 + 2 x 59	4 461	1 967	2 544	75%

Table 1.4-1- Ethiopian Generation Expansion plan to year 2015

It can be noticed that the system dependable capacity is significantly greater than the target peak demand projection which results in good opportunities for power exports to neighbouring countries.

The generation plan would also incorporate in long term other hydro power plants such as Geba, Genale, Baro, Gilgel Gibe IV, Awash IV, Karadobi, Gojeb, Aleltu, Mandaya and Border.

1.5 REVIEW OF THE TRANSMISSION MASTER PLAN

The master plan provided a detailed planning of new equipments up to 2015. The planned elements over the next 9 years will double the total length of the HV network, due to the extension of the HV network to supply rural areas, and the connection of new hydro plants to face the demand increase. A new voltage level - 400 kV - is to be commissioned within the next couple of years, for the evacuation of the generation of new plants (Gilgel Gibe II - 420 MW in 2008, Beles - 420 MW in 2009, Gibe III – 1 800 MW in 2011 and 2012). Interconnection projects are also mentioned. The hydro candidates, Border and Mandaya, are not included in the master plan. The power injection of such plants will impact the network development.

2. ORGANISATION OF THE REPORT

Module 3 deals with the future evolution of the demand and identification of supply and interconnection options. The findings of this Module will constitute the base on which the regional investment plan will be determinate.

This Module is organized in five Volumes:

- Volume 1: Executive summary of Module M3
- Volume 2: Energy Sector Profile & Projections for Egypt
 - Review and update of previous demand forecast.
 - Potential trade opportunities.
 - Review of the existing Generation Expansion Plan.
 - Identification of generation supply options.
 - Review of existing transmission master plan.
- Volume 3: Energy Sector Profile & Projections for Ethiopia
 - Review and update of previous demand forecast.
 - Potential trade opportunities.
 - Review of the existing Generation Expansion Plan.
 - Identification of generation supply options.
 - Review of existing transmission master plan.
- Volume 4: Energy Sector Profile & Projections for Sudan
 - Review and update of previous demand forecast.
 - Potential trade opportunities.
 - Review of the existing Generation Expansion Plan.
 - Identification of generation supply options.
 - Review of existing transmission master plan.

➤ Volume 5:

- Fuel prices Projections.
- Interconnection options.
- First evaluation of economic profitability of exports from Sudan-Ethiopia.

The present Volume 3 is focussed on the Energy and Sector Profile & Projections in Ethiopia.

3. REVIEW AND UPDATE OF DEMAND FORECAST

The review and update of the demand forecast is organized along the following items:

- Review of the past evolution of demand (energy and annual peak demand, by economic sectors, correlation with the GDP growth rate, demographic evolution, etc).
- Identification of demand characteristics (load factor, daily and seasonal variations and demand diversities, annual load duration curve).
- Review of the existing consumptions patterns and tariff.
- Review and update of the more recent demand forecast available.

3.1 REVIEW OF DEMAND PAST EVOLUTION

3.1.1 BACKGROUND

3.1.1.1 Development in demography

The most recent published national population and housing census for Ethiopia is based on surveys held in May 1994. At that time the total population was estimated at 61.7 million. Based on statistics from the Central Statistical Authority (CSA), the total population for 2006 was projected to be 75 million, with an average annual growth rate of 2.95%. Over 85% of this population is classified as rural. In contrast, at the 1984 census some 90% of the population was classified as rural. Based on 2002 estimates, the overall urban growth rate is 4.3%; however, this growth does not appear to be centered in Addis Ababa. The Addis growth rate, at 2.97%, is nearly 1.5 percentage points less than the overall average. Growth in the outlying urban centers is therefore estimated at some 4.9% per year.

At the overall growth rate of 2.9%, the population of Ethiopia can be expected to double in 25 years. This high growth is the result of one of the highest fertility rates in Africa at an average of 7.5 children per woman, equal to a crude birth rate of 47.3 per 1 000 population. The population growth rate would be even higher were it not for the high mortality rates for infants, children and mothers. The infant mortality rate is currently 139 per 1 000 population, also one of the highest rates in the world. Even with an effective population program, Ethiopia's population is expected to reach 135 million by the year 2025.

3.1.1.2 Characteristics of the Ethiopian Economy

The Ethiopian economy is predominantly agricultural. In 2005 this sector accounted for approximately 44% of GDP, generating approximately 85% of the total employment and contributing approximately 90% of total export earnings.

The industrial sector which is dominated by medium and large scale public enterprises accounted for approximately 11% of GDP. Industrial production is heavily dependent on imports of capital goods, semi-processed goods, raw materials, spares and fuel, thus making the sector highly vulnerable to foreign exchange fluctuations.

The service sector accounts for approximately 45% of GDP, with transport and trade playing an important role both in earning foreign exchange and in internal circulation of goods and passengers. The share of the service sector has been increasing slowly since the early 1980s, while the shares of industry and agriculture have declined.

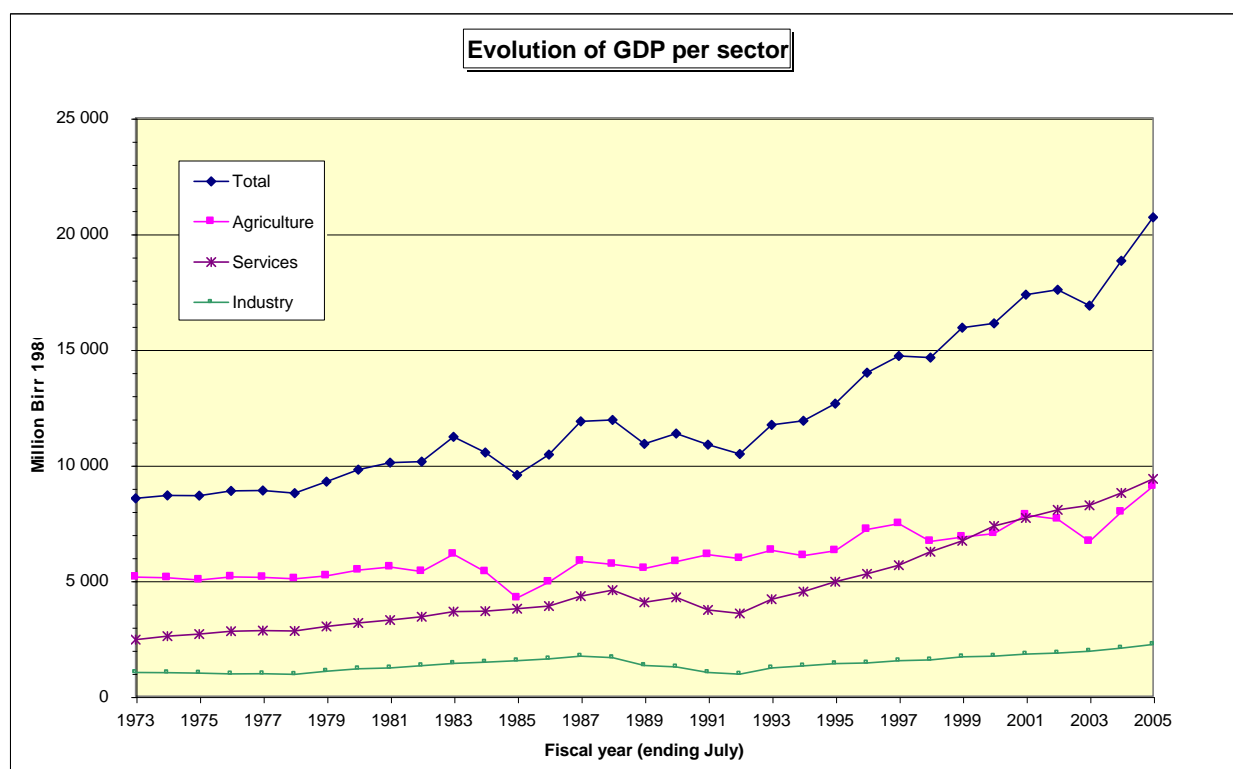

Figure 3.1-1 - Evolution of GDP per sector

As can be seen from the above Figure (see also Appendix Vol3-3 Table 1) presenting the historic evolution of GDP, economic performance has been deteriorating since the second half of the 1980's. Real growth rate declined sharply from 14% in 1987 to 0% in 1988 and further to negative growth rates in early 1990s.

From 1995 onwards, the average economic growth is 5% per year. The years 1998 and 2003 growth performance were affected among other things by adverse exogenous factors such as war (1998) and severe fluctuations in weather conditions (2003).

The last two years GDP growth of the country has significantly increased which is an average above 10% per year.

3.1.1.3 The Ethiopian Electric System

Ethiopia's electricity supply system is operated by the Ethiopian Electric Power Corporation (EEPCO). EEPCO is responsible for generation, transmission, distribution and sales of electricity nationwide. EEPCO operates two power supply systems namely the main interconnected system (ICS) and the main self-contained system (SCS).

The main interconnected system (ICS):

The main ICS, which serves the major towns and industrial centers, has a total installed capacity of 760.3 MW. This installed capacity is contributed by hydropower plants having a total installed capacity of 671 MW and thermal stations of about 89 MW (excluding small diesel stations). The thermal stations are stand-by diesel generators found at different places including emergency diesel units at Kaliti (14 MW), Awash town (35 MW) and Dire Dawa town (40 MW), which are required to mitigate the power shortage during seasonal influence on the hydro reservoirs. The Aluto-Langano geothermal station has an installed capacity of 7.3 MW, which is, at present, non-operational due to low pressure of the thermal fuels.

The self-contained system (SCS):

The SCS supplies isolated load centers, which are far from the ICS, mostly using diesel plants as a source of generation. Currently this system has an aggregate installed capacity of about 30 MW, of which 70%, ie. 23.8 MW are being generated from diesel stations. The remaining balance of 6.2 MW is being generated from small hydro power plants located at Sor, Yadot and Dembi.

EEPCO currently provides electricity to a total of about 1,200,000 customers in approximately 900 towns and communities in Ethiopia, which is only a small proportion of the country as compared to the total population estimated about 75 million. According to current estimates only about 17% of the population have access to electricity and the per capita electricity consumption is about 28 kWh, which is the lowest figure in world standard. Out of the total number of customers 95% are supplied from the ICS and the remaining 5% are within the SCS.

3.1.2 TARIFF STRUCTURES AND METERING TECHNOLOGY

Tariff structure:

The current tariff structure consists of six consumption categories:

- The domestic and general (commercial) categories are block tariffs with rates increasing with higher levels of consumption.
- The low and high voltage industrial categories are charged on a time-of-day basis with the high voltage charged at two voltage levels.
- The street lighting tariff is charged as a simple flat rate.

All categories include both a monthly service charge plus a per unit energy charge.

Evolution of tariff rates:

Until 1994, electricity tariffs increases in Ethiopia can be characterized as both infrequent and dramatic. From the 1952 tariff amendment until 1994 there had been only four revisions (1964, 1971, 1978 and 1986) although percentage increases had been as high as 54%.

The 1994 change was the first of a five-year package of tariff adjustments intended to increase the average tariff to US\$0.06 per kWh based on IMF requirements. The increase was to occur in three steps of 20, 35 and 45%. The revision was also to remove the existing cross-subsidy to domestic customers:

- The first change, which came into effect in October 1994 raised rates by an average of 12.7% from 0.2 Birr per kWh to 0.2254 Birr. At the time of the revision this was equivalent to US\$0.0376 per kWh (at 6.0 Birr per US\$).
- The second revision was originally scheduled to take effect some 20 months after the first revision. In this revision tariffs were adjusted to account for a revaluation of the assets, the effect of inflation and devaluation and the required level of self-financing ratios.
- Finally in April 1997 the tariffs were raised by 39.35% from an average of Birr 0.2254 per kWh to Birr 0.3141 (US\$0.0477 at 6.58 Birr per US\$). The third increment was implemented in April 1998 which raised rates by 32.5% to achieve the US\$0.06 per kWh plateau. The average tariff in April 1998 was Birr 0.4163 and the conversion rate 6.939 Birr per US\$.

The real price of electricity has been decreasing because of absence of frequent adjustments which takes care of inflation and exchange rate changes. After eight years, EEPSCO has once again adjusted its tariff by 22% in order to bring the real price back to US\$0.06 per kWh. The increment affects all categories of customers except the domestic first block (life line tariff). This adjustment is effective starting on July 2006.

In addition to the adjustment of the individual tariff rates the earlier tariff revisions have also involved changes to the tariff structure. Effectively, at each revision there have been customers moved from one category to another, for example:

- In 1986, many customers were moved between the commercial and the domestic categories, while others 'migrated' to the domestic category to take advantage of the cross-subsidy;
- The 1994 revision moved all schools, mosques, churches and utilities (both water and telephone) from the commercial category to the domestic tariff;
- In 1994, the small industrial category was eliminated and most customers transferred to the LV Industrial category;
- In addition, the definitions of LV and HV Industrial were revised to more clearly define these two categories on the basis of service voltage rather than power demanded;
- Also in 1994, the LV and HV industrial categories were converted to time-of-day tariffs;
- In 1997, the special boiler tariff was eliminated and all customers transferred to the HV Industrial category. The HV category was also split between 15 and 132 kV supply.

Recent tariff history is summarized in Table 1 below. Unless otherwise noted, all rates are expressed as Birr per kiloWatt-hour and in terms of the current tariff categories.

Module M3: Energy Sector Profile & Projections

VOL 3: ETHIOPIA

Category and Block	Mar. 14, 1986*	Oct. 11, 1994	Apr. 9, 1997	Apr. 9, 1998	July 06, 2006
Domestic					
0 – 50	0.1700	0.1540	0.2109	0.2730	0.273
51 – 100	0.1200	0.1600	0.2235	0.2921	0.3564
101 – 200	-	0.1819	0.2930	0.4093	0.4993
201 – 300	-	0.1873	0.3165	0.4508	0.5500
301 – 400	-	0.1917	0.3255	0.4644	0.5666
401 – 500	-	0.1973	0.3371	0.4820	0.5880
501 +	-	0.2113	0.3657	0.5691	0.6943
<i>Equiv. Flat Rate</i>	<i>0.1500</i>	<i>0.1772</i>	<i>0.2809</i>	<i>0.3897</i>	<i>0.4735</i>
<i>(US\$/kWh)</i>	<i>0.0725</i>	<i>0.0295</i>	<i>0.0427</i>	<i>0.0562</i>	
General**					
0 – 25	-	0.3096	0.3890	0.4990	0.6088
26 – 50	-	0.3522	0.3890	0.4990	0.6088
51 – 100	-	0.3522	0.4443	0.5691	0.6943
101 – 1 000	-	0.3666	0.4443	0.5691	0.6943
1001 +	-	0.3727	0.4443	0.5691	0.6943
<i>Equiv. Flat Rate</i>	<i>0.3436</i>	<i>0.3653</i>	<i>0.4301</i>	<i>0.5511</i>	<i>0.6723</i>
<i>(US\$/kWh)</i>	<i>0.1660</i>	<i>0.0609</i>	<i>0.0654</i>	<i>0.0794</i>	
LV Industrial					
Peak	-	0.2842	0.4755	0.6087	0.7426
Off Peak	-	0.2407	0.3469	0.4455	0.5433
<i>Equiv. Flat Rate</i>	<i>0.2232</i>	<i>0.2563</i>	<i>0.3690</i>	<i>0.4736</i>	<i>0.5778</i>
<i>(US\$/kWh)</i>	<i>0.1078</i>	<i>0.0427</i>	<i>0.0561</i>	<i>0.0683</i>	
HV Industrial (15kV)					
Peak	-	0.2530	0.3243	0.4168	0.5085
Off Peak	-	0.2230	0.2499	0.3224	0.3933
<i>Equiv. Flat Rate</i>	<i>0.2029</i>	<i>0.2341</i>	<i>0.2597</i>	<i>0.3349</i>	<i>0.4086</i>
<i>(US\$/kWh)</i>	<i>0.0980</i>	<i>0.0390</i>	<i>0.0395</i>	<i>0.0483</i>	
HV Industrial (132kV)					
Peak	-	-	0.3017	0.3882	0.4736
Off Peak	-	-	0.2325	0.3003	0.3664
<i>Equiv. Flat Rate</i>	<i>-</i>	<i>-</i>	<i>0.2416</i>	<i>0.3119</i>	<i>0.3805</i>
<i>(US\$/kWh)</i>			<i>0.0367</i>	<i>0.0448</i>	
Street Lighting					
Flat Rate	0.3320	0.3333	0.3087	0.3970	0.4843
Average Tariff	0.2000	0.2254	0.3141	0.4163	0.543
<i>(US\$/kWh)</i>	<i>0.0966</i>	<i>0.0376</i>	<i>0.0477</i>	<i>0.0600</i>	<i>~0.06</i>
<i>(Birr/US\$)</i>	<i>2.07</i>	<i>6.0</i>	<i>6.58</i>	<i>6.939</i>	<i>8.9</i>

Table3.1-1 - Recent tariff history (birr/kWh)

* March 1986 tariff included a separate (and higher) schedule for SCS consumption.

** As of April 9, 1997, the general category was reduced to two blocks, 0 - 50 kWh and 51+

Metering:

Metering for domestic and small general customers currently is based on the conventional kilowatt-hour meters. The capital and O&M costs of metering are recovered from customers in the form of a service charge. EEPCO as a pilot project has installed about 1 000 pre-paid meters with the intention of reducing the revenue collection period and metering costs. There is a plan of expanding and replacing all the existing conventional meters with these meters in the future. This year alone more than 35 000 meters are planned to be replaced with pre-paid meters.

Large consumption customers, with a maximum demand of above 20 kW, are required to install maximum demand meters and reactive energy meters. These meters are used for monitoring liability for power factor and minimum charge penalty payments and there are large number of these relatively sophisticated meters in the system.

3.1.3 ANNUAL ENERGY AND PEAK DEMAND HISTORICAL EVOLUTION

3.1.3.1 Calendar & fiscal year, time zone

In order to be consistent with the analysis of the three countries, dates in this chapter refer to the Gregorian calendar (GC).

Ethiopian calendar:

The Ethiopian calendar, like the Julian calendar, is composed of 12 months with 30 days. 5 or 6 days are added each year. The first day of the year is on GC September 11th or 12th.

The Ethiopian calendar is seven and a half years behind the Gregorian calendar. Hence the 1998 year in Ethiopia is equivalent to 2005/2006 in the Gregorian calendar.

Ethiopian Fiscal Year:

The Ethiopian Fiscal Year (EFY) runs from Haamle 1 (approximately July, 7th) to 30 Sene (approximately July, 6th)

Time zone:

The time zone is GMT + 3 with no summer period.

3.1.3.2 ICS and SCS demand historical evolution

The following figure presents the historic evolution of ICS and SCS demand (see also Appendix Vol3-3 Table 2):

Module M3: Energy Sector Profile & Projections

VOL 3: ETHIOPIA

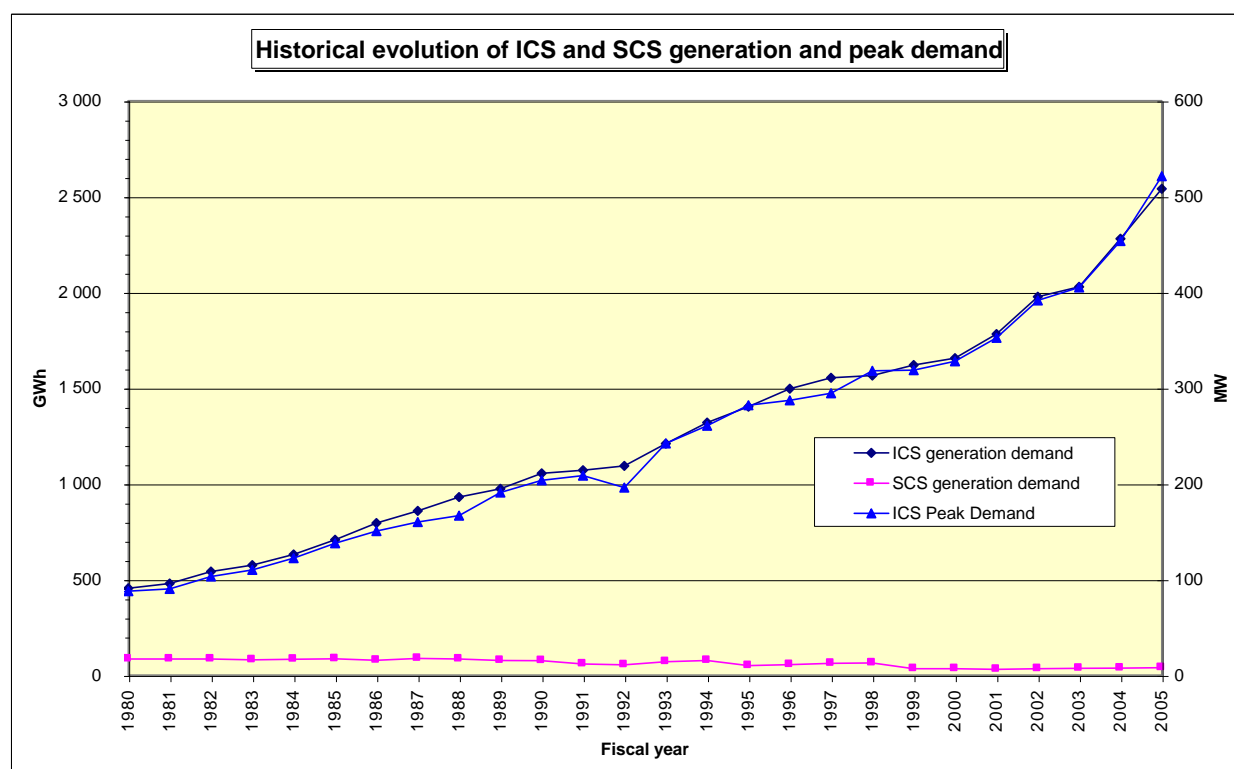

Figure 3.1-2 - Past evolution of ICD generation and peak demand

Note: In the previous figure, fiscal year 200n means calendar year 200n-1 to 200n.

EEPCO's ICS system peak and annual energy generation by 2006 has reached 587 MW and 2 845 GWh respectively. Due to the relatively stable load factor, peak demand and generation growth rate are close.

The SCS represents 1% of the total consumption of Ethiopia.

The following table shows that the annual growth rate of generation is about 1 point greater than the GDP growth rate. This is true on the average for the last 10 year period as well as the last two years. During the last 5 year period the average growth rate of demand was close to 9%, even in spite of the difficult 2003 economic year.

Period	Generation annual growth rate	GDP annual growth rate
1995-2005	5.9%	5.0%
2000-2005	8.8%	5.1%
2003-2005	11.8%	10.7%

Table3.1-2 - Comparison of GDP and generation annual growth rate

3.1.3.3 Historical evolution of sales

Since 1980 electricity sales in the ICS have increased at an average rate of 6.7% per year, with growth rates of above 7.5% in the 1980s, growth rates of 4.7% in the 1990s and with a much better growth from 2000 to 2006 averaging at 8.5% per year.

Within this large period of time (1980-2006) decline in the sales one year from the previous is observed only on years 1984 and 1999. Despite a moderate 5% increase in 2003 even with the presence of load shading, the recent ICS sales growth rate as indicated above averages to 8.5% per year. Taking out the 2002 data, the average growth rate for the years 2001 to 2006 is around 12% per year.

The average growth in the number of customer for the 80's was near to 7.8%, in the 90's it declines to around 5% and recently (2000-2006) it goes up again to 8.5%. The coincident rise and decline of the consumption and number of customers figures, for the periods considered, indicate that the increase in electricity sales have been driven largely by the increase in consumer numbers. Earlier the major increase in the number of customers has been the transfer of large SCS centers to the ICS, however, the recent increases are attributable to three factors. These are the ongoing high rate of rural electrification, the two to three year credits given on the initial connection fee and to a lesser extent EEPCO's customer service reform which enhanced EEPCO's capability in handling new customers.

The annual connection rate of consumers has dramatically risen from 40,000 in 1995 to 180,000 in 2006.

Patterns of consumption on the ICS have shown consistently higher growth in the residential, commercial and small industrial (before it was subsumed within the LV industrial sales) categories than in large industry. Based on 1990 data, nearly 45% of total sales are in the industrial category, comprised only of large industry and industrial electric boilers. This is to be compared with large industrial sales of over 60% of total in 1973. In 2005, 39% of total ICS consumption is in the industrial categories while about 35% and 25% of total sales are accounted for by domestic and commercial categories respectively. Recently, i.e. between the years 2000 and 2005 this pattern was stable except a slight (1.5%) increase in the commercial category and similar percentage point decrease in the domestic category.

In the following, the historical demands for electrical power by consumer group are described.

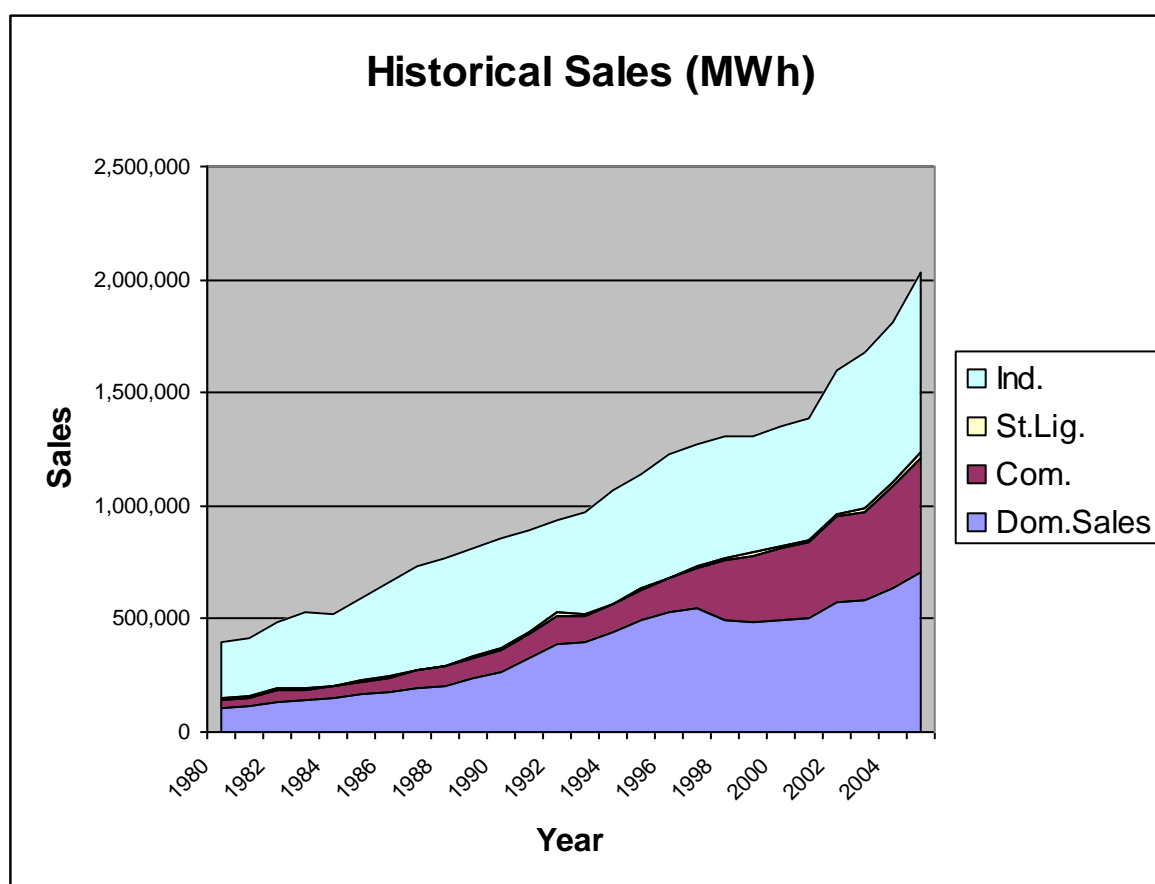

Figure 3.1-3 - Historical evolution of sales by consumer sectors

Currently consumption is mainly localized at major cities of the country. The main load center, Addis Ababa, alone currently takes about 49% of the total. The same figure for 1980 and 1990 were respectively 70% and 58%. This percentage is continually declining as more SCS centers transfer to ICS and newly electrified areas join the ICS from other parts of the country. Other major towns like Mekele, Nazareth, Bahar Dar and Dire Dawa constitute 18%, while the remaining branches take 33% of the 2005 total consumption. Regional distribution of the consumption is indicated in the following diagram.

3.1.3.4 Domestic Demand

As outlined above the domestic category takes 35% of the aggregate consumption. Since 1980, this category have steadily grown by an average of 8% per year. Approximately 82% of the growth has been due to new connections, and 18% to increased specific consumption per consumer. Specific consumption data from 1990 to 1997 indicated a steady rise of 4.3% a year, rising from 952 kWh to 1 325 kWh. During this period real tariffs rose only in 1994 and then by only 12%. The effect of the tariff increases in 1997 & 1998, the shadings on 2000 and 2003 and the ongoing higher rate of rural electrification have continually reduced the average consumption per customer to 953 kWh (2005) which is exactly that of the 1990 level. Within this period (1997-2005) the exception is the slight increase on 2002 (7.0%).

Earlier to avoid the initial connection fee low income house holds prefer to buy lighting power from meter lords. EEPCO targeting these customers started to give credit on the initial connection cost.

This is also one of the reasons for the observed high growth of customers in recent years and the reduction in specific consumption which was earlier inflated as one meter used to serve more than one customer.

A non-linear regression analysis performed in order to see the impact of income and price on domestic sales over various historical periods indicates that better correlation exists between total GDP and domestic sales rather than per capita GDP. Electricity is supplied to less than 6% of the households in the country, which are mainly in the middle and upper income group. Given the unequal distribution of income in Ethiopia these small group's income is more explained by the total economic activity rather than the per capita GDP.

Most of the regression analysis performed by taking various independent variables alone and in common did not come up with reasonable estimates. But an Analysis made for the 1990-2005 data serious show that the income (defined as total GDP) elasticity is around 0.35 and price elasticity is in the order of negative 0.4. This implies that a 10% growth in total GDP will result in a 3.5% growth in domestic electricity consumption. Similarly a 10% tariff increase leads to 4% decrease in electricity consumptions. This is a rather reasonable estimate when compared to other similar countries.

3.1.3.5 Commercial Demand

Consumers in the General tariff category comprise small businesses and commercial users. Commercial consumers represent 25% of electricity consumers and account for 12% of total sales.

Electricity sales to commercial customers grew by 10.7% on average from 1980 to 2005, but growth rates fluctuated widely from year to year, ranging between 49% in 1999 and -7% in 1993. The high growth in 1999 is associated with tariff structure changes which moved public institutions like schools, churches etc back to the commercial category. Because of the high growth this category continually registered, commercial consumption proportion from the total has raised from 10% in 1980 to 25% in 2005. Consumer number grew at a pace a little bit lower than total sales (9% per year on average) indicating that there is an average growth in specific consumption amounting to 2%. Since 1980 the number of commercial consumers has increased nine-fold to 104,000 in 2005.

Commercial electricity consumption is generally affected by general economic activity and, to a smaller extent, by the electricity tariff. In the case of Ethiopia where there is a rapid expansion of the ICS both to engulf the self contained system and to provide electricity to the rural villages, consumption will highly depend on the number of customers. It was not possible to find a definitive result from the regression analysis performed but in other similar countries this category is more responsive to the variation of economic growth indicators and less responsive to price variations than that of the domestic category.

3.1.3.6 Street Lighting

Sales record of street lights is somehow volatile. It is municipal owned and readings were not taken or reported appropriately. It accounts for less than 1.4% of total electricity sales in the ICS. Both number of customers and consumption has increased tremendously in recent years. Between 2001 and 2005 consumption has almost tripled to 28 GWh, while the number of customers

increased from 900 to 1 500. This rapid growth in recent years is mostly associated with the high rate of rural electrification that the country is currently undertaking.

3.1.3.7 Industrial Demand

Industrial consumers account for 39% of total electricity sales. This category comprises of a wide range of business enterprises ranging from flour mills, garages and workshops to relatively large-scale manufacturers and processors.

Total industrial sales grew at an average of 4.6% per year from 1980 to 2005. The highest average growth rate (8.5%) is registered in the period 2000-2005. Growth in the 80's was around 6.5% while in the 90's it was around 1%. Total sales even decreased in the early and late 1990s, reflecting the decline in industrial activity. In this period growth in industrial consumption was lower than those of domestic and commercial consumers; this may be due to the fact that industrial consumers were more strongly affected by supply constraints. Regression analysis performed to see the interdependence of the category with the growth in GDP shows that it has a better response to growth in economic activity than the other categories. The reasonable elasticity estimates are near to one or a little bit higher than one. The analysis further indicated that unlike the other categories the industrial consumption is not dependent on changes in price of electricity and number of customers. This result is reasonable as the cost of electricity generally represents only a fraction of total industrial production cost and therefore the customer is not sensitive to changes in price. Since the type of industries and also their specific consumption varies widely, this category is again less related to the changes in number of customers.

3.2 DEMAND VARIATION PATTERN

EEPCO has no load dispatch center and therefore automatic load data recording is not currently available. This type of data are collected manually through telephone communication with operators in generation stations. Manually collected twenty four hours demand data for the 365 days are available for years 1996, 1997, 1998 and 1999. For recent years only twelve hours data starting at 8:00 PM and ending at 8:00 AM are available. Records for some of the months are also missing. The analysis on the load pattern are therefore based on the available data.

3.2.1 DAILY LOAD VARIATION

Hourly generation data for the above mentioned years were reviewed to determine the pattern of the daily load curve for typical weekdays and weekends. Average curves for each month from 1996 to 1999 were included in the analysis. The typical load patterns show two distinct peaks, a morning peak at approximately 11 o'clock and a higher evening peak at 8 o'clock (units = MW):

Module M3: Energy Sector Profile & Projections

VOL 3: ETHIOPIA

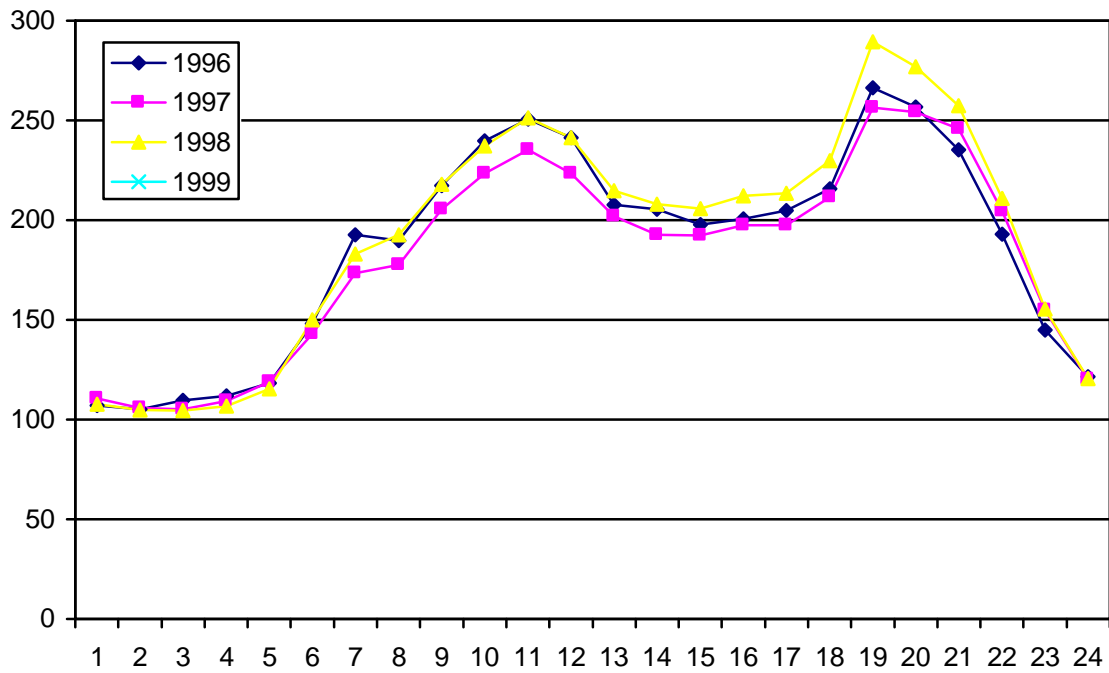

Figure 3.2-1 - November working day hourly load curve

The weekend daily patterns are neither significantly lower nor different than the weekday patterns:

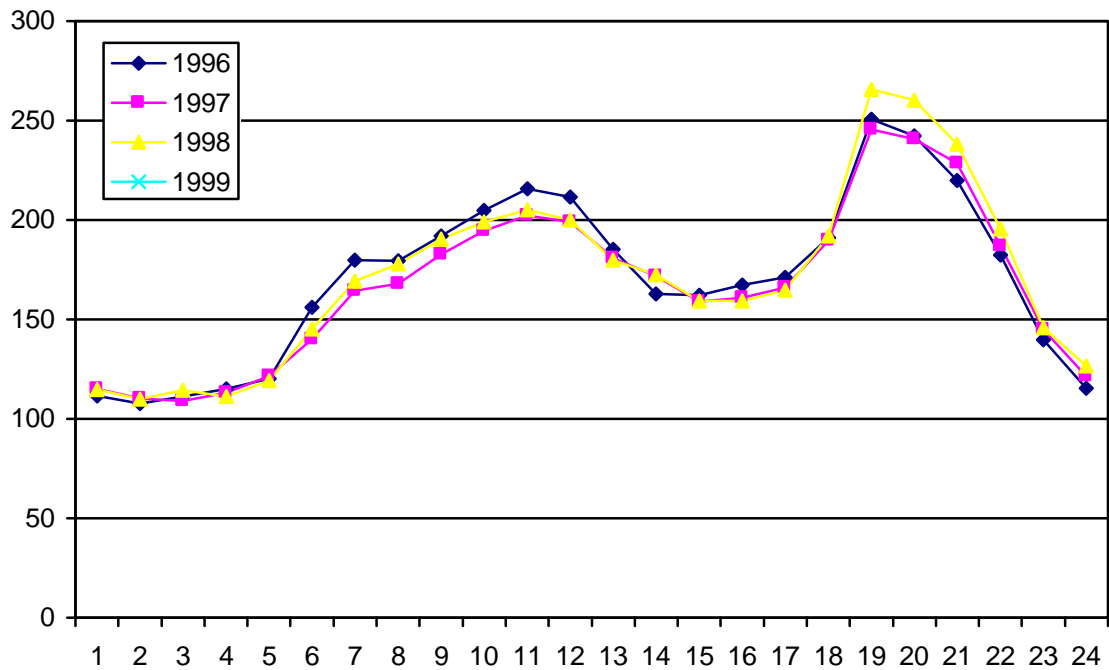

Figure 3.2-2 - November week end hourly load curve

This is compared with the recent data and the result is depicted in figure below. The three load curves are for a typical working day for years 1996, 2005 and 2006. As can be seen the gap between the morning and the evening peak has increased within this 10 years period:

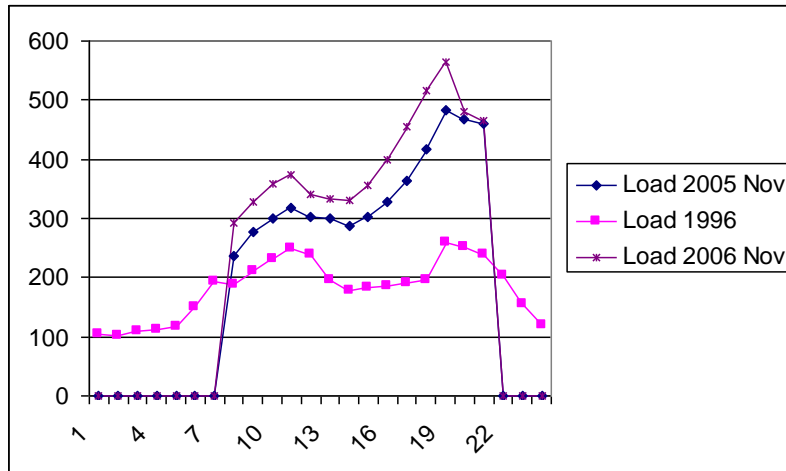

Figure 3.2-3 - Evolution of evening daily peak from 1996 to 2006

3.2.2 SEASONAL LOAD VARIATION

A key characteristic of the Ethiopian electricity demand is the absence of pronounced seasonal pattern due to the location of Ethiopia close to the equator.

Since electricity consumption of the agricultural sector is marginal, seasonal variations in agricultural activity have no impact on electricity demand. The existing industries do not have seasonal production and their demand is mostly similar in all months. Changes in temperature are moderate, so people are not accustomed to room conditioning.

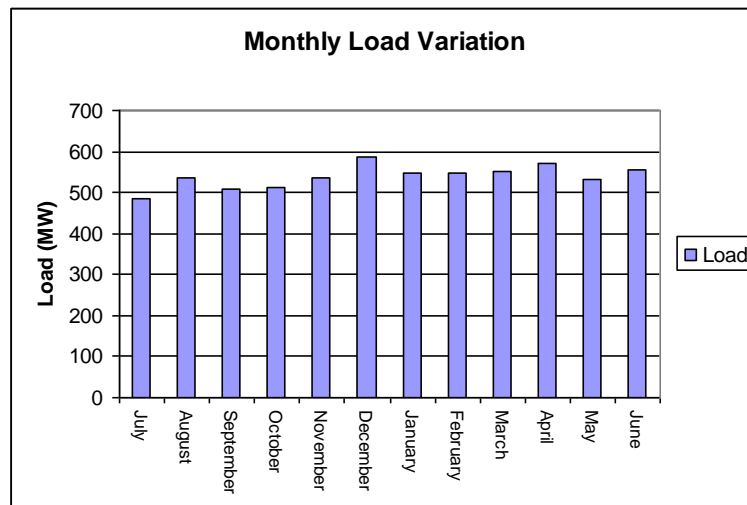

Figure 3.2-4 - Seasonal load characteristics of the Ethiopian ICS (2005/2006)

3.2.3 LOAD DURATION CURVE

The load data for 1996, 1997, 1998 and 1999 have been analyzed and used as a basis for the development of annual load duration curves. There is no significant monthly difference among these curves. The daily minimum on average is around 40% of the maximum demand while the yearly minimum value is around 30% of the peak demand. The monthly load duration curves are attached as Appendix Vol3-3 Fig 1.

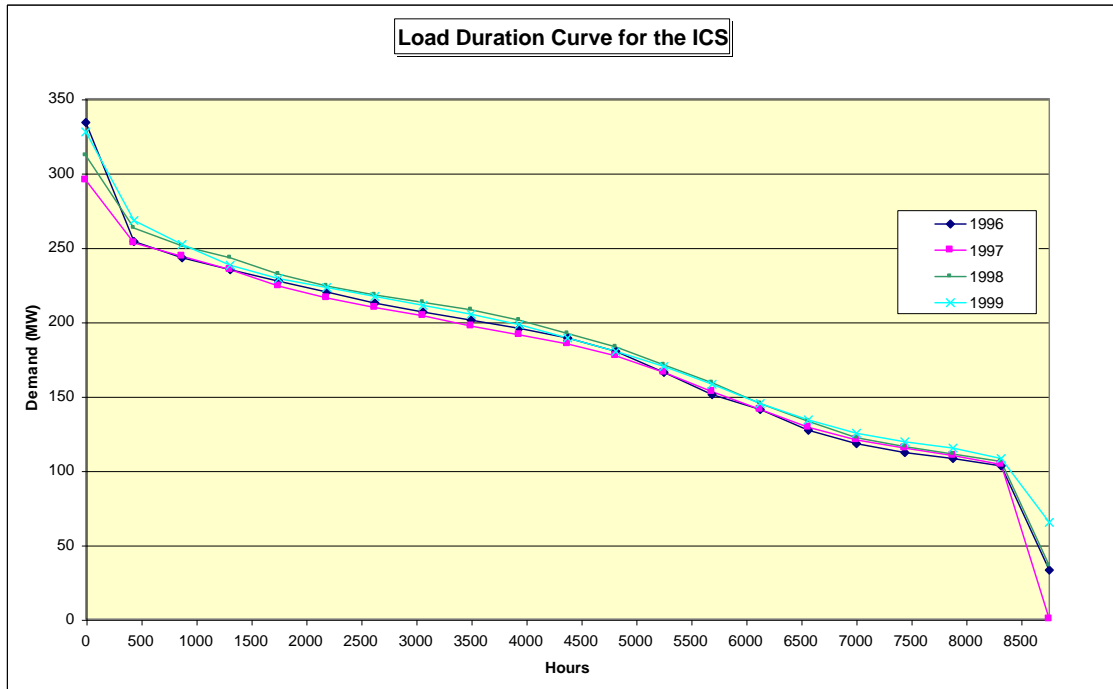

Figure 3.2-5 - ICS annual load duration curve from 1996 to 1999.

Load curve for 2005 and 2006 show the huge increase of power demand, around 80% from 1999 to 2006.

The peak hours slope is less steep than five years ago. The evening peak hours cover a longer period, growing from 6 pm to 8 pm. Lunch hours contribute also for a higher power demand.

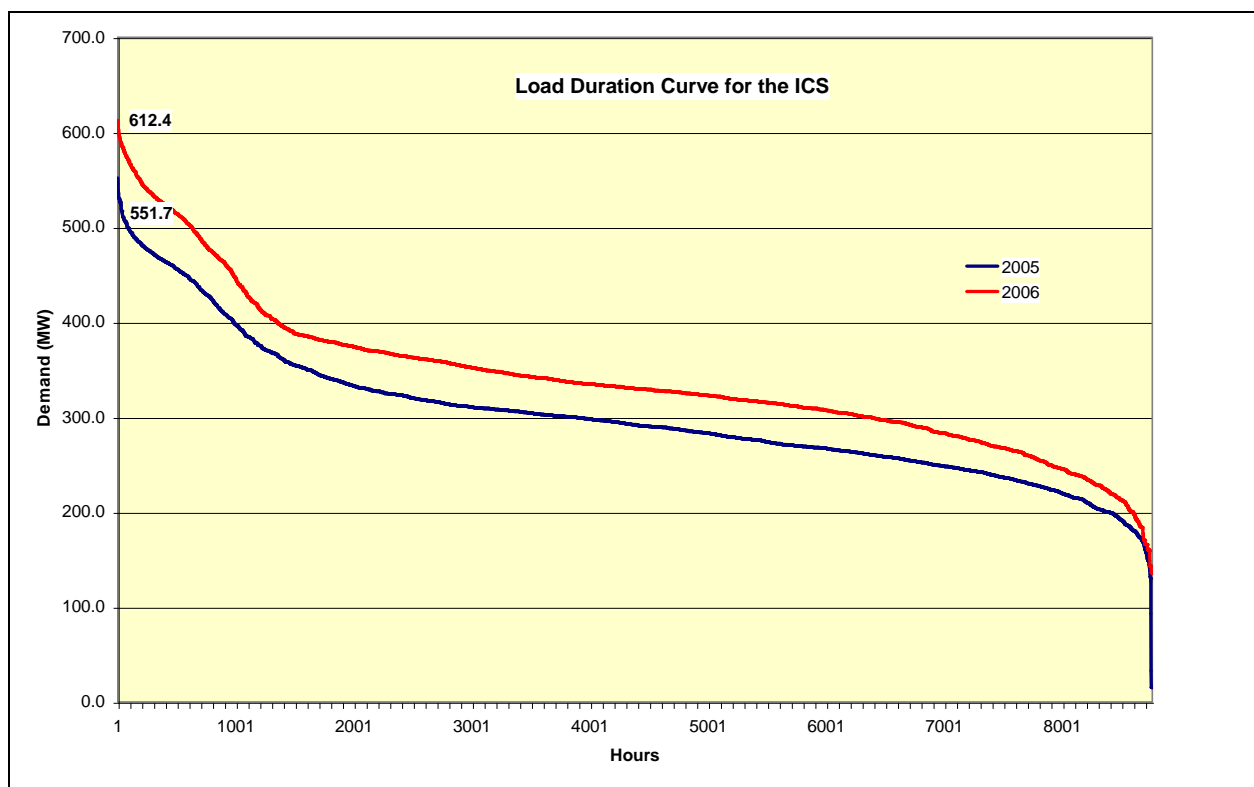

Figure 3.2-6 - ICS annual load duration curve for 2005 and 2006.

3.2.4 LOAD FACTOR

Generally speaking, a low load factor reflects a system heavily dominated by domestic loads, while a high value suggests either a system dominated by industrial sector consumption or demand suppressed by lack of generation capacity.

For most of the years the ICS load factor has been swinging in the range of 57% and 60% (see Appendix Vol3-3 Table 2). For the first time, after 1980 the load factor has declined to 55% in 2005 and 2006. In these two years, EEPCO has electrified more than 300 rural towns which normally are characterized with a much lower load factors. This has resulted in a reduced system load factor. The earlier years rise in the load factor and subsequent reductions are also associated with the bulk transfer of SCS centers to the interconnected system.

3.3 SYSTEM LOSSES

The ICS system loss varied within a limited range from 10% to 13% until mid 80s (see Appendix Vol3-3 Table 2). From this period to now the total loss vary in the range of 17% to 20%. The highest recorded peak is 22% in 2003. Variations in the loss figures are more attributable to sales data deficiency than any technical reasons.

System studies performed in the existing system of EEPCO indicate that transmission losses are in the range of 3.5 to 5%.

This indicates that the majority of losses are made up of distribution system losses and non-technical system losses such as metering errors, theft and fraud.

The loss in 2005 amounted to 20% of the generation. Definitive determination of losses at various voltage levels is not made until now, but the 2005 tariff study report indicates that medium voltage level losses amount to 3%, low voltage losses' including transformers to 6%. This will bring the total technical losses to 14%. The difference around 6% is that of the non-technical losses.

The ongoing rehabilitation and upgrading of the distribution system is expected to reduce the technical losses to around 10%. There is a wide room for improvement in the non-technical losses. Efforts are being made to modernize EEPSCO's billing system and these will have an impact on the reduction of the non-technical losses.

3.4 REVIEW OF EEPSCO DEMAND FORECAST

3.4.1 OVERVIEW

In 2006, EEPSCO updated the demand forecast of Ethiopia to form the basis of the 2006 Ethiopian Power System Expansion Master Plan Update (EPSEMPU – June 2006).

As such, much of the 2006 report and analysis draw heavily on the analysis contained in the previous Ethiopian Power System Expansion Master plan (EPSEMP) study report of Acres International of Canada. The 2006 update uses the sophisticated econometric model in the EPSMP Project

The two demand forecast were defined in the EPSEMPU:

Scenario	FY 2015	FY 2030	Average 2005-15	Average 2005-2030
Target	12 700 GWh	71 570 GWh	17.5%	14.3%
	2 544 MW	14 330 MW		
Moderate	9 823 GWh	34 030 GWh	14.5%	10.9%
	1 967 MW	6 814 MW		

Table 3.4-1 - EPSEMPU demand forecast scenarios.

The target scenario was considered in Scott-Wilson "Electricity Tariff Study" provided in 2006 to EEPSCO.

The be consistent with these studies, and considering the up to date and soundness of the econometric the Consultant will use the same scenarios for the Eastern Nile Power Trade Program Study.

The following paragraphs describes the main characteristic of the econometric model.

3.4.2 METHODOLOGY

The main differences between the 2006 update (EPSEMPU) and the 2000 study (EPSEMP) is the assumptions on:

- the future potential number of customer connection and economic growth rates,
- the availability of an additional 6 years of statistical data because of the elapsed time between the time when Acres undertook the regression analysis (start of 2000), and the time of the EPSEMPU (2006).

There are effectively 3 sub-forecasts contained in the overall updated load forecast of EEPSCO:

- Interconnected System (ICS) forecast,
- Self-contained system (SCS) forecast,
- Rural electrification forecast.

The forecast update has been started with an update of the forecast database in the econometric model developed by Acres, in order to incorporate all the available new relevant data set by branch (smallest administrative unit in EEPSCO) and tariff category. These include historical data on electricity sales by tariff category, tariff levels and data on measures of economic activity. The models present the relationship between electricity demand growth and electricity price in each tariff category and the level of economic activity.

The general relationships and elasticity determined in the econometric models were incorporated in a detailed branch-by-branch and substation-by-substation forecast of electricity consumption. Due to the difference in consumption pattern, three models which aggregate the different branches into three groups were developed for the ICS as described below:

- The first model (Model 1) relates to branches in the 'Base ICS' comprising the Addis Ababa Area, Nazareth, Dire Dawa and Harar. These branches have been electrified through the ICS for the entire period of record and have typically expanded within the bounds of each branch rather than through the addition of new branches.
- The second model (Model 2) relates to branches which were added to the ICS in the first major extensions to the system. These occurred in the early 1980s. The three extensions, comprising some 17 branches, are the Shashemene, Dessie and Southern Extensions.
- The final model (Model 3) addresses the remaining extension to the ICS.

SCS branches forecast is prepared based on trend analysis (constant growth of 7% per year).

Rural electrification forecasts are treated separately based on the Government electrification target of increasing the existing low rate of electrification in line with the Universal Electricity Access Program.

Consistent with the above classification the EEPSCO has prepared annual projections of power demand for a 25-year forecast period, from 2006 to 2030. For currently connected centres, the analysis has been based on an assessment of the demand within each principal power-consuming sector.

3.4.2.1 Income and price elasticity for the Interconnected System (ICS) demand

Elasticity coefficients link the sales with explanatory variables such as GDP and tariffs. The following values were considered in EPSEMPU 2006 study for the different sectors.

3.4.2.1.1 Domestic Sales Elasticity

Elasticity	Model 1	Model 2	Model 3
- Income	0.35	0.60	0.80
- Price	-0.40	-0.50	-0.6

Table 3.4-2 - Domestic Sales Elasticity

3.4.2.1.2 Commercial Sales Elasticity

Elasticity	Model 1	Model 2	Model 3
- Income	0.60	0.60	1.20
- Price	-0.20	-0.20	-0.35

Table 3.4-3 - Commercial Sales Elasticity

The general equation used to project Domestic and Commercial Sales is:

$$Sales(t) = Sales(t-1) \times CustGth \times \frac{GDP(t)}{GDP(t-1)} \times a \times \frac{Tariff(t)}{Tariff(t-1)} \times b$$

- where
- Sales = Commercial Sales in kWh,
 - Cust Gth = 1 + %Growth in the Number of Customers in year t,
 - GDP = Non-Agricultural Component of GDP,
 - Tariff = Commercial Tariff,
 - a = Income elasticity,
 - b = Price elasticity.

3.4.2.1.3 Industrial Sales Elasticity

Elasticity	Model 1	Model 2	Model 3
- Income	0.90	0.90	1.20

Table 3.4-4 - Industrial Sales Elasticity

The general equation used to project Industrial Sales is:

$$Sales(t) = Sales(t-1) \times \frac{GDP(t)}{GDP(t-1)} \times a$$

3.4.2.1.4 Review of the elasticity figures

Whilst reviewing the elasticity figures used in the derivation of the demand forecast for currently supplied areas, we have confirmed that the growth in specific consumption as indicated by the results of the forecast model, is in agreement with the expected growth rates as stated in the econometric modeling of the EPSEMPU report. This has given reassurance that the load forecast model is well constructed and that the results are robust.

3.4.2.2 Unsupplied centers

For currently unsupplied centers the forecasts were developed from estimates of population, population growth, the level of interconnection and consumption per connection. The forecast produces only an estimate of the level of consumption on the EEPKO grid system and each of its branches, as well as the consumption at each of the isolated branches.

3.4.3 EEPKO DEMAND FORECAST

The Forecast Model have a Database which consists of annual sales statistics by branch and tariff category from 1973 to 2005 as well as the available records of the number of customers at the end of each year over the same period.

The econometric relationships determined in the regression analysis were incorporated in a spreadsheet-based, sales-forecast model. These relationships provided the long-term growth trends for each of the principal tariff categories.

The sales forecast were combined with a projected loss rates to produce forecasts of energy generation and through the use of average load factors the capacity (MW) requirement to deliver the demanded energy is estimated.

Two sales forecasts (Target and moderate) have been prepared. The principal differences between the two forecasts are assumptions on the expected economic growth and level of new connection.

Moderate scenario:

This scenario is based on an annual non agricultural GDP growth rate of 8% p.a until 2030 (8% is the forecasted growth value for the 2006-2009 period by the Ministry Of Finance and Economic Development).

A target of 50% electricity access within 5 years is assumed.

Target scenario:

This scenario assumes that the priorities that the Government has given recently especially to the expansion of the basic infrastructures like electric power, water, road sector, etc, is expected to contribute a great deal to the swift development of the nation economic performance as a whole. Based on this, a 12% GDP growth until 2030 is assumed in this scenario.

A target of 50% electricity access within 5 years is assumed.

The figure below depicts the year 2006 Moderate and Target load forecasts of EEPSCO.

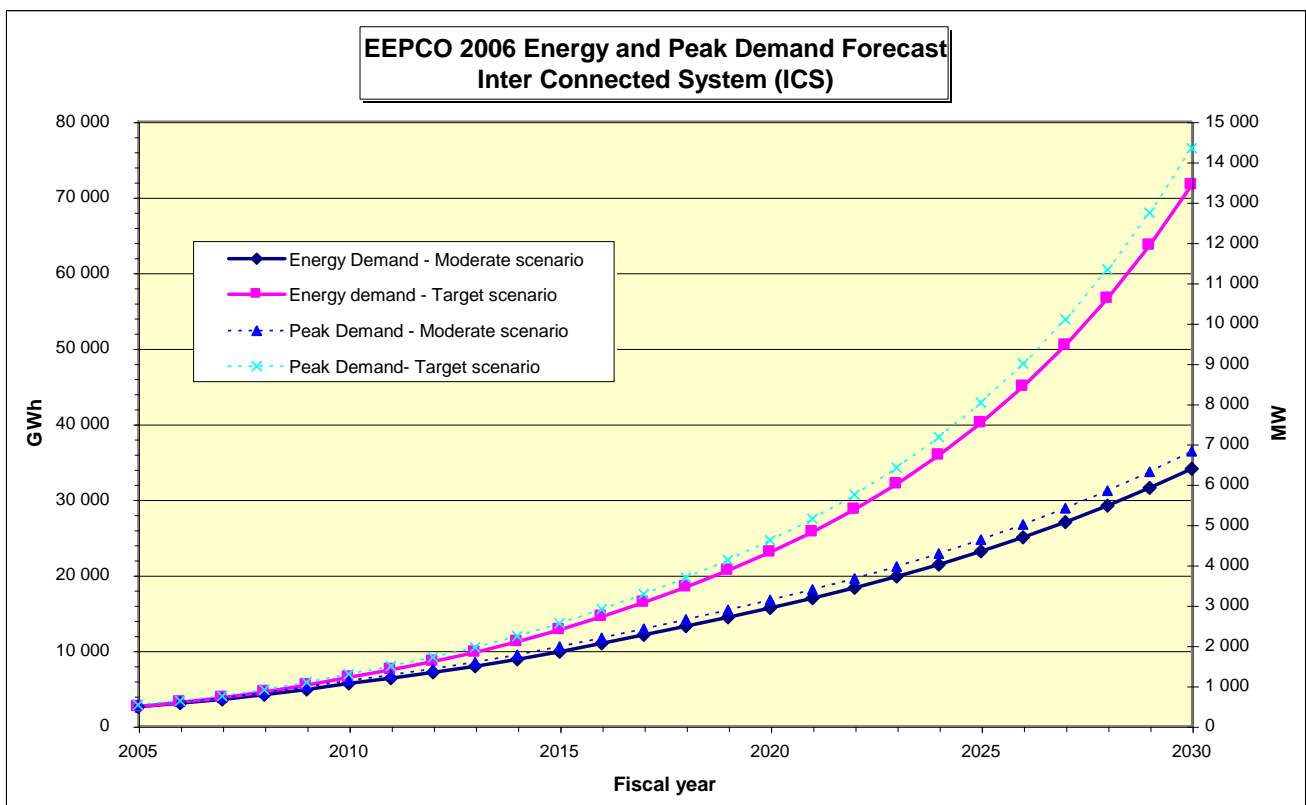

Figure 3.4-1 - EEPSCO target and moderate demand forecasts

Note: In the previous figure, fiscal year 200n means calendar year 200n-1 to 200n.

The average annual energy growth rate is 10.9% in the moderate scenario and 14.3% in the moderate scenario (see complete results in Appendix Vol3-3 Table 3 to 6).

For the ICS, the load factor is equal to 57% and the losses decrease to 15%.

Note: The SCS evolution is the same in both scenarios. Nevertheless, the SCS will not be considered in the present Study because it is not, by definition, connected to the main network which will be linked to the interconnection project.

3.4.4 CONSULTANT ANALYSIS

ICS:

Whilst the GDP rates (8%) employed in the Moderate forecast may be achievable we would question whether the GDP growth rates (12%) employed in the target load forecast are achievable for more than a few years, not to mention 25 years. Moreover the Consultant also has some doubts whether the 50% access expansion target, while desirable for the population, could be achieved within 5 years.

Accordingly the Consultant proposes to consider the target scenario as a high scenario, the moderate scenario as the reference scenario, and introduces a low scenario described in the next chapter.

SCS:

The SCS evolution is the same in both target and moderate scenarios. As stated above the SCS forecast is just based on trend analysis and projects the future need based on a constant growth rate of 7%. Looking at the historical trend the assumed growth rate is indeed realistic. Given the relatively insignificant size of the SCS in the context of the Ethiopian power system the results of the SCS forecast have little role in the planning of the Power system.

Finally, the SCS will not be considered in the present Study because it is not, by definition, connected to the main network which will be linked to the interconnection project.

3.5 LOW DEMAND FORECAST

The load forecast review undertaken in the sections above has indicated that the methodology and the forecast models used by EEPSCO are robust.

The same methodology is applied by the Consultant for the low scenario which differences from the EEPSCO medium scenario are listed in the table below:

Assumption	EEPSCO medium scenario	Low scenario
50% access to electricity	in 5 years	in 15 years
Tariffs	+16% (in 2007)	+25% (10% in 2008 and 2009, +5% in 2010)
Number of customers	+150 000 in 2006 +3% per year from 2018	+ 130 000 in 2006 +3% per year from 2018

Table 3.5-1 - Differences between EEPSCO medium scenario and low scenario

The detail of hypothesis is list in Appendix M3-3-Vol3-1.

3.6 DEMAND FORECAST SUMMARY

The following figure presents the generation and peak demand for the three scenarios:

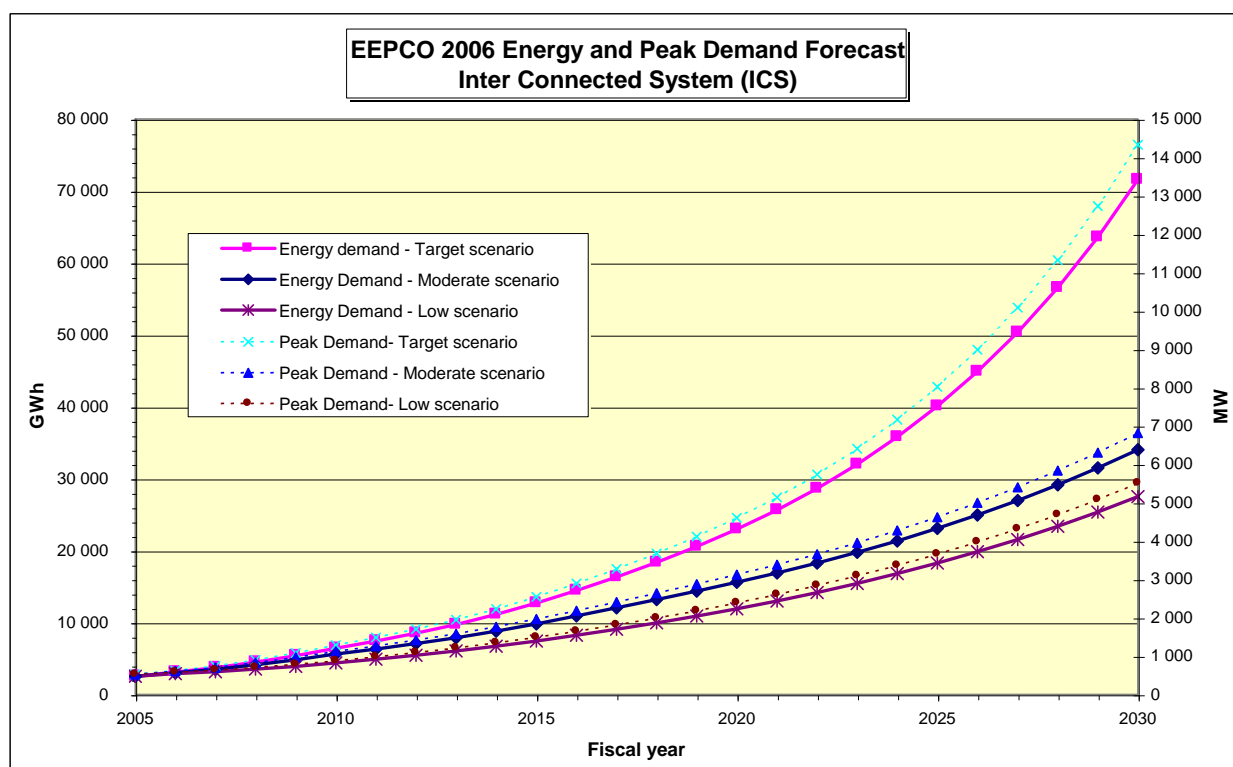

Figure 3.6-1 - Demand forecast: target, moderate and medium scenarios

Note: In the previous figure, fiscal year 200n means calendar year 200n-1 to 200n.

4. POTENTIAL TRADE OPPORTUNITIES

4.1 OVERVIEW

The purpose in this task is to identify the potential of power trades between, on one side, the area composed of Egypt, Ethiopia and Sudan, and on the other side, the neighbouring countries (Libya, Jordan, Djibouti, Kenya, etc).

Obviously, the potential evolution of power trades between Egypt, Ethiopia and Sudan, which is the core of the present study, will be the result of Module M6 (Investment Regional Planning).

4.2 POTENTIAL TRADE OPPORTUNITIES

4.2.1 GENERAL

There is an opportunity to focus the expansion of the Ethiopian power system on development of the renewable indigenous energy resources; primarily on the massive hydro resource which the nation is particularly endowed with, as this will going to be the best alternative to serve the regional demand for electricity as well in the coming future. The long-term generation expansion plan of Ethiopia could be tailored in line with such perspective, as it helps to reduce the neighboring countries reliance on hydrocarbon fuels and thermal based mode of generation, which is quite expensive, especially this time when the international oil price strikes peak. This is also in line with the clean development view of the Kyoto protocol. Under the Kyoto agreement such interconnection projects in which generation of electricity based on fossil fuels replaced with renewable hydro energy could be eligible for Clean Development Mechanism (CDM) subsidies.

Based on such opportunities and considerable hydro resource potential (about 30,000 MW/650TWh per year), Ethiopia envisages to practice cross-border power trade by developing the hydro-resources and having contractual agreements on export of power between the neighboring countries. The Ethiopian Power System, when expanded as planned, will have energy available that is surplus to Ethiopia's domestic needs. The surplus energy will vary through time, from higher values immediately after new generation is added. The surplus energy could provide an opportunity for export sales if there is a suitable market for it. The neighboring states of Sudan, Djibouti, Kenya, and Somalia could provide such markets if there happens conducive environment in the economic integration and cross-border trading with Ethiopia, in particular.

In this respect, the Government of Ethiopia (GoE) shall widen and deepen cooperation with the neighboring countries in the political, economic, and social fields for the mutual benefits of Eastern and Horn-African Countries in general through integrated development of their power system and HV interconnection facilities as well as sound power exchange agreements. It is only then that the big-sized hydropower developments in Ethiopia could be justified through the economy of scale needed, which enables Ethiopia to be interconnected with these countries to facilitate the purchase and sale of energy and to minimize the effects of local droughts (power shortages).

The following potential power trade opportunities between Ethiopia and neighboring systems have been identified in various previous studies:

- Sudan market,
- Kenya market,
- Uganda market,
- Egypt market,
- Djibouti market,
- Somali market,
- Eritrea market.

4.2.2 SUDAN MARKET

The Feasibility Study Update of the "Ethiopia-Sudan Power systems interconnection Project" was completed by Hifab Oy and SOGREAH Consultants in 2006 in conjunction with EEPCO and NEC Utilities.

In the feasibility study a number of routes were compared. The Metema(Shehedi)-Gadaref route is found to be the least cost option. The project is comprises of reinforcement of the existing B.Dar-Gonder single circuit line with a construction of another single circuit line, addition of a second circuit to the ongoing Gonder-Metema transmission project and construction of a double circuit 230 kV line from Metema to Gadarif.

The project is ready to go ahead as soon as financial backing is guaranteed.

The project's sponsors are in negotiation with the World Bank to finance the project in Ethiopia. The search for financiers in Sudan is still under way, even though Sudan has declared that it will fund the project using its own resources.

Considering the Feasibility study results and the funding still pending, the Consultant assumes that the commissioning date of the interconnection will be 2010.

The volume of exchange with Sudan depends on the amount of surplus in Ethiopia and the displaceable thermal generations in Sudan. Though the feasibility of the interconnection study had identified exchange volumes, the frequent updates of the generation expansion plan on both sides are expected to change these figures. Currently the size of the interconnection line has been decided to be 200 MW. The Module 6 study will indicate with definitive figures the exchange volume and capacity higher than 200 MW will be considered.

4.2.3 KENYAN MARKET

The transmission distance between these power systems is relatively long (800 to 900 km) and a high voltage direct current (HVDC) transmission is probably required. Benefits could be derived from net export of power from Ethiopia to Kenya, hydro complementarities and general power system advantage. The economic viability would depend on the amount of power exported to Kenya.

The Ethiopian and Kenyan governments have signed a memorandum of understanding to underpin plans for EEPCO to supply Kenya Power and Lighting Company and Kenya Electricity Generating Company with power to serve borders towns by end of 2007. The MoU was signed by Kenyan Energy Minister and Ethiopian counterpart.

Looking for the medium term, the Gibe II HPP is under construction and provided the interconnection line (400 kV) is built in 2011, this HPP could supply Nairobi.

Looking for the long term, one project could be to build an other hydropower plant on Genale Dawa river to supply Nairobi with additional power through the transmission line Ethiopia/Kenya.

At the date of the present report, no Feasibility study is available but the process is starting.

Being interconnected with the Kenyan grid, Ethiopia would have ample access to the South Africa Power Pool (SAPP) to trade electric power with the South African countries.

Considering the previous information, the Consultant assumes that the commissioning date of the interconnection will be 2011.

As the feasibility study is yet to begin there is no definitive figure on the volume of exchange. Currently the Kenyan generation is more than 1 000 MW and 6 500 GWh and will reach up to 2 500 MW and 14 839 GWh at around year 2015 as per their year 2005 predictions. According to the Kengen plan Kenya will introduce about 210 MW thermal generations up to year 2009 on top of the existing 284 MW capacity. With the growing demand and lesser cheap generation options more expansions in the future are expected to be through thermal generations. Kenya being a fuel importing country, the possibility for export of hydro generations in Ethiopia to Kenya is high.

The Consultant assumed that a 15% of total generation capacity will be imported from Ethiopia to Kenya. A higher figure should be unusual and unrealistic.

4.2.4 UGANDA MARKET

The transmission distance between these power systems is similar to the distance between Ethiopia and Kenya (800 to 900 km). As for Kenya, benefits could be derived from net export of power from Ethiopia to Uganda, hydro complementarities and general power system advantage. The economic viability would depend on the amount of power exported to Uganda.

No Feasibility study is available or financed. No recent progress have been found on this project.

Accordingly, the Consultant assumes no exchange between Ethiopia and Uganda.

4.2.5 EGYPTIAN MARKET

The potential and viability of power trade between Ethiopia and Egypt, which is the core of the present study, will be evaluated in Module 6 of the present Study.

4.2.6 DJIBOUTI MARKET

The power transmission between Ethiopia and Djibouti has been the subject of several studies. The length of the 230 kV transmission line is about 280 km with a capacity of 100 MW.

Since the projected demand in Djibouti is expected to grow from 55 MW to be below 120 MW until at least 2020, the interconnected capacity is unlikely to place a constraint on energy transfer over the study period.

The interconnection project is now financed. The tender for the construction is planned to be floated on January 31, 2007. The planned commissioning date is February, 2009

In line with the EPSEMPU June 2006, the Consultant assumes the following evolution of export energy and capacity (based on 7000 h load factor) to Djibouti:

Year	2008	2009	2010	2011	2012	2013	2014	from 2015
GWh	0	150	318	328	338	348	358	369
MW	0	21	45	47	48	50	51	53

Table 4.2-1 - Volume of export to Djibouti (GWh et MW)

4.2.7 SOMALI MARKET

The Somali market is very small with a potential of 50 to 100 MW.

A possible line route would be from Dire Dawa 230 kV substation, with a total transmission length in the range of 400 to 500 km.

The main problem is the current political situation in Somali which is not favorable for an interconnection project. Accordingly, the Consultant assumes no power exchange with Somalia.

4.2.8 ERITREA MARKET

The power system of Eritrea is totally thermal base with a potential of 50 to 100 MW.

A possible line route would be from Shire Inda Selasse Substation 230 kV substation, with a total transmission length of about 200 km.

The current political situation between Ethiopia and Eritrea is not be favorable for an interconnection project. Accordingly, the Consultant assumes no power exchange with Eritrea.

4.2.9 SUMMARY TABLE

The following table presents the export scenario hypothesis considered in the present Study:

to	2008	2009	2010	2011	2015	2020	2025	2030
Djibouti (7000 h base load export)								
GWh	0	150	318	318	369	369	369	369
MW	0	21	45	47	53	53	53	53
Kenya (5000 h export)								
MW	0	0	0	200	400	600	900	1 200
GWh	0	0	0	1 000	2 000	3 000	4500	6 000
Sudan	0	0	200 MW max	200 MW max	Result of M6	Result of M6	Result of M6	Result of M6

Table4.2-2 - Export scenario considered in the study

5. FUEL PRICES

Fuel resources for thermal generation consist of the traditional Imported Petroleum Fuels and potential undeveloped **Natural Gas** and **Coal** resources in Ethiopia.

5.1 PETROLEUM PRODUCTS

Petroleum fuels are imported into Ethiopia through the port of Djibouti (or the port of Asab in Eritrea) and transported by road to main centres in the country for electricity production. The nearest source of petroleum fuels available in Ethiopia is the Arabian Gulf. And the cost of the fuel delivered in to Ethiopian thermal plants was obtained by adding to the international price, the costs of port handling, local delivery and transport by road in Ethiopia.

At the present time there is no infrastructure in Ethiopia to transport the low cost heavier fuel oil (HFO) and it has therefore been assumed that two types of fuels could be used at present:

- Industrial Diesel Oil (IDO) for Combustion Turbines (CT) and Combined cycles (CC),
- Lowest Grade of Residual Fuel Oil (LRFO) for medium speed Diesel.

In 2006, the gas-oil price was 5.4 Birr/liter delivered by road to Addis Ababa and 5.2 Birr/liter to Dire Dawa.

The road distance between the port of Djibouti and Dire Dawa is 310 km (530 km to Awash and 830 km to Addis Ababa).

For EEPSCO, the 2006 fuel price in Dire Dawa from the port of Djibouti was:

- AGO; 5.21 Birr/liter,
- HFO; 3.88 Birr/liter,
- LFO ; 3.96 Birr/liter.

The price projections for IDO and LRFO to Dire Dawa in 2015 (2006 US dollars) are as follows according to the three average crude oil price scenarios (high, low and medium) given in Module 3 Vol 5 report (identical to the Annual Energy Outlook 2007 projections).

IDO price in 2015 (2006 US dollars):

IDO	Crude oil price	Dire Dawa	Awash	Addis Ababa
Low scenario	35 \$/bbl	9.4 \$/GJ		
Reference (medium)	50 \$/bbl	12.7 \$/GJ	+0.5 \$/GJ	+1.2 \$/GJ
High scenario	80 \$/bbl	19.1 \$/GJ		

Table 5.1-1 - IDO price in 2015

LRFO price in 2015 (2006 US dollars):

LRFO	Crude oil price	Dire Dawa	Awash	Addis Ababa
Low scenario	35 \$/bbl	6.3 \$/GJ		
Reference (medium)	50 \$/bbl	8,1 \$/GJ	+0,6 \$/GJ	+1,5 \$/GJ
High scenario	80 \$/bbl	11.9 \$/GJ		

Table 5.1-2 - LRFO price in 2015

Note: The rapid and substantial increase of the crude oil price over the past five years reduced the competitiveness of liquid-fired generation and discouraged investments in this sector.

With an average \$8.3 per Mbtu (\$50 /bbl) it becomes uneconomical to produce energy in base load from petroleum liquids when coal or gas is available. Nevertheless, in Ethiopia natural gas is not available for electricity generation and coal is limited.

5.2 COAL

Coal reserves exist in small quantities in the Delbi-Moye basin (and also at Achibo-Sombo?) situated about 350 km south west of Addis Ababa and 50 km south of Jimma, with a total coal deposit of 40 million tons and mineable surface reserves estimated at about 2 million tons.

A significant quantity of coal has been discovered at Yayu, for development of a 100 MW coal fired plant for about 35 years. The Government of Ethiopia has initially attributed exploitation of the Yayu mine and the development of a 2 x 50 MW power plant connected to the ICS to a Chinese company.

The development cost of the power plant and the Yayu coal mine was estimated at about 175 M\$.

The construction period for the Yayu coal complex was estimated to be about four years. Environmental impact assessment made by Lahmeyer International concluded that the project has significant impact and EEPCO has already decided to delay the project for some time in the future.

Yayu plant was committed for the year 2010.

For a 80% plant factor, the cost of generation (approximately 650 GWh per year) of the Yayu coal complex, calculated with a 12% discount, is estimated at 50 \$/MWh according to:

- a fixed annual cost of about \$250 /kW per year,
- and, a total variable cost of \$15 /MWh.

The Consultant assumed that due to the delay and environmental uncertainties, the project has not to be considered.

5.3 NATURAL GAS

Natural gas in exploitable quantities has been discovered in the Calub area in the south east of the country, close to the border with Somalia. The reserve is estimated at about 2.7TCF in two different horizons. The estimated reserves for electricity production will be sufficient for long-term moderate use, but not very economical if the length of the pipeline to main centres is over 700 km. Studies have demonstrated that the production costs will be too expensive in base load utilisation

because of the transport infrastructure to be developed. The gas price delivered to a gas-fired power plant in Dire Dawa is estimated to be about \$4 /Mbtu.

The government has decided not to use the Calub natural gas for electricity generation but for production of commercial fertilizer, liquefied natural gas (LNG), fuel for domestic consumption or compressed natural gas (CNG), etc.

Accordingly, natural will be considered not available for power generation in the present study.

6. GENERATION SUPPLY OPTIONS

The purpose of this section is to identify the potential generation candidates to be considered in Module 6 economic study. The ranking and screening of these candidates will be carried out in Module M4 (for large HPP) and Module 6 (for TPP).

6.1 TPP CANDIDATES

The candidate thermal plants recommended by EEPSCO in the January 2003 Ethiopian master plan study are:

- 20 MW Medium Speed Diesel burning lowest grade of residual fuel oil (LRFO),
- 70 MW Combustion Turbine burning diesel oil (IDO),
- 190 MW Combined Cycles burning diesel oil (IDO).

The following 3 tables set out the main parameters (cost and performance characteristics given in 2006 dollars at site conditions) for candidate thermal plants located at Dire Dawa (altitude 1 000 m, average temperature 30°C). The fuel price delivered to Dire Dawa is in accordance with the AEO2007 projections in 2015 with a crude oil price of 50\$ per barrel (Reference scenario).

Note: cost does not include emission penalties (CO₂, SO₂, etc.).

Module M3: Energy Sector Profile & Projections

VOL 3: ETHIOPIA

Parameters	unit	Medium Speed Diesel
Type of Fuel		LRFO
Capacity (ISO)	MW	20
Capacity (net)	MW net	17,4
Construction period	years	2 (60% & 40%)
Life span	years	20
Availability	%	78% (forced outage rate 8%)
Capital cost at site conditions	\$/kW net	1 120
Annuities	\$/kW /yr	159
O& M cost	\$/kW /yr	75
Total fixed capital cost	\$/kW /yr	253
Fuel calorific value	GJ/t	40,4
Fuel cost (delivered at Dire Dawa)	\$/GJ	8,1
Efficiency	%	42
Fuel cost	\$/MWh	111
Variable cost	\$/MWh	13
Total variable cost	\$/MWh	124

Table 6.1-1 - Diesel candidate characteristics

Module M3: Energy Sector Profile & Projections

VOL 3: ETHIOPIA

Parameters	unit	Combustion turbine
Type of Fuel		IDO
Capacity (ISO)	MW	70
Capacity (net)	MW net	50
Construction period	years	2 (60% & 40%)
Life span	years	20
Availability	%	85% (forced outage rate 9%)
Capital cost at site conditions	\$/kW net	830
Annuities	\$/kW /yr	115
O& M cost	\$/kW /yr	15
Total fixed capital cost	\$/kW /yr	130
Fuel calorific value	GJ/t	42,1
Fuel cost (delivered at Dire Dawa)	\$/GJ	12,6
Efficiency	%	30,6
Fuel cost	\$/MWh	95
Variable cost	\$/MWh	6
Total variable cost	\$/MWh	101

Table 6.1-2 - Combustion turbine candidate characteristics

Parameters	unit	Combined Cycle
Type of Fuel		IDO
Capacity (ISO)	MW	200
Capacity (net)	MW net	150
Construction period	years	3 (45%; 45 % & 10%)
Life span	years	20
Availability	%	83% (forced outage rate 9%)
Capital cost at site conditions	\$/kW net	1 045
Annuities	\$/kW /yr	164
O& M cost	\$/kW /yr	20
Total fixed capital cost	\$/kW /yr	184
Fuel calorific value	GJ/t	42,1
Fuel cost (delivered at Dire Dawa)	\$/GJ	12,6
Efficiency	%	44
Fuel cost	\$/MWh	67
Variable cost	\$/MWh	4
Total variable cost	\$/MWh	71

Table 6.1-3 - Combined cycle candidate characteristics

The following figure shows the “screening curve” comparison between the 3 liquid fuel-fired plant options and leads to the observations that for peaking load generation Combustion turbine options is the best one, while for base load generation the Combined cycle plant option is significantly less expensive.

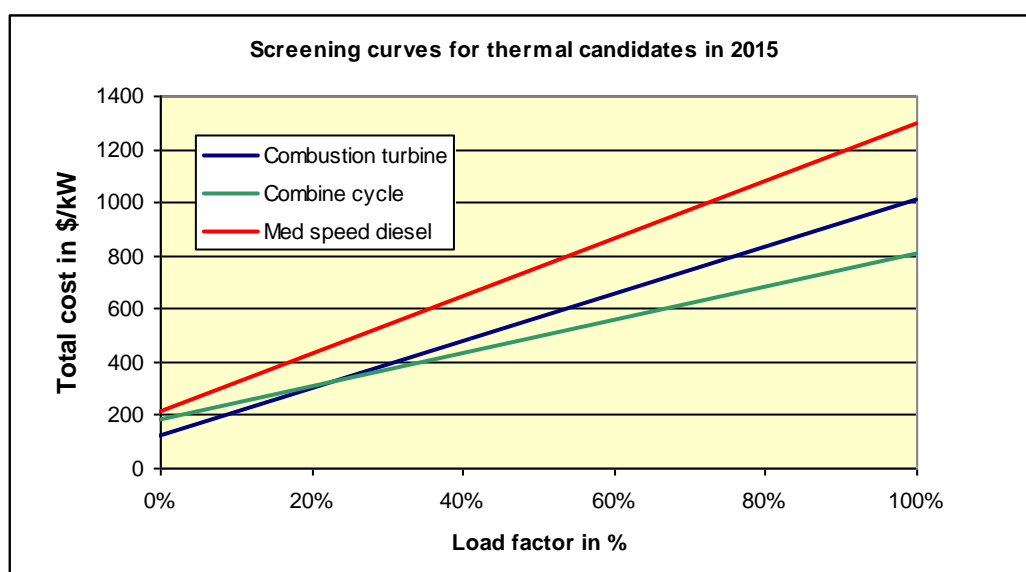

Table 6.1-4 - Screening curve for thermal candidates in 2015

6.2 HYDRO POWER PLANT PROJECTS

6.2.1 HYDRO POTENTIAL PER RIVER BASIN

Ethiopia has abundant water resources and 122 km³ of water flow through 12 large and medium sized river basins. Approximately 85% of the water resources are in the western part of the country, in the major basins of Abay, Omo-Gibe and Baro-Akobo.

The corresponding economically exploitable potential is estimated to be about 30,000 MW (160 TWh) with 20,000 MW for the three major basins.

River Basin	Catchment area	Annual runoff	Economically exploitable potential		
	(in km ²)	(in km ³)	(in TWh)	(in %)	(in MW)
Abay	199,812	52.,6	70	43	13,000
Omo-Gibe	78,200	17.9	20	16	4,000
Baro-Akobo	74,100	23.6	19.8	12	4,000
Genale-Dewa	171,050	5.8	15.7	10	3,000
Rift Valley	52,740	5.6	9.1	5.6	1,500
Tekeze	89,000	7.63	8.9	5.5	1,500
Wabe-Shebele	200,214	3.15	6.2	3.8	1,000
Awash	112,700	4.6	5.5	3.4	1,000
Mereb	5,700	0.26	0.8	0.5	100
Others	-	-	-	-	-
Total	1,136,816	122	162	100	30,000

Table 6.2-1 - Hydro potential in Ethiopia (per river basin)

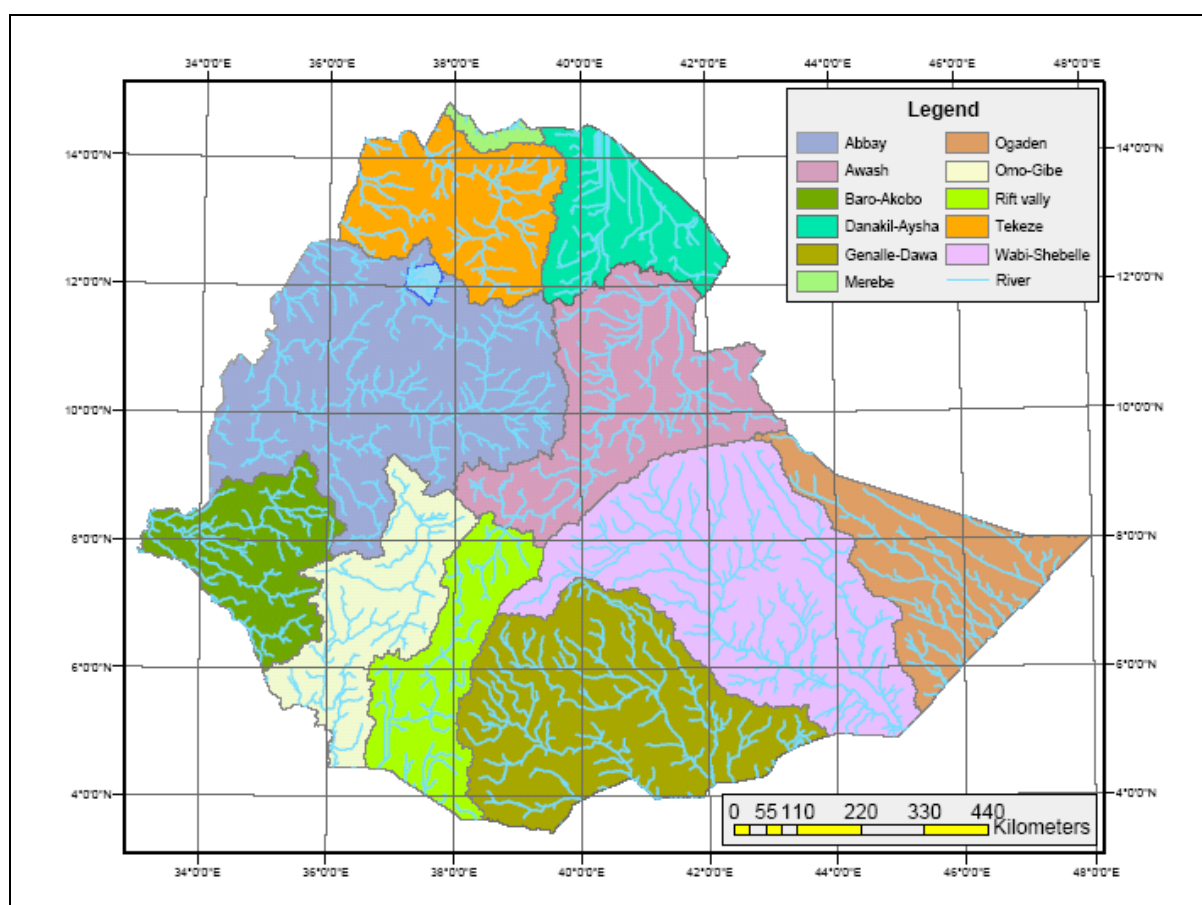

Figure 6.2-1 - Map of hydrological basins

EEPCo in its Expansion Master Plan of June 2006 foresees to operate in 2015 three new hydropower schemes: Gibe III (1,870 MW), Halele Worabesa (420 MW) and Chemoga-Yeda (280 MW).

The MoWR indicates that for the coming years several hydropower projects will be studied at feasibility level and other project studies at pre-feasibility or design level will be also committed. The total of these studies represents more than 8 000 MW of additional installed capacity, which can generate approximately 30 TWh.

The list of the main identified projects by EEPCO and MoWR is as follows:

- Aleltu East Stage 1 (186 MW),
- Aleltu West (265 MW),
- Baro I (200 MW) and Baro II (500 MW) and Gengi (200 MW),
- Geba I (286 MW) plus Geba II (157 MW),
- Genale III (258 MW) plus Genale VI (256 MW),
- Karadobi (1 600 MW),
- Border (1 200 MW) plus Mandaya (2 000 MW),
- Mabil (1 200 MW) if Mandaya (1 600 MW).

Note: The Geba I scheme and II are proposed to be developed in IPP (a MOU was signed).

The ultimate development will consist of twelve reservoirs (2,100 hm³ active storage) with a total drainage area of 2,000 km² with ten rivers.

A number of potential new projects have been studied to pre-feasibility and feasibility level. The Geba, and Aleltu East stage 1 have completed their feasibility study. The two hydroelectric power projects Baro and Genale are at the pre-feasibility stage. All of the above projects are considered as candidate projects for inclusion in the economic least-cost expansion plan for the long-term.

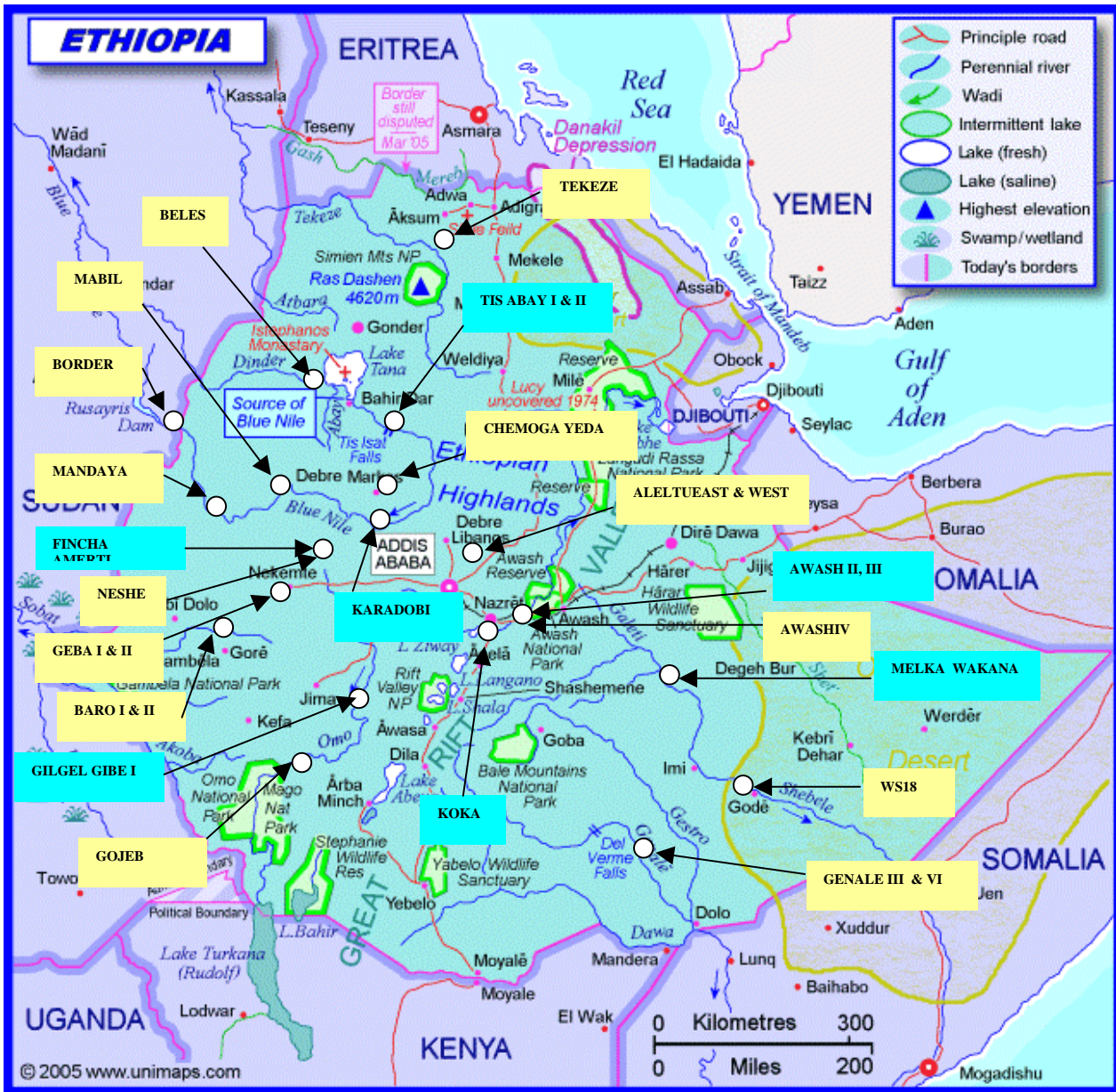

Figure 6.2-2 - Hydropower project locations

6.2.2 CONSTRUCTION AND GENERATION COST

The main source of information for the construction cost and period of the different HPP projects are found in the feasibility and pre feasibility studies of the projects.

In some studies, costs are given in USD₂₀₀₄ or USD₂₀₀₅. This costs are updated in USD₂₀₀₆ in the present Study on the basis of USD escalation between 2004, 2005 and 2006.

The generation cost per MWh (also called economic cost or levelized cost of generation) which is given in the following paragraphs for each project, could be understood as the average generation cost per MWh all over the economic life of the investment, considering all costs (investment cost and O&M cost) and the discount rate¹. The generation costs given in the following paragraph are given for a 12% discount rate. The O&M yearly costs are evaluated as 1% of the construction costs. When construction expenditure schedule is not available, the construction costs are considered equally distributed over the construction period.

6.2.3 FILLING TIME

For the purpose of information the average filling time to dead storage and to full storage is given for each project. These times are calculated on the basis of the average inflows. The filling time given for full storage includes the filling time to dead storage.

The actual filling time will depends on the repartition of inflows along the year (most inflows are concentrated on the July – October period) and on the level all annual inflow (greater or lower than the average).

HPP Project	Inflow (m ³ /s)	Annual inflow (hm ³)	Full storage (hm ³)	Active storage (hm ³)	Dead storage (hm ³)	Filling time to full storage		Filling time to dead storage	
						(year)	(month)	(year)	(month)
Halele	78	2 472	3 300	2 900	400	1.3	16.0	0.2	1.9
Worabesa	88	2 769	184	106	78	0.1	0.8	0.0	0.3
Chemoga	6	176	304	221	83	1.7	20.7	0.5	5.6
Aleltu East	5	145	167	160	7	1.2	13.8	0.0	0.6
Baro I	75	2 356	1 337	993	344	0.6	6.8	0.1	1.8
Baro II	77	2 431	73	18	55	0.0	0.4	0.0	0.3
Gengi	42	1 331	1.5	0.6	0.9	0.0	0.0	0.0	0.0
Geba I	31	971	1 470	1 392	78	1.5	18.2	0.1	1.0
Geba II	49	1 539	38	6	32	0.0	0.3	0.0	0.3
Gojeb	86	2 722	997	757	240	0.4	4.4	0.1	1.1
Genale III	96	3 034	1 940	1 140	800	0.6	7.7	0.3	3.2
Genale VI	99	3 122	50	42	8	0.0	0.2	0.0	0.0
Awash IV	39	1 243	970	100	870	0.8	9.4	0.7	8.4
Karadobi	649	20 467	40 200	17 300	22 900	2.0	23.6	1.1	13.4
Mandaya	1 000	31 536	49 200	24 586	24 614	1.6	18.7	0.8	9.4
Border	1 544	48 692	13 250	7 250	6 000	0.3	3.3	0.1	1.5

Table 6.2-2 - Filling time of HPP projects

Among the largest projects, Mandaya and Karadobi demand respectively 10 and 14 months to fill up to dead storage. This means one to two full hydrological years depending on hydrological

¹ More information on the definition and the calculation of the economic cost is given in Module 3 Vol 5 report

conditions. This filling to dead storage can be spread on several years during the duration of construction in order to minimize the downstream effect.

Once filled to dead storage, Halele, Geba I, Karadobi and Mandaya demand respectively another 14, 17, 10, and 9 months of average inflows to reach full storage.

6.2.4 PRESENTATION OF EACH PROJECT

The Gibe III project as per the recent master plan update is scheduled for operation in 2011 (first stage) and in 2012 (second stage).

6.2.4.1 Halele Werabesa (420 MW)

The Halele Worabesa hydropower project is situated about 160 km southwest of Addis Ababa.

The Halele Worabesa HPP project (HW I & II) was studied at feasibility level (Stage I in August 2000 by Lahmayer-Electrowatt- Knight Piesold and Stage II in July 2005 by Lahmayer International). The overall scheme involves two cascade projects with reservoirs at both sites.

The "Halele Worabesa Stage I" scheme will be the first development of the cascade and the Halele dam will provide the capacity to regulate the Gilgel Gibe flows.

The downstream "Halele Worabesa Stage II" scheme will be regulated by the huge Halele reservoir (inter-annual storage).

The future downstream Gilgel Gibe III HPP project will also be taking advantage of the Halele Worabesa scheme regulation, but to a lesser extent.

At Halele, an 85 m high rock fill dam (Stage I) will provide 2,900 hm³ of live storage between operating levels 1,551 m and 1,579 m. The **96 MW** powerhouse has a rated head of 89 m and a rated flow of 124 m³/s.

Halele HPP (Stage I)	Main Features
River basin	Omo Gibe
River	Gilgel Gibe
Catchment area	6,126 km ²
Mean natural inflow	78.4 m ³ /s (2,470 hm ³)
Reservoir FSL	1,579 m
Total reservoir storage	3,300 hm ³
Active reservoir storage	2,900 hm ³
Reservoir surface area at FSL	280 km ²
Rated head	89 m
Rated total flow	124 m ³ /s
Total installed capacity	96 MW
Number of units	2
Firm energy	460 GWh/year (53 MW)
Average energy	510 GWh/year
Plant factor (firm - average)	55% - 61%
Project costs (2006)	\$232 M
Including "Transmission"	
Construction period	6 years
Construction expenditures schedule	2% - 11% - 18% - 25% - 34% - 10%
Filling time to full storage	1.3 years
Filling time to dead storage	2 months
Generation cost (Economic)	\$73 /MWh

Table 6.2-3 - Halele HPP Stage I characteristics

The additional development includes a second dam and powerhouse at Worabesa (Stage II) exploiting the 310 m gross head. The Worabesa reservoir would have a live storage of 106 hm³ operating between 1 450 m and 1,460 m. The proposed installed capacity at the site is **326 MW**, with a rated head of 296 m and a rated flow of 128 m³/s.

Worabesa HPP (Stage II)	Main Features
River basin	Omo Gibe
River	Gilgel Gibe
Catchment area	6,692 km ²
Mean natural inflow	87.8 m ³ /s (2,770 hm ³)
Reservoir FSL	1,460 m
Total reservoir storage	184 hm ³
Active reservoir storage	106 hm ³
Reservoir surface area at FSL	13,4 km ²
Rated head	296 m
Rated total flow	128 m ³ /s
Total installed capacity	326 MW
Number of units	4
Firm energy	1,570 GWh/year (179 MW)
Average energy	1,735 GWh/year
Project costs (2006)	\$275 M
w/o Transmission	
Plant factor (firm - average)	55% - 61%
Construction duration	6 years
Construction expenditures schedule	2% - 11% - 18% - 25% - 34% - 10%
Filling time to full storage	2 weeks
Generation cost (Economic)	\$26 /MWh

Table 6.2-4 - Worabesa HPP Stage II characteristics

The firm production for the Halele Worabesa HPP scheme with a total installed capacity of **422 MW** will be **2,030 GWh/year** or a total cost of **\$474M (\$1,100 per kW** of installed capacity); the total average production is expected to be 2,245 GWh per year.

As per the 2003 Master Plan, the operation of Halele Worabesa hydroelectric project is not expected to have impact on the microclimate. The followings were reported to be the negative impacts of the project, which however reported to be mitigated.

- Reduction of flow downstream of the dam may affect the ecology and habitat.
- Three road crossings and a number of trails will be inundated during the development.

- Although no significant impact is expected on the quality of water in general, eutrophication is highly probable during and after the filling of the reservoirs.
- Relocation of some communities may become necessary for this project and it is expected that approximately 200 households or 635 people will need to be relocated according to a relocation plan.
- Approximately 20 577 hectares of grazing land, 3 815 hectares of forest or woodland and 1 270 hectares of cultivated land will be affected.

Estimated costs for mitigation are \$5M for stage I and \$1M for stage II.

The HW II project and I will be scheduled for operation in **2014** as per EPSEMP.

6.2.4.2 Chemoga-Yeda (280 MW)

The Chemoga-Yeda project was studied at pre-feasibility level, with a feasibility level study of the development of the first stage and second stage (May 2005 by Lahmeyer international).

The Chemoga-Yeda Stage1 HPP project comprises five medium sized dams linked by transfer tunnels.

The project CY1 (in stage 1) mainly involves the construction of a reservoir on the Yeda River and flow diversion from there to a second reservoir on the Chemoga River and a first powerhouse (162 MW), and the project CY2 (in stage 2) involves the construction of a second powerhouse (118 MW).

Chemoga reservoir would have a live storage of 221 hm³ operating between 2,417 m and 2,428 m. Yeda reservoir would have 216 hm³ live storage operating between 2,280 m and 2,290 m.

The stage 1 power station (see table below) develops 760 m of the total head between Chemoga reservoir and the tailrace. The proposed installed capacity is **162 MW**, with rated head of 761 m and rated flow of 24.6 m³/s.

The stage 2 power station (see table below) would have an installed capacity of **118 MW**, with rated head of 561 m and rated flow of 24.6 m³/s.

Chemoga-Yeda I HPP	Main Features
River basin	Abay River
Chemoga Dam	
River	Chemoga
Catchment area	364 km ²
Mean natural inflow	5.59 m ³ /s (176 hm ³)
Reservoir FSL	2,428 m
Total reservoir storage	304 hm ³
Active reservoir storage	221 hm ³
Yeda Dam	
River	Yeda
Catchment area	406 km ²
Mean natural inflow	5.41 m ³ /s (170 hm ³)
Reservoir FSL	2,290 m
Total reservoir storage	325 hm ³
Active reservoir storage	216 hm ³
Sens Dam	
River	Sens
Catchment area	35 km ²
Mean natural inflow	0.38 m ³ /s (12 hm ³)
Reservoir FSL	2,290 m
Total reservoir storage	10 hm ³
Active reservoir storage	8 hm ³
Bogena Dam	
River	Bogena
Catchment area	162 km ²
Mean natural inflow	2.22 m ³ /s (70 hm ³)
Reservoir FSL	2,493 m
Total reservoir storage	91 hm ³
Active reservoir storage	84 hm ³
Gelta Dam	
River	Gelta
Catchment area	140 km ²
Mean natural inflow	1.8 m ³ /s (57 hm ³)
Reservoir FSL	2,357 m
Total reservoir storage	73 hm ³
Active reservoir storage	60 hm ³
Rated head	761 m
Rated total flow	24.6 m ³ /s
Total installed capacity	162 MW
Number of units	2 (Pelton)
Firm energy	780 GWh/year
Project costs (2006)	\$275 M
w/o Transmission	
Plant factor (firm - average)	- %
Construction duration	6 years
Construction expenditures schedule	13% - 17% - 28% - 32% - 7% - 3%
Filling time to full storage	1.8 years
Filling time to dead storage	0.5 year
Generation cost (Economic)	\$ 61 /MWh

Table 6.2-5 - Chemoga-Yeda HPP Stage I characteristics

Note: As per the feasibility report there is no Gelta and Bogena dams and reservoirs.

Chemoga-Yeda II HPP	Main Features
River basin	Abay River
Total active reservoir storage	No reservoir
Rated head (Design)	561 m
Rated total flow (Design)	24.6 m ³ /s
Total installed capacity	118 MW
Number of units	2 (Francis)
Firm energy	568 GWh/year
Plant factor	%
Project costs (2006)	€ 127 M
w/o Transmission	
Construction period	4 years
Filling time	-
Generation cost (Economic)	\$39 /MWh

Table 6.2-6 - Chemoga-Yeda II HPP Stage 2 characteristics

The planning study included the Chemoga and Yeda reservoirs and the Stage 1 and Stage 2 power stations. The Chemoga-Yeda I and II HPP projects will be scheduled for operation in 2015 as per EPSEMP.

Note: Significant potential for irrigation had been identified in the area.

As per the 2003 Master Plan, the project may have a localised but insignificant impact on the microclimate, which cannot be mitigated. The followings were reported to be the negative impacts of the project, which however reported to be mitigated.

- Reduction of flow downstream of the dam may affect the ecology and habitat of the are to some extent can be mitigated through the release of compensation flows and the construction of flow regulating structures.
- A number of trails will be cut off during the development of the project, for which a new access road around the reservoir was proposed.
- Both the Chemoga and the Yeda rivers downstream of the proposed dams will have high negative impact in reducing the flows, as the water is transferred to a different stream.
- It was expected that approximately 1 462 households (or 6 652 people) will need to be relocated.
- Approximately 4 457 hectares of grazing land, 1 930 hectares of cultivated land and 82 hectares of forest will be affected by the project.

Estimated costs for mitigation are \$19M for stage I and \$1M for stage II.

6.2.4.3 Aleltu East (186 MW)

The Aleltu East hydropower project is located on the plateau of central Ethiopia in the Shoa administration region, approximately 100 km north of Addis Ababa. Three river basins are concerned, namely Robi Gomoro, Chacha, and Jinjer, which drain an area of 897 km² and are part of the Blue Nile basin.

Acres International completed the feasibility study for this project in 1995. In this study a **186 MW** plant was considered. The project would require construction of a dam on the Rikicha Gomoro river and an associated high head power station. Flows to the Rikicha Gomoro reservoir would be supplemented by diversion of flow from the Chacha River. A dam would be constructed on the Chacha River to store water and enable the diversion of flow to Rikicha Gomoro. The total live storage at the two reservoirs is about 520 hm³ relative to total average annual inflows of about 456 hm³, indicating a high degree of regulation.

Aleltu East HPP	Main Features
River basin	Abay river
Chacha Dam	
River	Chacha
Catchment area	591 km ²
Mean natural inflow	4,59 m ³ /s (145 hm ³)
Reservoir FSL	2,766 m
Reservoir MOL	2,761 m
Total reservoir storage	167 hm ³
Active reservoir storage	160 hm ³
Reservoir surface area at FSL	19 km ²
Rikicha Dam	
River	Rikicha Gomoro
Catchment area	898 km ²
Mean natural inflow	9.86 m ³ /s (311 hm ³)
Reservoir FSL	2,561m
Reservoir MOL	2,554 m
Total reservoir storage	367 hm ³
Active reservoir storage	360 hm ³
Reservoir surface area at FSL	21.5 km ²
Rated head (Design)	863 m
Rated total flow (Design)	24.7 m ³ /s
Total installed capacity	186 MW
Number of units	3 (Pelton)
Firm energy	780 GWh/year
Average energy	800 GWh/year
Plant factor	%
Project costs (2006)	\$438 M
w/o Transmission	
Construction period	6 years
Filling time to full storage	1.2 years
Filling time to dead storage	< 1 month
Generation cost (Economic)	\$95 /MWh

Table 6.2-7 - Aleltu East HPP characteristics

As per the 2003 Master Plan, the Phase 1 (Stage I) of the project may have a localised but insignificant impact on the microclimate, which cannot be mitigated. The followings were reported to be the negative impacts of the project that are reported to be mitigated.

- The habitat of most animal life will be permanently lost at the site where the reservoirs will be, but for fish would increase as water collect in the reservoirs.
- Eutrophication is highly probable during and after filling of the reservoirs, which may negatively effect the water quality and should be limited by clearing the dam basin of vegetation before filling.
- Transfer of water from the Chacha Reservoir to the Jinjer Reservoir will have significant negative impact on the river downstream of Chacha Reservoir.
- Aleltu East Project will have a slight local effect on communication and access, which may lead to inconvenience to residents of the area, but this should investigated in more detail.
- At Chacha, 190 households and approximately 2 000 people and at Rikicha Gomoro, 254 homes and 2 150 people will have to be resettled.
- At Chacha, 1 710 hectares of land will be lost and about 2 305 hectares at Gomoro. However, the report has not stated how much grazing land, forest, woodland/bush or cultivated will be affected in total.

Estimated costs for mitigation are \$18M.

6.2.4.4 Aleltu West (265 MW)

The Aleltu West hydropower project is situated on the three river basins of Tiliku Aleltu, Jida and Weserbi which have a total drainage area of 1,374 km², with an average inflow of 14m³/s.

The Aleltu West project was studied at pre-feasibility level in 1994 as part of an overall pre-feasibility assessment of the Aleltu area. The project is composed of reservoirs on the Jida, Weserbi and Tiliku Aleltu rivers. Flows would be diverted from Jida to Tiliku Aleltu, and flows from there plus Weserbi would feed the single power station.

Total live storage of the scheme is some 624 hm³ and would provide a high degree of regulation of the mean annual inflows of 508 hm³.

The **265 MW** powerhouse (3 Pelton turbines), located upstream of the confluence on the Agat and Zega rivers, would operate with a gross head of 1,070 m and a rated flow of 18.8 m³/s.

The firm energy production would be 983 GWh per year (plant factor of 50%) and the construction cost is estimated at \$524M.

Aleltu West I HPP	Main Features
River basin	Abay River
<u>Jida Dam</u>	
River	Jida
Catchment area	749 km ²
Mean natural inflow	6.9 m ³ /s (218 hm ³)
Reservoir FSL	2,590 m
Reservoir MOL	2,570 m
Total reservoir storage	- hm ³
Active reservoir storage	543 hm ³
<u>Tiliku aleltu Dam</u>	
River	Tiliku
Catchment area	458 km ²
Mean natural inflow	0.89 m ³ /s (28 hm ³)
Reservoir FSL	2,620 m
Reservoir MOL	2,570 m
Total reservoir storage	- hm ³
Active reservoir storage	37.7 hm ³
<u>Weserbi Dam</u>	
River	Weserbi
Catchment area	167.5 km ²
Mean natural inflow	1.56 m ³ /s (49 hm ³)
Reservoir FSL	2,620 m
Reservoir MOL	2,615 m
Total reservoir storage	- hm ³
Active reservoir storage	35.3 hm ³
Rated head	999 m
Rated total flow	30.6 m ³ /s
Total installed capacity	265 MW
Number of units	3 (Pelton)
Firm energy	983 GWh/year
Average energy	1,050 GWh/year
Project costs (2006)	\$561 M
w/o Transmission	
Plant factor (firm - average)	-%
Construction duration	- years
Generation cost (Economic)	\$93 /MWh

Table 6.2-8 - Aleltu West HPP characteristics

As per the 2003 Master Plan, the project may have a localised but insignificant impact on the microclimate, which cannot be mitigated. The followings were reported to be the negative impacts of the project that are reported to be mitigated.

- The habitat of most animal life will be permanently lost at the site where the reservoirs will be, but for fish would increase as water collect in the reservoirs.
- Eutrophication is highly probable during and after filling of the reservoirs, which may negatively effect the water quality and should be limited by clearing the dam basin of vegetation before filling.

- Regional changes in the flow regime and reduced flow in the rivers below the reservoirs should be mitigated through the construction of flow regulating structures and release of compensation flow.
- The Aleltu West project will have a slight local effect on communication and accesses, which may lead to inconvenience to residents of the area when trying to reach neighbouring communities on foot.

6.2.4.5 Baro1 & 2 and Genji (900 MW)

The Baro 1 & 2 hydropower scheme project is located 300 km of Addis Ababa in the western part of Ethiopia, south of the Addis Ababa-Gambela road between Gore and Bonga in the upper and eastern part of the Baro-Akobo basin.

The Baro scheme pre-feasibility study was completed in 1999 and identified a one-reservoir and two-plant scheme as being the most economically attractive. In May 2005, Lahmayer international completed a feasibility study for this project.

The Baro 1 reservoir would have a live storage of 993 hm³ operating between 1,485 m and 1,520 m.

The Baro 1 HPP project would have an installed capacity of **200 MW** with 185 m head and rated flow of 113 m³/s.

Baro I HPP	Main Features
River basin	Baro-Akobo river
River	Baro
Catchment area	2,231 km ²
Mean natural inflow	74.7 m ³ /s (2,355 hm ³)
Reservoir FSL	1,520 m
Reservoir MOL	1,485 m
Total reservoir storage	1,337 hm ³
Active reservoir storage	993 hm ³
Reservoir surface area at FSL	36.8 km ²
Rated head (Design)	185 m
Rated total flow (Design)	113 m ³ /s
Total installed capacity	200 MW
Number of units	2 (Francis)
Firm energy	772 GWh/year
Average energy	904 GWh/year
Plant factor	50%
Project costs (2006) w/o Transmission lines	\$ 487M
Construction period	6 years
Construction expenditure schedule	4% - 12% - 27% -29% - 25% - 4%
Filling time to full storage	7 months
Filling time to dead storage	2 months
Generation cost (Economic)	\$95 /MWh

Table 6.2-9 - Baro I HPP characteristics

The Baro 2 HPP project (run of river project) would have an installed capacity of **500 MW** with 499 m head and a rated flow of 113 m³/s.

Baro II HPP	Main Features
River basin	Baro-Akobo river
River	Baro
Catchment area	2,333 km ²
Mean natural inflow	77.1m ³ /s (2,431hm ³)
Reservoir FSL	1,320 m
Reservoir MOL	1,318 m
Total reservoir storage	73 hm ³
Active reservoir storage	18 hm ³
Reservoir surface area at FSL	9.6 km ²
Rated head (Design)	499 m
Rated total flow (Design)	113 m ³ /s
Total installed capacity	500 MW
Number of units	3 (Pelton)
Firm energy	2,085 GWh/year
Average energy	2,585 GWh/year
Plant factor	50%
Project costs (2006)	\$350 M
w/o Transmission	
Construction period	7 years
Construction expenditure schedule	3% - 11% - 15% -25% - 23% - 15% - 8%
Filling time	<1 month
Generation cost (Economic)	\$25 /MWh

Table 6.2-10 - Baro II HPP characteristics

As per the 2003 Master Plan, the Baro 1 and 2 projects may have a localised but insignificant impact on the microclimate, which cannot be mitigated. The followings were reported to be the negative impacts of the project that are reported to be mitigated.

- The habitat of most animal life will be permanently lost at the site where the reservoirs will be, but for fish would increase as water collect in the reservoirs.
- Eutrophication is highly probable during and after filling of the reservoirs, which may negatively effect the water quality and should be limited by clearing the dam basin of vegetation before filling.

Module M3: Energy Sector Profile & Projections

VOL 3: ETHIOPIA

- Regional changes in the flow regime and reduced flow in the rivers below the reservoirs should be mitigated through the construction of flow regulating structures and release of compensation flow.
- The Baro 1 and 2 projects will affect eight and ten river crossing respectively, which may lead to inconvenience to residents of the area when trying to reach neighbouring communities, unless alternative roads are provided.
- Downstream users of the water resources will experiences regional changes in the flow regime and changes in the availability of water.
- It is expected that the development of Baro 1, approximately 127 households or 493 people will have to be relocated elsewhere. For Baro 2, approximately 116 households or 412 people will need to permanently relocated
- A definite permanent impact on natural resources is expected. At Baro 1, approximately 102 hectares of grazing land, 6 400 hectares of forest, 1 002 hectares of woodland/bush, and 201 hectares of cultivated land will be affected. Baro 2 will impact on about 102 hectares of grazing land 5 104 hectares of forest, 342 hectares of woodland, and 109 hectares of cultivated land.

Estimated costs for mitigation are \$5,4M.

The Genji HPP project (run of river conception) would have an installed capacity **214 MW** with 380 m head and a rated flow of 63 m³/s.

Genji HPP	Main Features
River basin	Baro-Akobo river
River	Genji
Catchment area	1,380 km ²
Mean natural inflow	42.2 m ³ /s (1,330 hm ³)
Reservoir FSL	1,200 m
Reservoir MOL	1,197 m
Total reservoir storage	1.5 hm ³
Active reservoir storage	0.6 hm ³
Reservoir surface area at FSL	0.224 km ²
Rated head (Design)	380 m
Rated total flow (Design)	62 m ³ /s
Total installed capacity	200 MW
Number of units	2 (Pelton)
Firm energy	GWh/year
Average energy	920 GWh/year
Plant factor	%
Project costs (2006)	\$138,6 M
w/o Transmission	
Construction period	4 years
Filling time	< 1 month
Generation cost (Economic)	\$27 /MWh

Table 6.2-11 - Genji HPP characteristics

The average production for the Baro HPP scheme (Baro I & II and Genji) with a total installed capacity of **714 MW** will be **4.3 TWh/year** for a total cost of **\$1,315M** (\$1,800 per kW of installed capacity) including an amount of \$339M for transmission lines.

6.2.4.6 Geba I & II (370 MW)

The Geba Hydropower scheme project is located in the western part of Ethiopia, in the upper and eastern part of the Baro-Akobo basin. The Geba river is the most eastern tributary of the Baro river.

The Geba multi-purpose project feasibility study was completed in February 2005 by Norplan–Norconsult Association, and identified a one-reservoir, two-plant scheme as being the most economic alternative for the Geba River. The Geba reservoir would have live storage of some 1,392 hm³ operating between 2,180 m and 2,160 m.

The installed capacities of the two plants would be **214,5 MW** for Geba I (GB1) and **157 MW** for Geba II (GB2). Rated heads and flows are 480 m and 50 m³/s for Geba I, and 267 m and 65 m³/s for Geba II. The reservoir inflows for the Geba project were estimated from the Sor river at Metu. There are no significant inflows between the reservoir and the two plants.

Geba I HPP	Main Features
River basin	Baro-Akobo river
River	Geba
Catchment area	993 km ²
Mean natural inflow	30.8 m ³ /s (977 hm ³)
Reservoir FSL	2,180 m
Reservoir MOL	2,160 m
Total reservoir storage	1,470 hm ³
Active reservoir storage	1,392 hm ³
Reservoir surface area at FSL	115.7 km ²
Rated head (gross)	480 m
Rated total flow (max)	50 m ³ /s
Total installed capacity	215 MW
Dependable capacity	194 MW
Number of units	3 (Francis)
Firm energy	- GWh/year
Average energy	935 GWh/year
Plant factor	%
Project costs (2006)	\$295 M
including "Transmission lines"	\$37.2 M
Construction period	6 years
Construction expenditure schedule	10% - 16% - 19% - 25% - 23% - 8%
Filling time to full storage	1.5 year
Filling time to dead storage	1 month
Generation cost (Economic)	\$55 /MWh

Table 6.2-12 - Geba I HPP characteristics

Geba II HPP	Main Features
River basin	Baro-Akobo river
River	Geba
Catchment area	1,570 km ²
Mean natural inflow	48.8 m ³ /s (1,546 hm ³)
Reservoir FSL	1,700 m
Reservoir MOL	1,698 m
Total reservoir storage	38.3 hm ³
Active reservoir storage	6 hm ³
Reservoir surface area at FSL	1.8 km ²
Rated head (gross)	267 m
Rated total flow (max)	65 m ³ /s
Total installed capacity	157 MW
Dependable capacity	153 MW
Number of units	2 (Francis)
Firm energy	GWh/year
Average energy	853 GWh/year
Plant factor	%
Project costs (2006)	\$124 M
Including "Transmission lines"	\$2,6 M
Construction period	5 years
Construction expenditure schedule	7% - 18% - 34% - 29% - 11%
Filling time	< 1 month
Generation cost (Economic)	\$23 /MWh

Table 6.2-13 - Geba II HPP characteristics

The construction of the Geba dam increases the flow of the Baro river at Gambela by 20 m³/s, which can be used for irrigation of the Gambela area.

The potential in the downstream Geba river is in the range of 1,100 MW with the four hydropower plant projects: Geba III (80 MW), Geba IV (150 MW), Geba V (150 MW) and Geba VI (750 MW).

As per the 2003 Master Plan, the Geba 1 and 2 projects may have a localised but insignificant impact on the microclimate, which cannot be mitigated. The followings were reported to be the negative impacts of the project that are reported to be mitigated.

- The habitat of most animal life will be permanently lost at the site where the reservoirs will be built, but the habitat for fish would increase as water collect in the reservoirs.

- Eutrophication is highly probable during and after filling of the reservoirs, which may negatively effect the water quality and should be limited by clearing the dam basin of vegetation before filling.
- Regional changes in the flow regime and reduced flow in the rivers below the reservoirs should be mitigated through the construction of flow regulating structures and release of compensation flow.
- The Geba 1 and 2 projects will affect three and five river crossing respectively, which may lead to inconvenience to residents of the area when trying to reach neighbouring communities, unless alternative roads are provided.
- Downstream users of the water resources will experiences regional changes in the flow regime and changes in the availability of water.
- It is expected that the development of Geba 1, approximately 97 households or 471 people will have to be relocated elsewhere. For Geba 2, approximately 34 households or 163 people will need to permanently relocated
- Malaria and bilharzias may occur at the sites of both Geba 1 and Geba 2, which may impact negatively on the health of residents of the area, for which effective control of disease-causing vectors would be an important countermeasure.
- A definite permanent impact on natural resources is expected. At Geba 1, approximately 4 354 hectares of grazing land, 1 720 hectares of forest, 190 hectares of woodland/bush, and 100 hectares of cultivated land will be affected. Geba 2 will impact on about 4 320 hectares of grazing land 1 920 hectares of forest, 130 hectares of woodland, and 89 hectares of cultivated land.

Estimated costs for mitigation are \$3,1M for Geba I and \$0,5M for Geba II.

6.2.4.7 Gojeb (153 MW)

The Gojeb project was studied to feasibility level in 1997 (Howard Humphreys & Partners) with its design also completed by then. The plant was to be committed for the short term if the contract with an IPP proved to be sound. The plant is designed with an installed capacity of 153 MW, although the initial installation is proposed to be 102 MW. The dam will impound some 757 hm³ of live storage between LSL and FSL of 1,067.5 m and 1,110 m. With mean annual inflows of about 2,720 hm³, it can be seen that the degree of regulation is quite small.

Gojeb HPP	Main Features
River basin	Omo Gibe
River	Gojeb
Catchment area	5,390 km ²
Mean natural inflow	86.3 m ³ /s (2,720 hm ³)
Reservoir FSL	1,110 m
Reservoir MOL	1067,5 m
Total reservoir storage	997 hm ³
Active reservoir storage	757 hm ³
Reservoir surface area at FSL	26.9 km ²
Rated head (max)	111 m
Rated total flow	160 m ³ /s
Total installed capacity	153 MW
Dependable capacity	69 MW
Number of units	3
Firm energy	364 GWh/year (41,6 MW)
Average energy	520 GWh/year
Plant factor	50%
Project costs (2006)	\$288 M
including Transmission	(\$10,1 M)
Construction period	5 years
Construction expenditure schedule	9% - 16% - 30% - 30% - 15%
Filling time to full storage	< 5 months
Filling time to dead storage	< 2 months
Generation cost (Economic)	\$91 /MWh

Table 6.2-14 - Gojeb HPP characteristics

The firm production for the Gojeb HPP scheme, with a total installed capacity of **153 MW**, will be **364 GWh/year** or a total cost of **\$268M (\$1,750 per kW** of installed capacity); the total average production is expected to be **520 GWh** per year.

No environmental report is available for the time being.

6.2.4.8 Genale III and VI (511 MW)

The Genale 3 & 6 hydropower projects are situated 500 km south of Addis Ababa, in the upper part of the Genale River basin in the Oromya region.

The Genale pre-feasibility study was completed in 1999 and identified a two-plant, two-reservoir scheme as being the most promising overall project for the Genale River.

The two plants are Genale III HPP and Genale VI HPP, with proposed installed capacities of **254 MW** and **257 MW** respectively. The Genale III HPP project was studied to feasibility level in 2005 and the Genale VI project was studied to pre-feasibility level in 2006 by Lahmayer International.

The Genale III reservoir would have a live storage of 1,700 hm³ operating between 1,100 m and 1,060 m.

The rated flows and heads are 175 m³/s and 166 m for Genale VI, and 100 m³/s and 186 m for Genale III.

Module M3: Energy Sector Profile & Projections

VOL 3: ETHIOPIA

Genale III HPP	Main Features
River basin	Genale-Dawa river
River	Genale
Catchment area	10,445 km ²
Mean natural inflow	96.2 m ³ /s (2 920 hm ³)
Reservoir FSL	1,100 m
Reservoir MOL	1,060 m
Total reservoir storage	1 940 hm ³
Active reservoir storage	1 140 hm ³
Reservoir surface area at FSL	72 km ²
Rated head (gross)	186 m
Rated total flow (max)	116 m ³ /s
Total installed capacity	254 MW
Number of units	-
Firm energy	about 1200 GWh/year
Average energy	about 1200 GWh/year
Plant factor	%
Project costs (2006)	\$303.5 M
Including "Transmission lines"	\$ 31.2M
Construction period	5 years
Filling time to full storage	8 months
Filling time to dead storage	3 months
Generation cost (Economic)	\$40 /MWh

Table 6.2-15 - Genale III HPP characteristics

Module M3: Energy Sector Profile & Projections

VOL 3: ETHIOPIA

The characteristics from the Pre-Feasibility Study of GD3 (2-2 and 2-2, 6-40, 7-24) were:

Genale VI HPP	Main Features
River basin	Genale-Dawa river
River	Genale
Catchment area	13,356 km ²
Mean natural inflow	99 m ³ /s (3,125 hm ³)
Reservoir FSL	570 m
Reservoir MOL	550 m
Total reservoir storage	50 hm ³
Active reservoir storage	42 hm ³
Reservoir surface area at FSL	4 km ²
Rated head (gross)	166 m
Rated total flow (max)	175 m ³ /s
Total installed capacity	256 MW
Number of units	3 (Francis)
Firm energy	1, 010 GWh/year
Average energy	1,224 GWh/year
Plant factor	55%
Project costs (2006)	\$ 383 M
including "Transmission lines"	\$19,5 M
Construction period	4 years
Filling time	6 days
Generation cost (Economic)	\$60 /MWh

Table 6.2-16 - Genale VI HPP characteristics

One option for both Genale III & VI HPP is export of their production to Kenya by a HVDC connection between the Genale III power station and Nairobi.

No environmental report is available for the time being.

6.2.4.9 Awash IV (38 MW)

The Awash IV hydropower project is along the middle course of the Awash river about 20 km south-east of Nazareth.

Electroconsult and Tropics CE completed the Awash IV project feasibility study in June 2006.

Module M3: Energy Sector Profile & Projections

VOL 3: ETHIOPIA

Three HPP have been installed upstream of the project: Koka (43 MW), Awash II & III HPP (2 x 32 MW). Koka HPP with a live storage which amounted to 1,78 km³ in 1960, has now decreased to about 1 km³ due to continuous sedimentation processes.

Several irrigation systems exist or are planned between the Koka HPP and the project as sugar plantations.

Awash IV HPP	Main Features
River basin	Awash
River	Awash
Catchment area	12,256 km ²
Mean natural inflow	39.4 m ³ /s (1,242 hm ³)
Reservoir FSL	1,407m
Total reservoir storage	970 hm ³
Active reservoir storage	100 hm ³
Reservoir surface area at FSL	17.2 km ²
Rated head (max)	63 m
Rated total flow	66 m ³ /s
Total installed capacity	38 MW
Number of units	2 (Francis)
Firm energy (50 years)	144 GWh/year (170/120)
Average energy	160 GWh/year
Plant factor	40%
Project costs (2006)	\$49 M
Including Transmission lines	(2.5 M\$)
Construction period	2 years
Construction expenditure schedule	40% - 60%
Filling time to full storage	< 10 months
Filling time to dead storage	< 9 months
Generation cost (Economic)	\$42 /MWh

Table 6.2-17 - Awash IV HPP characteristics

The average total energy generated by the Awash IV HPP will progressively decrease due to the effects of the Koka reservoir sedimentation (if no remedial measures are not taken). The average energy is estimated at 144 GWh (from 160 to 132 GWh after 50 years of operation).

The active storage will decrease from 800 hm³ to 400 hm³ during the 50-year period due to Koka reservoir sedimentation (a sedimentation rate of 10/15 hm³ per year).

The water demand for irrigated land (sugar plantation area) and domestic use (Nazareth) will rise from 2 to 5 m³/s.

Estimated costs for mitigation are \$1M.

6.2.4.10 Karadobi (1600 MW)

The Karadobi hydropower project will be located on the Abay River to the north west of Addis Ababa, approximately 55 km south of Debre Markos and downstream of the confluence of Abay and Guder rivers.

Norplan and Norconsult completed the Karadobi project pre-feasibility study in May 2006.

The plant is designed with an installed capacity of **1,600 MW** and a feasibility study is ongoing (the final report is expected in 2007).

The 1,600 MW Karadobi HPP project will produce **8,6 TWh** annual average energy with the Beles under construction (transfer of water to other basin). An additional downstream production of 2.6 TWh is also expected.

The average volume of sediment is estimated at 75 hm³ per year.

Karadobi HPP	Main Features
River basin	Abay river
River	Abay
Catchment area	66,910 km ²
Mean natural inflow	649 m ³ /s (20.5 km ³)
Reservoir FSL	1,146 m
Reservoir MOL	1,100 m
Total reservoir storage	40,200 hm ³
Active reservoir storage	17,300 hm ³
Reservoir surface area at FSL	460 km ²
Rated head (max)	214 m
Rated total flow	800 m ³ /s
Total installed capacity	1,600 MW
Number of units	8 (Francis)
Firm energy (with Beles)	8,3 TWh/year
Average energy (With Beles)	8,6 TWh/year
Additional firm production	2.6 TWh/year
Plant factor	66%
Project costs (2006)	\$2231 M
Including Transmission lines	(\$315 M)
Construction period	7,5 years
Construction expenditure schedule	5% - 9% - 13% - 20% - 18% - 15% - 11% - 10%
Filling time to full storage	2 years
Filling time to dead storage	< 14 months
Generation cost (Economic)	\$50 /MWh

Table 6.2-18 - Karadobi HPP characteristics

Note: The filling (2 years) of the reservoir will be a very crucial operation and also problematic for regulation of the Nile river downstream.

The per the 2006 draft Final Report for the Pre-Feasibility study of Karadobi Multi Purpose Project, Volume 5 (INITIAL ENVIRONMENTAL ASSESSMENT DRAFT FINAL) the following were concluded:

- There will be a potentially very serious loss of resources and income generating opportunities for some of the estimated 4,666 households in the DIZ. An estimated 3,511 ha of cultivated land and 28,629 ha of grazing land will be lost.
- No negative impacts in the SIZ in Ethiopia are anticipated.
- Likely significant positive benefits will accrue for irrigation agriculture in the SIZ in Sudan.
- There may be possible benefits for irrigation in the TIZ in Egypt.
- There will be a likely negative impact on a proportion of the 18,000 ha used for recession agriculture in the SIZ in Sudan.
- The feasibility of compensation floods will need to be examined.
- On the terrestrial ecology side, a total of 45,500 ha of land will be inundated in the DIZ including between 820-900 ha of vegetated wetland, 216 ha of riverine woodland, 6,066 ha of undisturbed woodland and 23,116 ha of partially disturbed dryland woodland.
- On the aquatic ecology side, the Karadobi dam will constitute a complete barrier to fish migration both upstream and downstream. However, from what is known of the fish fauna in the Abay at this time this impact is not considered serious.
- It is unlikely that there will be any threat to aquatic biodiversity with the implementation of the scheme, though previously unrecorded fish species may exist in springs and smaller side tributaries to the reservoir.

Estimated costs for mitigation are \$60M.

6.2.4.11 Mabil (1 200 MW)

The Mabil site will be located on Abay River 150 km downstream of the Karadobi site and downstream of the Birr River.

Very few data is available. Mabil HPP project is incompatible with Mandaya. The pre-feasibility Study carried out in Module 5 of the present Study demonstrated that Mandaya project is more interesting than Mabil one.

The details of the scheme as proposed by USBR (1964) are as follows:

Mabil HPP	Main Features
River basin	Abay river
River	Abay
Catchment area	- km ²
Mean natural inflow	- m ³ /s (- hm ³)
Reservoir FS	906 m
Total reservoir storage	- hm ³
Active reservoir storage	- hm ³
Reservoir surface area at FSL	- km ²
Rated head (max)	113.6m
Rated total flow	- m ³ /s
Total installed capacity	1,200 MW
Number of units	12 (Francis)
Average energy	5,3 TWh/year
Plant factor	-%
Project costs (2004)	\$- M
Including Transmission lines	(\$- M)
Construction period	- years
Filling time	1,5 years
Generation cost (Economic)	\$- /MWh

Table 6.2-19 - Mabil HPP characteristics

No environmental report is available for the time being.

6.2.4.12 Mandaya (2 000 MW)

The Mandaya site will be located on Abay River 180 km downstream of the Mabil site and downstream of the Didessa River.

Mandaya is currently studied at the pre-feasibility level within the present Study (see Module 5). The best option currently identified in the pre-feasibility study (Module M5) is one dam at Mandaya site with a 800 m-FSL.

Mandaya HPP	Main Features
River basin	Abay river
River	Abay
Catchment area	- km ²
Mean natural inflow	1 000 m ³ /s (31 500 hm ³ /year)
Reservoir FSL	800 m
Total reservoir storage	49 200 hm ³
Active reservoir storage	22 600 hm ³
Reservoir surface area at FSL	736 km ²
Rated head (max)	m
Rated total flow	1 337 m ³ /s
Total installed capacity	2 000 MW
Number of units	8 x 250 MW
Average energy	12.1 TWh/year
Firm energy	11.2 TWh/year
Plant factor	-%
Project costs (2006)	2 477 MUSD
Including Environ. Mitigation cost	23 MUSD
Construction period	6 years (to be confirmed in Module 5)
Filling time to full storage	1.6 years
Filling time to dead storage	< 10 months
Generation cost (Economic)	\$ 36 /MWh

Table 6.2-20 - Mandaya HPP characteristics

River flows at Mandaya (1,000 m³/s or 31,000 hm³) are approximately 60% greater than Karadobi (649 m³/s). Average evaporation at the reservoir amounts to 18 m³/s. The large storage for sediment ensures a long life of the reservoir.

A first estimation of the Environmental Mitigation cost amounts to 23 MUSD₂₀₀₆ (see Pre-feasibility Study in Module 5).

6.2.4.13 Border (1200 MW)

The Border site will be located on the Abay River, in the most downstream of the hydropower sites under consideration on the Blue Nile River, at the Sudan border and downstream of the Beles River in the Benishangul Gumuz region.

Module M3: Energy Sector Profile & Projections

VOL 3: ETHIOPIA

Part of the flow diverted from the Tana Lake by the Beles scheme (85 m³/s) would be recovered at the Border site.

The best option currently identified in the pre-feasibility study (Module M5) carried out within the present ENTRO study is a 580 m-FSL. The main characteristics of the scheme are as follows:

Border HPP	Main Features
River basin	Abay river
River	Abay
Catchment area	- km ²
Mean natural inflow	1 544 m ³ /s (48 700 hm ³ /year)
Reservoir FSL	580 m
Total reservoir storage	13 250 hm ³
Active reservoir storage	10 400 hm ³
Reservoir surface area at FSL	574 km ²
Rated head (max)	m
Rated total flow	1 700 m ³ /s
Total installed capacity	1 200 MW
Number of units	6 x 200 MW
Average energy	6 000 TWh/year (8 100 TWh with Mandaya)
Firm energy	4000 TWh/yea (7 400 TWh with Mandaya)r
Plant factor	-%
Project costs (2006)	1 442 MUSD
Including Environ. Mitigation cost	91 MUSD
Construction period	6 years (to be confirmed in Module 5)
Filling time to full storage	< 4 months
Filling time to dead storage	2 months
Generation cost (Economic)	\$42 /MWh

Table 6.2-21 - Border HPP characteristics

River natural flows at Border (1,544 m³/s or 48,660 hm³) are approximately 140% greater than Karadobi (649 m³/s).

Note: The average annual flow at the Border site would be less variable after the construction of the three main reservoirs and would be reduced by about 10% with a full irrigation development

and evaporation, and 10 km³ of sediments would be trapped within 50 years in the three reservoirs.

A first estimation of the Environmental Mitigation cost amounts to 91 MUSD₂₀₀₆ (see Pre-feasibility Study in Module 5).

6.2.5 EVAPORATION

Data relative to evaporation in the main reservoirs are presented in appendix M3 Vol 3 – 1.

6.2.6 HPP SEQUENCING

On the basis of the previous description, it is possible to summarize the compatibility / incompatibility between HPP projects as well as sequencing inside different stages of a HPP project:

- Mabil is incompatible with Mandaya;
- Baro I (reservoir & hydro plant) precedes Baro II;
- Geba I (reservoir & hydro plant) precedes Geba II.

6.2.7 SUMMARY TABLE OF HYDRO CANDIDATES

The hereafter table summarizes the main characteristics of the 16 hydro power candidates.

The following abbreviations are used to describe the level of study:

- R: Reconnaissance
- PF: Pre-feasibility study
- F: Feasibility study
- D: Design study

Comments:

The quality and precision of the data is variable from one project to another.

- 2 projects have been studied to the design stage.
- 8 projects have been studied to the feasibility stage.
- 7 projects have been studied to the pre-feasibility stage. One of them, Karadobi is currently studied to the feasibility stage. Mandaya and Border are currently studied to the pre-feasibility stage.
- Awash IV project is only mentioned for information. It has only local significance and will not be considered in the economic Study (Module 6).

Module M3: Energy Sector Profile & Projections

VOL 3: ETHIOPIA

Project name	Level of study (&date of study)	Installed capacity MW	Average energy GWh/year	Firm energy GWh/year	Project cost USD₀₆ M	Economic cost USD₀₆/MWh (discount rate 10%)	Economic cost USD₀₆/MWh (discount rate 12%)	Comments
Halele Worabesa	F (2000 & 2005)	420	510 + 1735	460 & 1570	232 & 275	60 & 21	73 & 26	financed project ?
Chemoga-Yeda	F (2005)	162 + 118		780 + 568	285 & 127	49 & 31	61 & 39	
Aleltu East	F (1995 ?)	186	800	780	438	77	95	
Aleltu West	PF (1994 ?)	265	1 050	983	560	76	93	
Baro I & II & Gengi	F (2005)	200 + 500 + 200	904 + 385 + 920	770 & 2 085	487, 350 & 139	78 & 20 & 22	95 & 25 & 27	
Geba I & II	F (2005)	215 + 157	935 + 853		295 & 124	45 & 19	55 & 23	multi purpose
Genale III & VI	F & PF (2006)	254 + 256	1 200 + 1 000	1 200 & 1 010	? & 383	34 & 50	40 & 60	possible HVDC link to Kenya
Karadobi	PF (2006) F (2007?)	1 600	8 600 (with BELES)	8 300 (with Beles)	2 231	40	50	+ 2.6 TWh downstream
Mabil	PF (?)	1 200	5 300					Incompatible with Mandaya
Mandaya	PF (2007)	2 000	12 100	11 200	2 477	29	36	Pre-feasibility studies carried out in Module 5
Border	PF (2007)	1 200	6 000 (wo Mandaya)	4 000 (wo Mandaya)	1 442	34	42	Pre-feasibility studies carried out in Module 5
Gojeb	D (1997)	153	520	364	287	74	91	IPP ?
Awash IV	F (2006)	38	160	144	49	36	42	irrigation

Table 6.2-22 - Summary list of hydro power

6.2.8 HYDROLOGIC RELIABILITY FOR THE SYSTEM

The design of the hydropower plants in the existing Ethiopian Interconnected System (ICS) has been based on the maximization of firm energy, rather than average energy. The reason for this is that the existing thermal capacity is small, and thus non-firm energy has very little, if any, value. Accordingly, reservoirs have been sized to capture the rainy season run-off, which occurs over a brief period in the late summer, with the stored water being gradually released over the ensuing dry season. This also affects the style of operation of the plants to a certain extent as more spill is induced in the effort to maintain a high reservoir level to protect against a possible drought.

The Ethiopian ICS is essentially a pure hydro system, and the provision of sufficient firm energy is crucial to its successful operation. The definition of sufficient firm energy is the subject of much debate.

For the system as a whole, a definition of firm energy is required. A brief analysis was undertaken based on the existing and committed system. Considering the foregoing, it was decided to define the firm energy of the system as the reliable level of generation that can be sustained throughout a critical drought with the available stream flow regulated by the available reservoir storage. Note that this does not mean 100% reliability of the firm energy.

In the previous section the Consultant uses the same definition for average and firm energy as in the EPSEMPU:

- the average energy of an hydro plant is the average energy generated by the plant over the 37-year hydrological reference period used in the EPSEMPU,
- the firm energy of an hydro plant is the energy generated by the plant with a probability of 36 / 36, i.e. 97.3%.

6.2.9 OTHER RELEVANT DATA

Other data required to develop the system network model are abstractions for town/village water supply or irrigation, operating constraints due to any items such as flood control, and any compensation flows that are required (whether through the turbines or by-passing them).

For Koka reservoir, data on downstream abstractions before Awash II and minimum flows downstream of Awash III were obtained from the operation group. Flood control operations at Koka were discussed, and it was agreed that the strategies to be adopted would have no impact on long-term reservoir operating policies. For all candidate projects, information on compensation flows was collected and, where available, included in the network model.

6.2.10 SMALL HYDRO GENERATION

Numerous promising sites have been identified in the past and for some, studies have been carried out to feasibility levels by several consultants such as UNDP, Lahmeyer, etc., though so far few have been developed. These stations range from an approximately 300 kW run-of-river plant to a 6,500-10,000 kW storage plant.

Module M3: Energy Sector Profile & Projections

VOL 3: ETHIOPIA

The available generating capacity in these locations typically exceeds the energy and power demand of any single community in the vicinity. As a result the plans for these developments include line extensions to several nearby towns and villages.

For some of these projects grid connection is envisaged in the near future, while some may continue as SCS until grid connection becomes necessary. A few of the existing and identified projects are listed in the table below.

Keto, Aweto, Negesso, Bonoro and Hoha have been studied to feasibility level by Chinese consultants, while Hoha has previously been studied by UNDP consultants.

Plants and Projects	Rated Capacity	Number	Annual Energy
	MW	of units	GWh/yr
Sor I (*)	5	2	49
Dembi (*)	0.8	2	-
Yadot (*)	0.75	2	-
Sor II	10	2	-
Neri I	4	2	35
Neri II	2.5	-	-
Achani	1.5	3	6.3
Aleltu	0.31	1	-
Hoha	1.1	2	6.9
Weyib	1.0	2	1,1

Table 6.2-23 - Small hydro plants projects

(*): Existing plants

6.2.11 SCHEMATIC CONFIGURATION OF RIVER SYSTEM

Module M3: Energy Sector Profile & Projections

VOL 3: ETHIOPIA

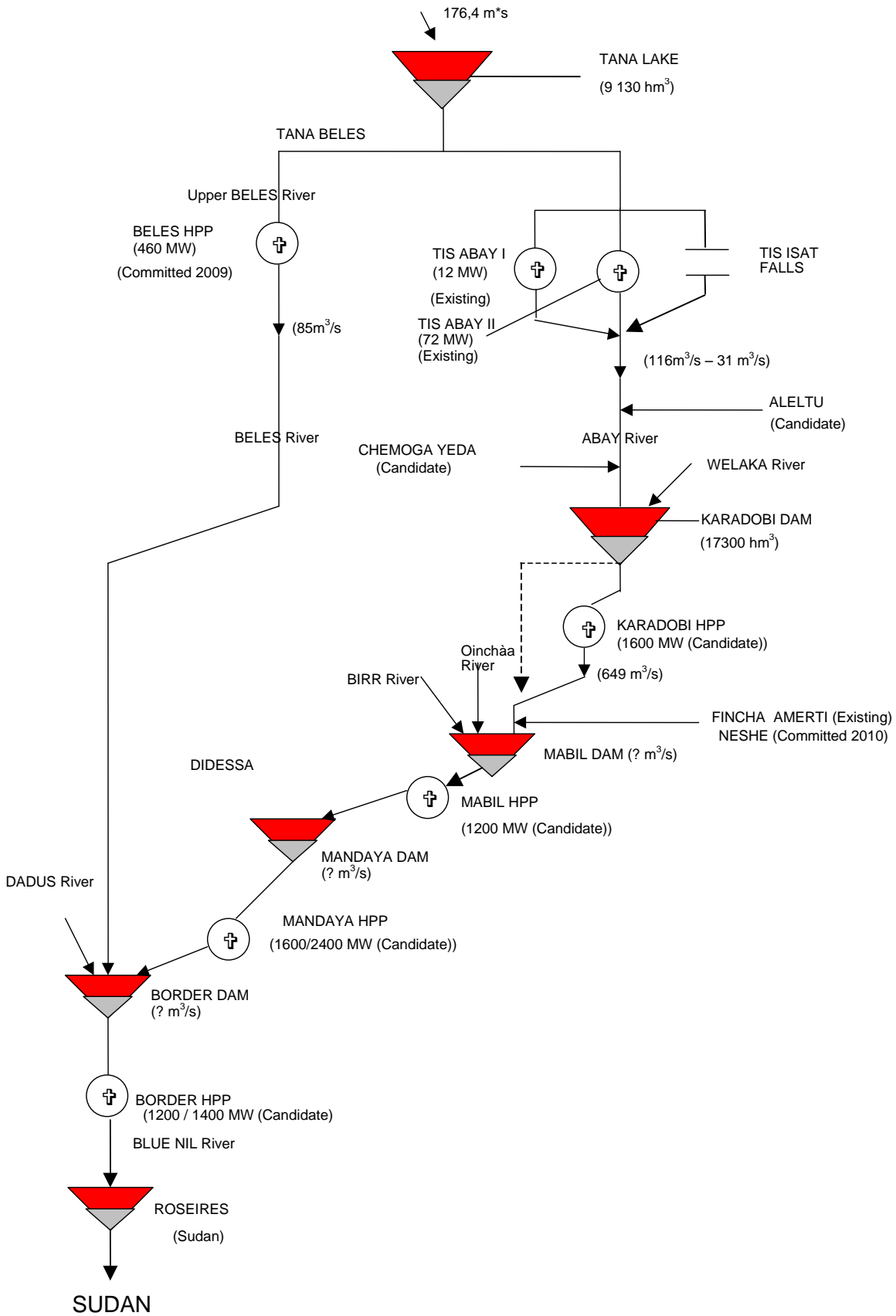

Figure 6.2-3 - Schematic configuration of Abay river system

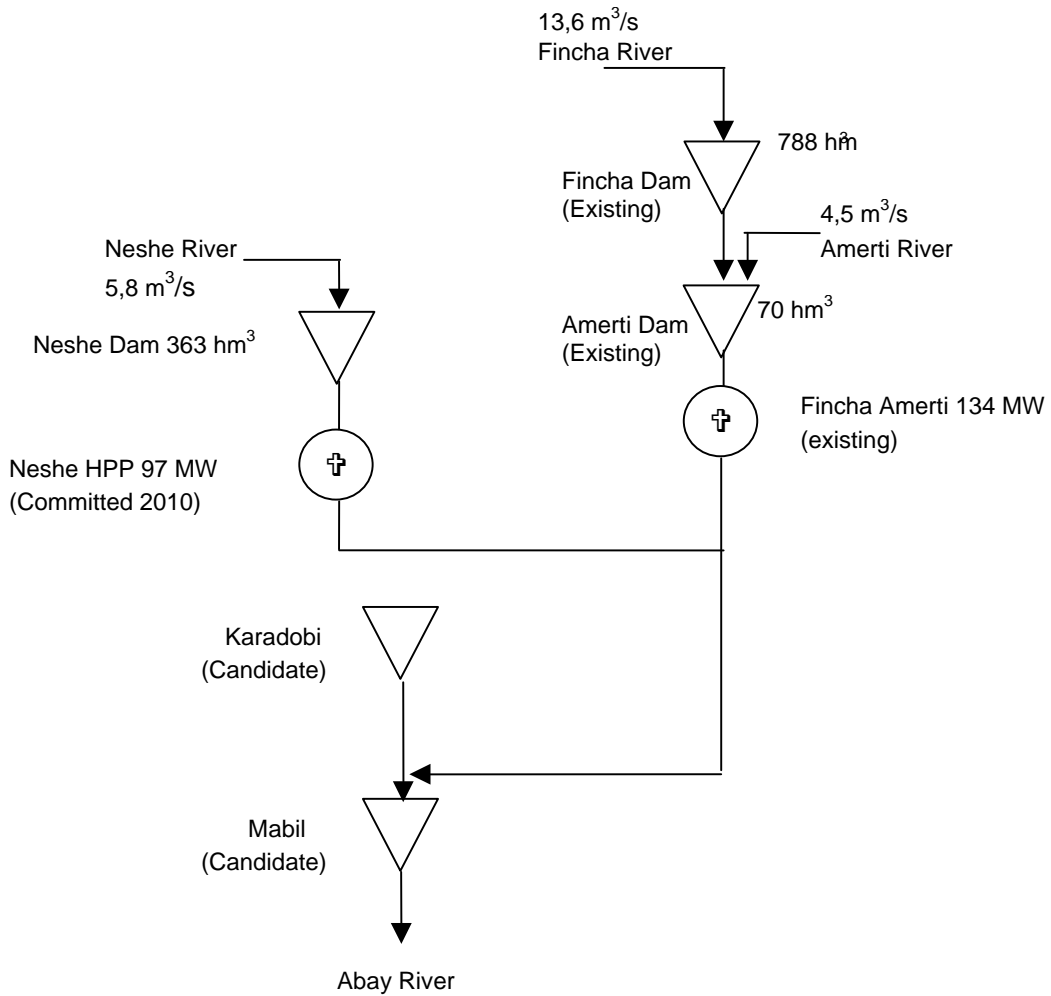

Figure 6.2-4 - Zoom Fincha Amerti Neshe

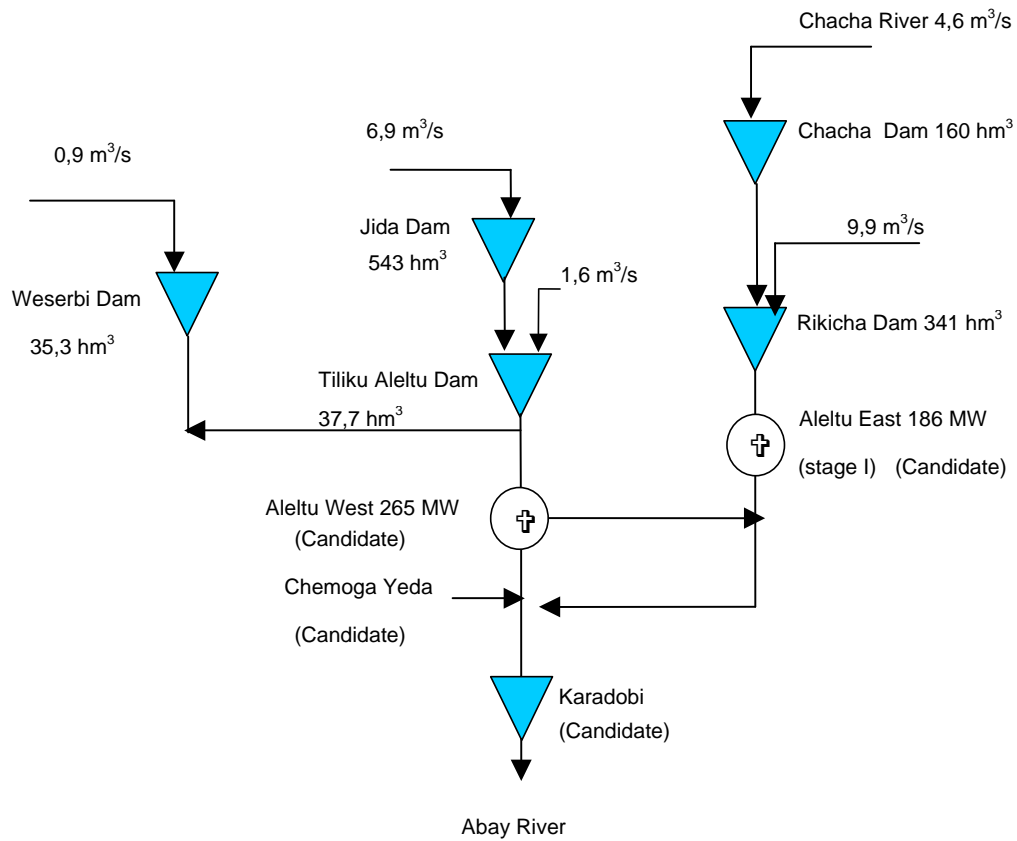
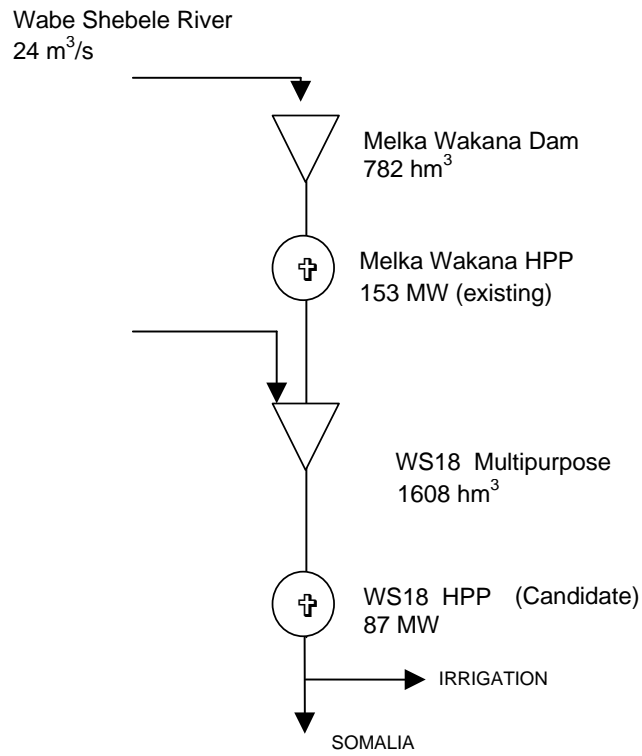

Figure 6.2-5 - Zoom Aleltu

Module M3: Energy Sector Profile & Projections

VOL 3: ETHIOPIA



WABE SHEBELE

Figure 6.2-6 - Schematic configuration of Wabe Shebele river system

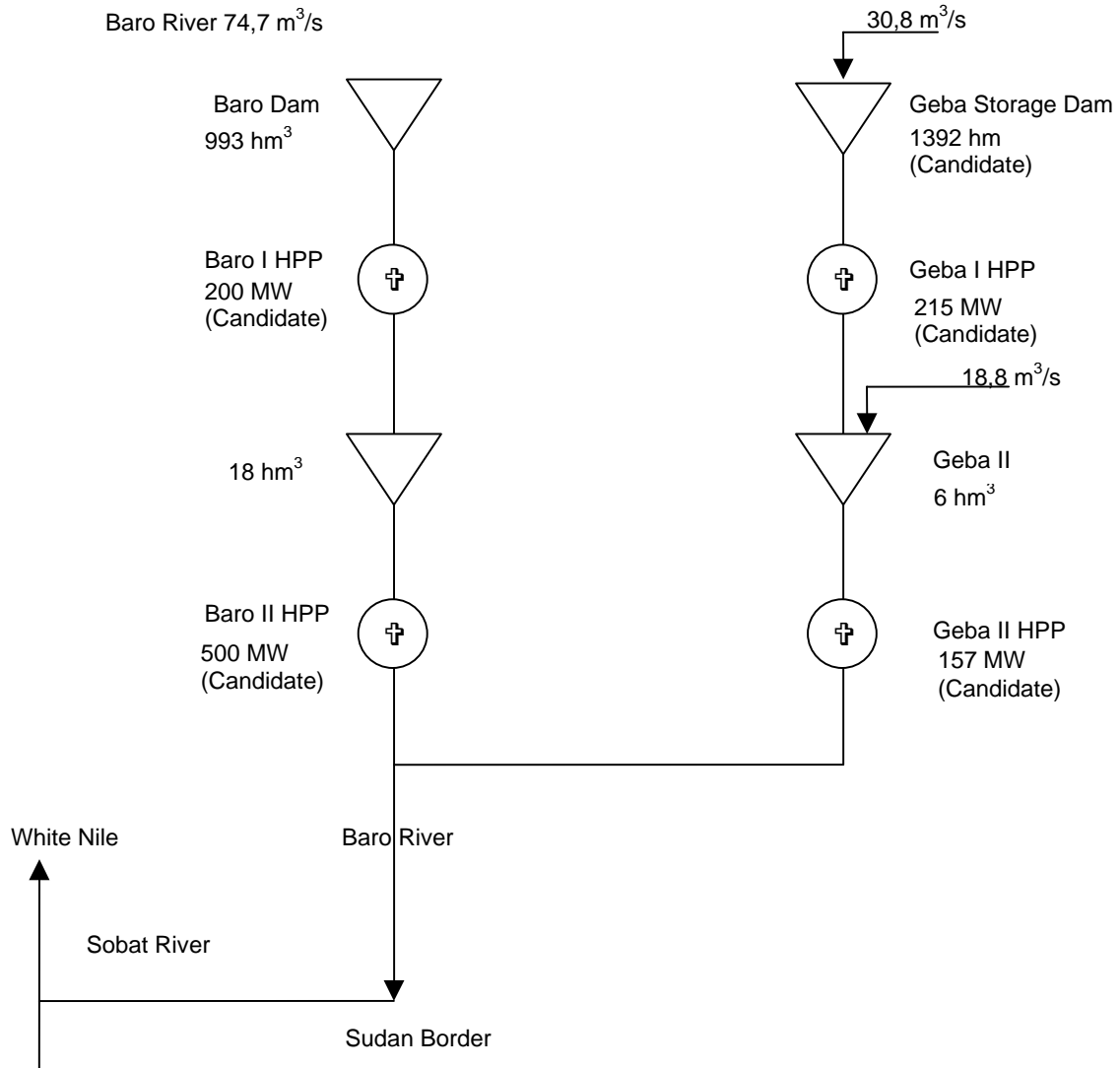
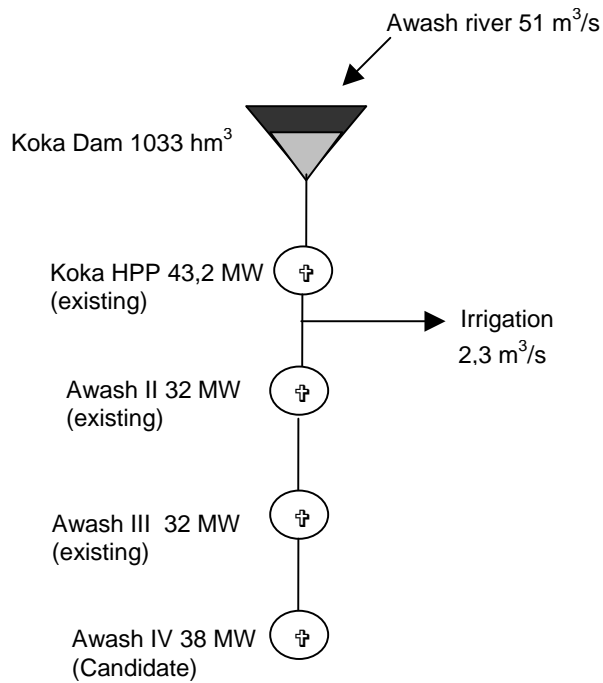

Figure 6.2-7 - Schematic configuration of Baro River system



AWASH RIVER

(Infiltration & evaporation)

Figure 6.2-8 - Schematic configuration of Zoom Awash River system

Module M3: Energy Sector Profile & Projections

VOL 3: ETHIOPIA

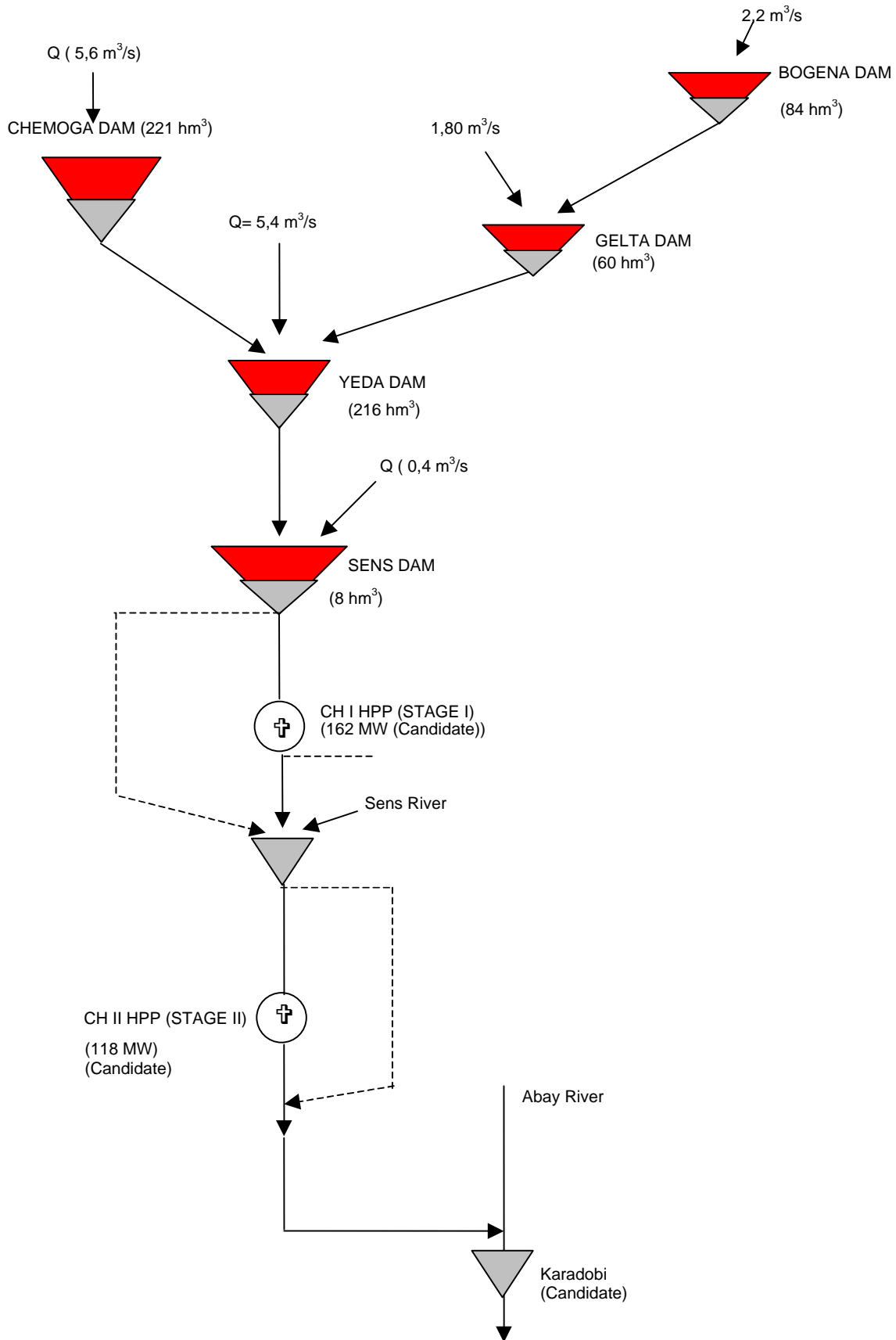

Figure 6.2-9 - Schematic configuration of Chemoga Yeda system

Module M3: Energy Sector Profile & Projections

VOL 3: ETHIOPIA

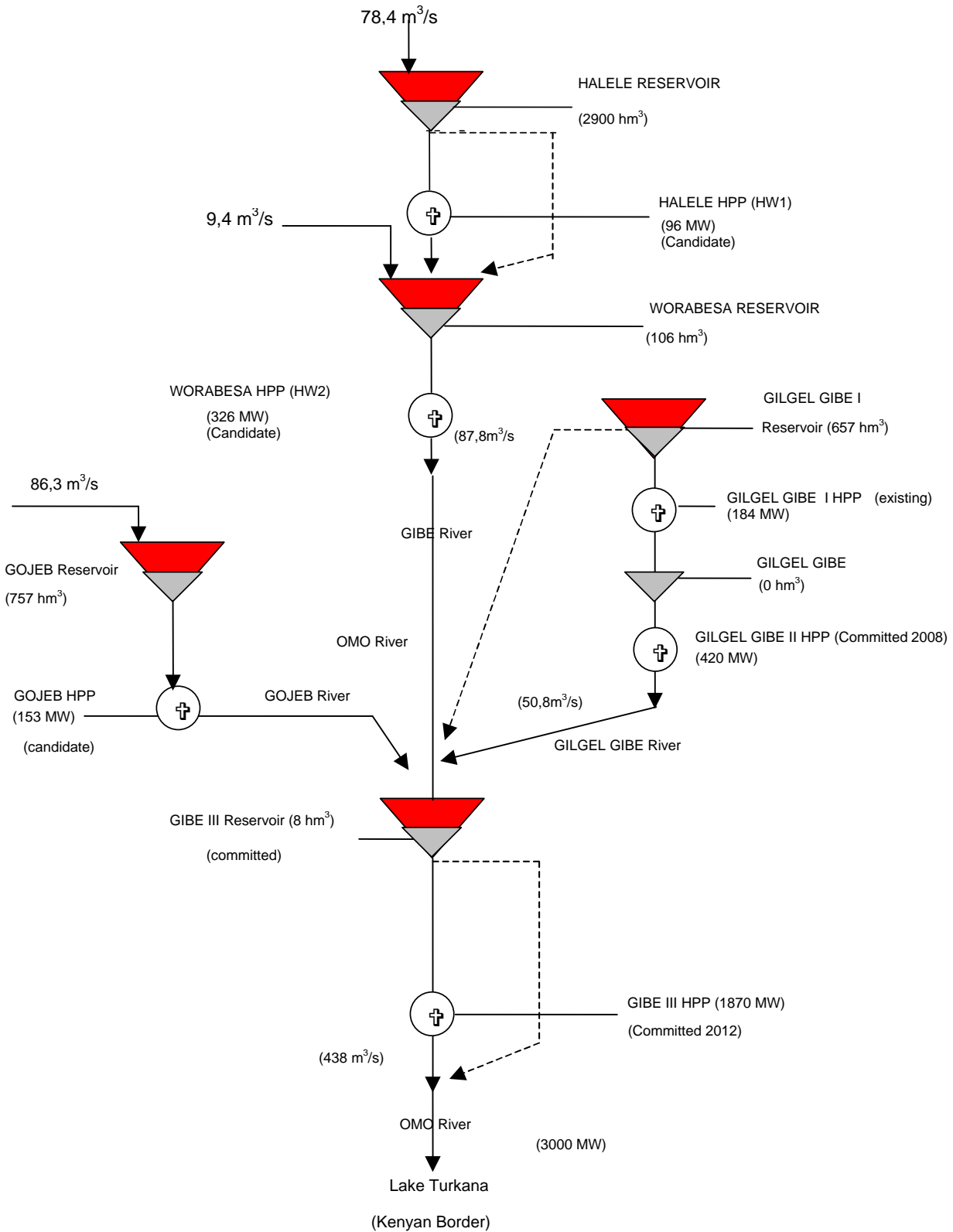

Figure 6.2-10 - Schematic configuration of Omo river system

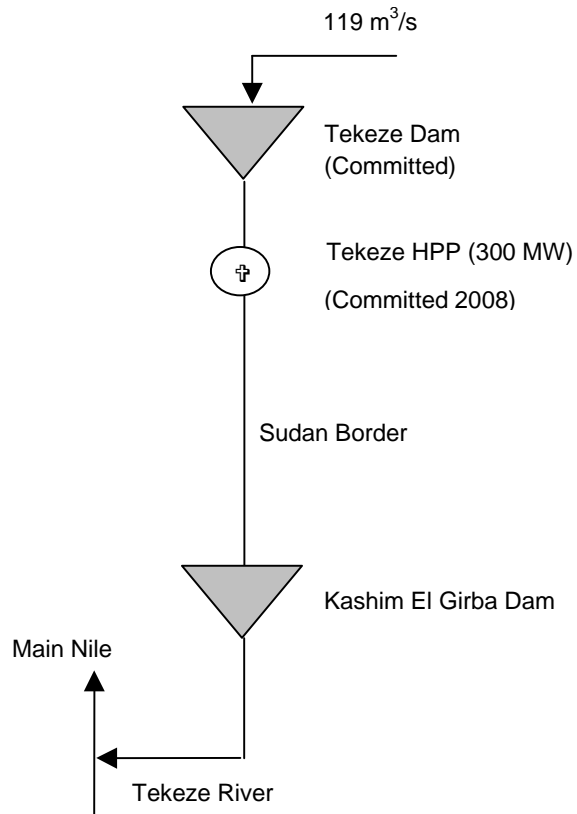

Figure 6.2-11 - Schematic configuration of Tekeze System

6.3 OTHER TYPES OF POWER CANDIDATES (GEOTHERMAL, WIND, SOLAR, ETC)

6.3.1 GEOTHERMAL GENERATION RESOURCES

6.3.1.1 Introduction

Ethiopia is among the few countries in Africa with significant geothermal resources.

These resources are found scattered throughout the Ethiopian Rift Valley and in the Afar Depression, which are both part of the Great East African Rift system. The Ethiopian rift extends from Kenya to the Red Sea from over 1,000 km within Ethiopia and covers an area of 150,000 km². Ethiopia launched a long-term exploration program in 1969 and today a total of 16 geothermal resources areas have been identified by various studies. The geothermal generation potential is certainly considerable, and it is possible that generation resources can contribute significantly in the future to the country's needs. The possible energy reserve can be estimated today at about 2,500 MW.

The main identified geothermal prospect areas are:

- In the Lakes District about 100 to 300 km from Addis Ababa; the Aluto Volcanic Center just north of lake Langano has been identified as the most attractive prospect.
- A total of eleven areas in the Southern Afar region between Tulu-Moye in the south and Tendaho in the north.
- Two areas in the Danakil Depression in the Northwest Afars area.

These geothermal prospects are at different levels of study; the Aluto and Tendaho fields are at an advanced exploration stage.

Geothermal power is suitable for producing base load contributions to the ICS (or to the local SCS if the transmission line cost is too expensive). The total capital cost for small geothermal facilities is estimated at between \$2,500 and \$3,500/kWh with an O&M cost of \$50/60/kW/yr which give an attractive generation cost of about \$50/70/MWh for a base load utilisation (7,000 hours).

6.3.1.2 The Aluto-Langano geothermal field

The **Aluto-Langano** geothermal site is located in the "Aluto Volcanic Complex" about 200 km south of Addis Ababa between the lakes of Ziway and Langano.

A 7.3 MW pilot geothermal power plant was installed and completed in 1999 but today the plant is out of service due to technical limitations and energy generation is not expected by EEPCO before 2007.

The site could be further developed in two stages for an additional 30 MW of new capacity based on an "Electroconsult" assessment (feasibility study in 1986).

6.3.1.3 The Tendaho geothermal field

The **Tendaho** geothermal site is located some 400 km north east of Addis Ababa and comprises an area with a usable capacity of approximately 500 km². The field is considered as the best site for large-scale geothermal energy development in Ethiopia. The possible potential will be estimated at about 1,000/1,500 MW on the basis of 100 km² area and a normative output of 10/15 MW/km².

The further power plant proposed by EEPCO is a 3 to 5 MW steam turbine plant (connected to the local SCS).

6.3.1.4 Hypothesis for the study

Considering the uncertainties and the relative small capacities involved, no thermal project will be considered in the economic study (Module 6).

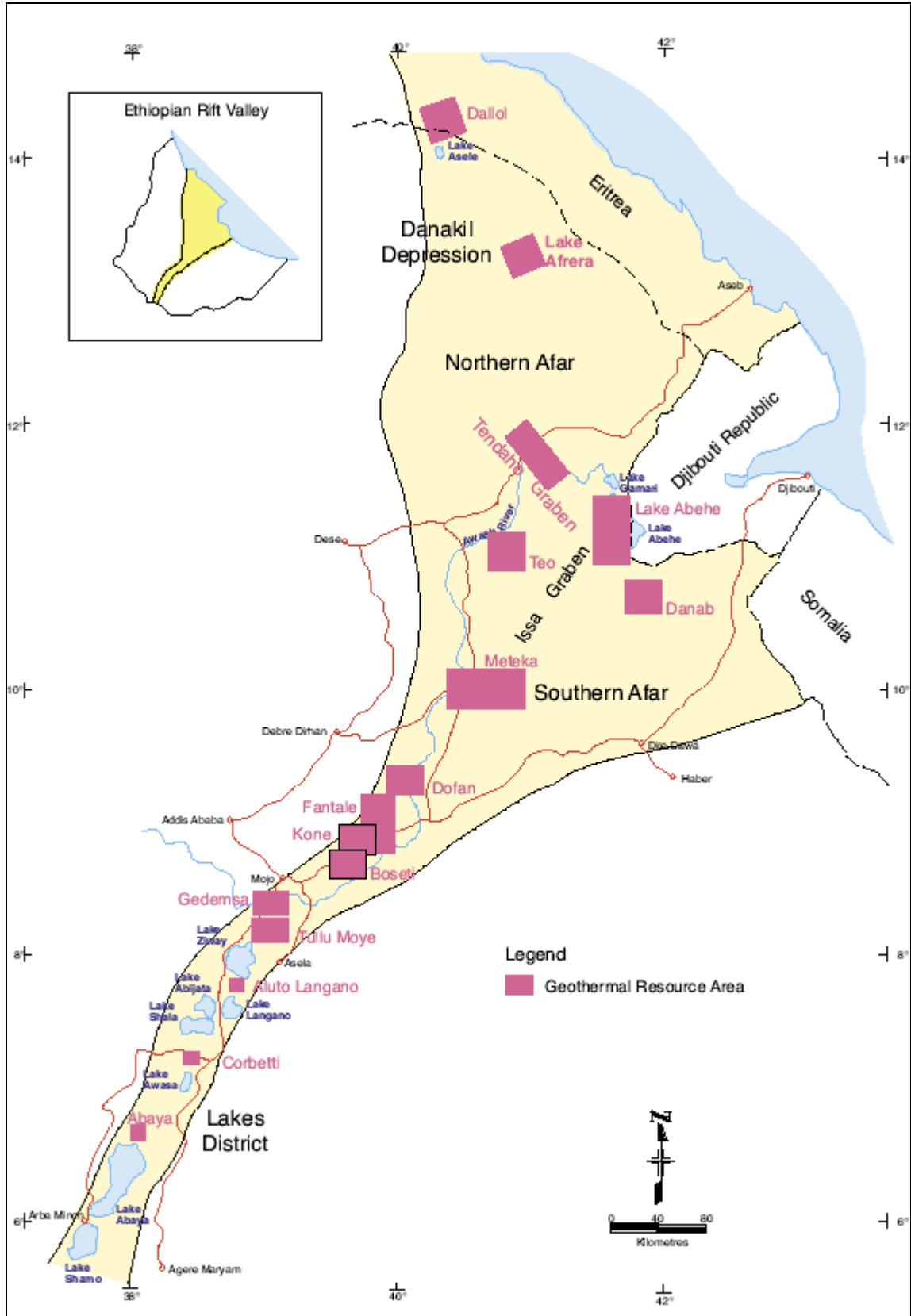

Figure 6.3-1 - Geothermal prospect areas within Ethiopian Rift valley

6.3.2 WIND GENERATION RESOURCES

EEPSCO is embarking on an investigation of its potential and a 50 MW-wind park feasibility study has been committed with an expected commissioning date between 2009 and 2010.

But the greatest proportion of wind energy (see the national atlas of Ethiopia) appears to be in the rainy season between June and September, thus coinciding with the period of greatest hydropower potential.

The construction cost for a 50MW wind park is estimated at about \$75M (\$1,500/kW). With a 35% plant factor it is possible to produce non-guaranteed energy at approximately \$80 /MWh, which is not very competitive in comparison with hydro generation or traditional thermal resources. This alternative energy resource could be attractive, especially for Independent Power Producers, if it is possible to be connected to the grid without excessive expenditure.

No wind generation project will be considered in the economic study (Module 6).

6.3.3 SOLAR GENERATION RESOURCES

Concerning solar energy, while ideal for some specific applications, it is not generally economically competitive.

For the moment these resources are not appropriate to meet the country's future needs.

No wind generation project will be considered in the economic study (Module 6).

7. REVIEW OF THE EXISTING GENERATION EXPANSION PLAN

Taking into account the reliability and system reserve criteria, and on the basis of meeting the target demand forecast, EEPSCO updated in June 2006 the generation expansion plan previously developed by ACRES and established the schedule for implementation of new generating plant and transmission expansion.

The summary of this updated plan is as follows:

Year	Plant	N° of units x Capacity	System Dependable capacity (MW)	ICS Peak Demand - Medium scenario (MW)	ICS Peak Demand - Target scenario (MW)	Margin ratio for Target Demand scenario
2008	GILGEL GIBE II	4 x 105	1 135			
2008	TEKEZE	4 x 75	1 435	826	900	59%
2009	BELES	4 x 105	1 855	967	1 079	72%
2010	YAYU COAL	2 X 50	1 955	1 125	1 286	52%
2011	GIBE III (Phase 1)	4 x 226	2 857	1 266	1 485	92%
2012	GIBE III (Phase 2)	4 x 226	3 759	1 418	1 705	120%
2013						
2014	HALELE WORABESA	2 x 48,5 + 4 x 81,5	4 181	1 765	2 229	88%
2015	CHEMOGA YEDA	2 x 81 + 2 x 59	4 461	1 967	2 544	75%

Table 6.3-1 - EPSEMPU generation expansion plan (June 2006)

It can be noticed that the system dependable capacity is significantly greater than the target peak demand projection which results in good opportunities for power exports to neighbouring countries.

Wind and geothermal power is considered in the EEPSCO investment program (EPSEMPU June 2006) and the plants recommended between 2010 and 2015 are mainly:

- The geothermal rehabilitation of **Aluto-Langano** in 2007,
- The **Tendaho** geothermal plant (3/5 MW) after 2011 connected to the SCS,
- The **Wind Park** (50 MW) after 2011.

Module M3: Energy Sector Profile & Projections

VOL 3: ETHIOPIA

The investment schedule for the GEP (medium term 2006 – 2015) is as follows:

On Line Year	Generation Project	Capital Cost (\$x10 ^{^16})	YEAR									
			2006	2007	2008	2009	2010	2011	2012	2013	2014	2015
2006												
2007	Geothermal Rehab	Under Rehabilitation										
2008	Gilgel Gibe II Tekeze	Under Construction										
2009	Beles	Under Construction										
2010	Yayu Coal	175,3	Committed	58,43	58,43	58,43						
2011	Gilgel Gibe III - 1 st 5 Units	957,3		239,325	239,325	239,325	239,3					
2012	Gilgel Gibe III - 2 nd 5 Units	410,3			102,575	102,575	102,6	102,6				
2013							118,5	118,5	118,5	118,5		
2014	Halele Worabesa	474						97,8	97,8	97,8	97,8	
2015	Chemoga Yeda	391,2										
Total Annual Investments		2408,1		297,8	400,3	400,3	460,4	318,9	216,3	216,3	97,8	0,0

Table 7-6.3-2 - EPSEMPU investment schedule

The generation plan would also incorporate in long term:

- other hydro power plants such as Geba, Genale, Baro, Calub, Gilgel Gibe IV, Karadobi, Gojeb, Aleltu, Mandaya and Border (see table here after), other wind parks and geothermal plant.

Module M3: Energy Sector Profile & Projections

VOL 3: ETHIOPIA

	Capacity (MW)	Annual Energy (GWh/yr)		Estimated Unit Energy Cost (\$/kWh)	
		Average	Firm	Average	Firm
HYDRO-ELECTRIC					
<u>Short-Listed</u>					
Gilgel Gibe II	420	1 903	1 504	0.0269	0.0340
Gibe III	1 800	6 000	-	0.0339	
Gigel Gibe IV	2 000	7 500	-	-	
<u>Chemoga Yeda</u>	207	1 391	876	0.0367	0.0400
<u>Halele-Worabesa</u>	435	2 233	1 699	0.0311	-
Beles	420	2 142	1 855	0.0285	-
Awash IV	34	192	170	0.0218	0.0246
Neshe	43	223	220	0.0291	0.0295
Gojeb	150	528	476	0.0534	0.0592
Aleltu West	265	1 051	981	0.0434	0.0405
Aleltu East	189	657	631	0.0540	0.0519
Subtotal	5 963	23 820	8 412		
<u>Others</u>					
<u>Genale</u>	605	2 832	2 285	0.028	-
<u>Geba</u>					
Stage 2	101	745	823	0.0298	0.0270
Stages 2 & 1	259	1 682	1 734	0.0225	0.0218
<u>Baro</u>					
Stage 1	166	727	464	0.0681	0.1067
Stages 1 & 2	645	2 786	1 752	0.0357	0.0568
Subtotal	1 776	8 772	7 058		
TOTAL HYDRO	7 739	32 592	15 470		

Table 7-6.3-3 - Potential Generation Resources

It is important to notice that:

- the above table does not include all potential project (some large one such as Karadobi, Mabil, Mandaya and Border are missing),
- no screening/selection neither commissioning date are proposed.

The main assumptions used in the GEP were a discount rate of 12% and a economic cost of unserved energy of 0,52 USD/kWh.

8. REVIEW OF THE EXISTING TRANSMISSION MASTER PLAN

(See Ethiopian Power System Expansion Master Plan update June 2006)

Existing transmission system in 2006

The existing transmission system consists of 6 534 km of transmission lines, of which 1 716 km are at 230 kV level, 2 561 km at 132 kV level, 1 782 km at 66 kV and 476 km at the 45 kV levels respectively. The SOR hydro plant supplies an SCS small system at 66 kV while other such systems are supplied from diesel generation plants. There are a total of 107 substations in the system, of which 11 are at 230 kV, 45 at 132 kV, 26 at 66 kV, and 23 at 45 kV level.

Committed Transmission Installations

Connection of new dams

The 400 kV transmission lines, to evacuate the generation of the new Gilgel Gibe II dam (420 MW), to Gilgel Gibe I and to Sebeta, are already under construction. A double-circuit 230 kV transmission line from Tekeze (new 300 MW dam) to Mekele is under construction.

Network reinforcement

The second circuit Finchaa - Ghedo - Gefersa 230 kV (securing Finchaa hydro plant) and the Alamata - Kombolcha - Kality I 230 kV line (for the exportation of Tekeze generation, closing the 230 kV loop in the north of Ethiopia) are in procurement stages.

The 132 kV lines from Dire Dawa to Jijiga, Yirga Alem to Hagera Mariam, Ghimbi to Assosa, and Wolayita Sodo to Sawla are completed or are at the final stage of the construction phase.

Network extension

A 230 kV single line from Gonder to Metama is under construction, and a 230 kV Kombolcha - Samera - Dichato line is in procurement stages

Transmission master plan (see **Table 6.3-2** and **Table 6.3-3**)

The master plan provides a detailed planning of the new equipment commissioning up to 2015.

A 400 kV double circuit transmission line from Beles (new 460 MW hydro plant) to a new sub station near Bahar Dar, followed by a single circuit transmission to Sululta (north of Addis Ababa) via Debre Markos (total length of 495 km) is planned.

The other 400 kV circuits planned are dedicated to evacuate the generation of Gibe III (1 800 MW, phase 1 planned for 2011, phase 2 the year after) to Addis Ababa, one single circuit to Gilgel Gibe II and a double circuit to Kilati, via W. Sodo.

The north 400 kV circuit (Beles - Bahar Dar - Debre Markos - Sululta) and the south one (Gilgel Gibe I - GG II - G III - W. Sodo - Kilati - Sabata) are connected via Addis Ababa 230 kV circuit (Kilati to Sululta, via Sabata).

Module M3: Energy Sector Profile & Projections

VOL 3: ETHIOPIA

An 230 kV circuit on the west side of Ethiopia from Gambela to Bedele will be built with the commissioning of the Yayu coal plant in 2010. It is connected to the rest of the system via the 132 kV level, with the 220/132 kV substation in Bedele, to Gilgel Gibe I.

The 230 kV system will be extended:

- to the west, as mentioned above;
- to the south-east part of Ethiopia, from Melka-Wakana to Gode via Ramos (around 600 km);
- to the north-east part of the country, from Kembolcha to Dichato (close to the northern Djiboutian border) via Samara (243 km);
- to the north-west part of the country, from Tekeze and Gonder to Humera (close to the border of the 3 countries: Ethiopia - Sudan - Eritrea).

Including the above mentioned lines, the master plan report shows that between the years 2006-2015 the following will be constructed.

Voltage level (kV)	Length (km)
400	1 210
230	3 486
132	1 845
66	305
Total	6 846

Table 6.3-1 - Projected lines from 2006 to 2015.

The master plan does not take into account the Mandaya or Border hydro candidates. The development of such project will impact the development of generation, and therefore the network master plan.

Planned interconnections

The feasibility studies for the interconnection projects with Djibouti (283 km of single 230 kV circuit, from Dire Dawa to PK-12 - export of 50 MW) and with Sudan (194 km of double 230 kV circuit, from Shehedi to Gedaref - maximum export of 200 MW) have been carried out. EEPKO and NEC agreed to complete their interconnection line by February 2008. The Ethiopian-Djibouti interconnection is at the initial stage of preparation for construction.

The determination of the Ethio-Kenyan interconnection project route and components is part of the objectives of the upcoming feasibility study. Preliminary assessments made by EEPKO indicate that because of the distance between the generations in Ethiopia and load centres in Kenya HVDC link which runs from Mega in Ethiopia to Eldorate or Nairobi in Kenya will be part of the project. AC 400 kV lines from Gibe III will feed this HVDC at Mega. Possible future generations at Genale could also be connected to the Mega converter station to supplement the export.

Module M3: Energy Sector Profile & Projections

VOL 3: ETHIOPIA

	From	To	Voltage Level	km	In Service Year	Status	Remark
1	Shakiso	Negele	66	115	2006	U.C	Committed
2	Melkawakena	Gobessa	66	75	2006	U.C	Committed
3	Jimma	Bonga	132	102	2006	U.C	Committed
4	Bonga	Mizan	132	88.3	2006	U.C	Committed
5	Mizan	Tepi	66	30.6	2006	U.C	Committed
6	Wolayita	Sawla	132	123.6	2007	U.C	Committed
7	Yergaalem	Dilla II	132	40	2007	U.C	Committed
8	Dilla II	H/Mariam	132	90	2007	U.C	Committed
9	Ghimbi	Mendi	132	117	2007	U.C	Committed
10	Mendi	Assossa	66	84	2007	U.C	Committed
11	Jimma	Aba	132	47	2007	U.C	Committed
12	Nekemte	Bedele	132	116	2007	U.C	Committed
13	Kombolcha	Aksta	132	82	2008	U.C	Committed
14	Tekeze	Mekele	2x230	90	2008	U.C	Committed
15	Mekele	Alamata	230	141	2008	U.C	Committed
16	Alamata	Combolcha	230	121	2008	U.C	Committed
17	Combolcha	Cotebe	230	294	2008	U.C	Committed
18	Cotebe	Kality	230	20	2008	U.C	Committed
19	Finchaa	Ghedo	230	93.6	2008	U.C	Planned
20	Ghedo	Gefersa	230	134	2008	U.C	Planned
21	Combolcha	Samara	230	180	2008	U.C	Planned
22	Samara	Ditchato	230	63	2008	U.C	Planned
23	Gonder	Shehidi	2x230	135	2008	U.C	Planned
24	Gilgel Gibe II	Gilgel Gibe I	400	30	2008	Design	Planned
25	Gilgel Gibe II	Sabata II	400	185	2008	Design	Planned
26	Sebeta II	Sebeta I	2x230	20	2008	Design	Planned
27	Gonder	Humera	230	323	2008	Design	Planned
28	Beles	Bahar Dar III	2x400	65	2009	Design	Planned
29	Bahar Dar III	Debremarkos	400	200	2009	Design	Planned
30	D.Markos	Sululta	400	230	2009	Design	Planned
31	Sululta	Cotebe	2x230	30	2009	Design	Planned
32	Tekeze	E/Selase	230	249	2009	Design	Planned
33	E/Selase	Humera	230	285	2009		Planned
34	Melka Wakena	Ramo	230	287.5	2009		Planned

Module M3: Energy Sector Profile & Projections

VOL 3: ETHIOPIA

35	Ramo	Gode	230	325	2009		Planned
36	Melkawakena	Yadot	132	100	2009		Planned
37	Dire Dawa	Dj. Border	230	201	2009		Planned
38	Ramo	Fik	132	250	2009		Planned
39	Sawla	KeyAfer	132	120	2009		Planned
40	Hagere Mariam	Mega	132	170	2009		Planned
41	Addis Nort Tap	Addis North	230	5	2009		Reinforcement
42	Aksta	Alem Ketema	132	100	2009		Planned
43	Nekemte	Gutin	132	67	2009		Planned
44	Bedele	Yayu Coal	230	48	2010		Planned
45	Yayu	Metu	230	42	2010		Planned
46	Bedele	Metu	230	90	2010		Planned
47	Metu	Gambela	230	150	2010		Planned
48	Kaliti I	Addis Center	132	14	2010		Reinforcement
49	Cotebel	Cotebell	132	10	2010		Reinforcement
50	GGIII	W.Sodo	2x400	80	2011		Planned
51	W.Sodo	Kalityl	2x401	270	2011		Planned
52	GGIII	GGII	1x400	150	2011		Planned
53	Kality I	Kality North	132	3	2011		Reinforcement
54	Kality I	Bole Weregenu	132	19	2011		Reinforcement
55	Halele	Worabesa	1x230	30	2014		Planned
56	Werabessa	Worabesa Tap	2x230	5	2014		Planned
57	Worabesa	Ghedo	230	79	2014		Planned
58	Yirgalem	W.Sodo	132	60	2015		Reinforcement
59	G.Gibe old	Jimma	132	71	2015		Reinforcement
60	Mesobo	Mekele	132	25	2015		Reinforcement
61	Kality I	D.Zeit	132	30	2015		Reinforcement
62	Chemoga Yeda 1	D.Markos	2x230	36	2015		Planned
63	Chemoga Yeda 2	Chemoga Yeda 1	1x230	9	2015		Planned

Table 6.3-2 - Planned Transmission Line Additions

Module M3: Energy Sector Profile & Projections

VOL 3: ETHIOPIA

No.	Connection Point	Voltage Level	Status	In Service Year
1	Addis South II S/S	132/15	U.C	2006
2	Nazareth II S/S	132/33	U.C	2006
3	Mota	230/33	U.C	2006
4	Addis East II	132/15	U.C	2006
5	Negele	66/33	U.C	2006
6	Harar III	132/66/33	U.C	2006
7	Jijiga II	132/66/33	U.C	2006
8	Gobessa	66/33	U.C	2006
9	Bonga	132/33	U.C	2006
10	Mizan	132/33	U.C	2006
11	Tepi	66/33	U.C	2006
12	Nifas Mewcha	230/33	U.C	2006
13	Gashena	230/33	U.C	2006
14	Sawla	132/66/33	U.C	2007
15	H.Mariam	132/33	U.C	2007
16	Dilla II	132/66/33	U.C	2007
17	Mendi	132/66/33	U.C	2007
18	Assosa	66/33	U.C	2007
19	Aba	132	U.C	2007
20	Combolcha II	230/132		2008
21	Cotebe II	230/132		2008
22	Shehedi	230/33	U.C	2008
23	Sebeta II	400/230	Design	2008
24	Humera	230/33	Design	2008
25	Samara	230/33	U.C	2008
26	Dichato	230/33	U.C	2008
27	Aksta	132/66/33	U.C	2008
28	Gilgel Gibe II	400		2008
29	Tekeze	230		2008
30	Beles	400		2009
31	B. Dar III	400/230		2009
32	Sululta	400/230/33	Design	2009
33	E/Selase	230/66/33	Design	2009

Module M3: Energy Sector Profile & Projections

VOL 3: ETHIOPIA

34	Ramo	230/132/33		2009
35	Ghedo	230/132/33		2009
36	Fik	132/33		2009
37	Yadot	132/33		2009
38	KeyAfer	132/33		2009
39	Mega	132/33		2009
40	Alemketema	132/33		2009
41	Gutin	132/33		2009
42	Yayu	230		2010
43	Gibe III	400		2011
44	Halele	230		2014
45	Worabesa	230		2014
46	Chemoga Yeda I	230		2015
47	Chemoga Yeda II	230		2015

Table 6.3-3 - New Substations



ENTRO



EDF – Generation and Engineering
Division
73 373
Le Bourget du Lac Cedex
France
Tel: +33-4-79 60 60 28
Fax: +33-4-79 60 62 35
eMail: pierre.brun@edf.fr
<http://www.edf.fr>

EASTERN NILE POWER TRADE PROGRAM STUDY

AfDB



Scott Wilson
Kanthack House, Station Road,
Ashford, Kent TN 23 1 PP
England
Tel: +44 (0) 1233 658200
Fax: +44 (0) 1233 658209
eMail: alan.bates@scottwilson.com
<http://www.scottwilson.com>

ENERGY SECTOR PROFILE & PROJECTIONS

VOL 3 - ETHIOPIA

with participation of:

- EPS (Egypt)
- Tropics (Ethiopia)
- YAM (Sudan)

FINAL APPENDIX

June 2007



TABLE OF CONTENTS

1	CHARACTERISTICS OF HPP CANDIDATES	5
2	EVAPORATION DATA.....	8
3	HISTORIC EVOLUTION OF GDP	8
4	HISTORIC SALES, GENERATION AND PEAK DEMAND	8
5	MONTHLY LOAD DURATION CURVES.....	9
6	ICS FORECAST MODERATE SCENARIO	11
7	SCS FORECAST MODERATE SCENARIO	11
8	ICS FORECAST TARGET SCENARIO	11
9	SCS FORECAST TARGET	11
10	ICS LOW TARGET SCENARIO	11
11	LOW DEMAND SCENARIO	11
11.1	FORECAST ASSUMPTIONS FOR THE LOW SCENARIO	11
11.1.1	Overview.....	11
11.1.2	Tariff evolution	12
11.1.3	Customers Growth.....	12
11.1.4	Rural Electrification Approach	14
11.2	ASSUMPTIONS IDENTICAL FOR TARGET, MODERATE AND LOW SCENARIO	14
11.2.1	Economic Growth	14
11.2.2	Rural Electrification.....	15
11.2.3	SCS centers transfered to the ICS withing the study period.....	16
11.2.4	Self-Contains SYSTEM (SCS)	17
11.2.5	Income and price elasticity	18
11.2.6	Street Lighting Sales	18
11.2.7	Generation and Power Demand Forecast.....	18
11.3	FORECAST RESULTS.....	18

Module 3: Energy Sector Profile and Projections

Vol 3: Ethiopia

LIST OF TABLES

TABLE 1-1 - POWER PLANT PRINCIPAL CHARACTERISTICS AT PROPOSED ETHIOPIAN SITES.....	7
TABLE 2-1 - EVAPORATION NET LOSS (MM).....	8
TABLE 11-1 - DIFFERENCES OF HYPOTHESIS FROM THE EEPKO MEDIUM SCENARIO	12
TABLE 11-2 - EEPKO'S EXISTING SYSTEM NUMBER OF CUSTOMERS GROWTH ASSUMPTIONS	13
TABLE 11-3 - LOW DEMAND SCENARIO EXISTING SYSTEM NUMBER OF CUSTOMERS GROWTH ASSUMPTIONS	14
TABLE 11-4 - GDP GROWTH RATES FOR THE LOW AND MODERATE SCENARIO.....	15
TABLE 11-5 - SCHEDULE FOR TRANSFER OF SCS CENTRES TO ICS	17

LIST OF FIGURES

FIGURE 11.1-1 - MONTHLY LOAD DURATION CURVES 9
FIGURE 11.3-1 - EEPCO 2006 ENERGY AND PEAK DEMAND FORECAST INTER CONNECTED SYSTEM (ICS) 19

1 CHARACTERISTICS OF HPP CANDIDATES

Origin: RAPSO modelling

Module 3: Energy Sector Profile and Projections

Vol 3: Ethiopia

Reservoir characteristics at proposed Ethiopian sites

Karadobi				Mandaya									Border													
				860			800			741			580			578										
Level (m)	Volume (Mm ³)	Area (km ²)	Spill capacity (m ³ /s)	Level (m)	Volume (Mm ³)	Area (km ²)	Level (m)	Volume (Mm ³)	Area (km ²)	Level (m)	Volume (Mm ³)	Area (km ²)	Level (m)	Volume (Mm ³)	Area (km ²)	Level (m)	Volume (Mm ³)	Area (km ²)								
Detailed	900	0	0	Detailed	610	0	0	Detailed	610	0	0	Detailed	610	0	0	Detailed	520	100	24	Detailed	520	100	24			
	920	4	0.65		620	30	6		620	30	6		620	30	6		530	550	68		530	550	68			
	940	93	10.2		630	140	16		630	140	16		630	140	16		540	1350	116		540	1350	116			
	960	466	28.6		640	358	27.6		640	358	27.6		640	358	27.6		550	2850	192		550	2850	192			
	980	1383	65.7		650	716	44		650	716	44		650	716	44		Act	560	5300		288	Act	560	5300	288	
	1000	3117	110		660	1256	64		660	1256	64		660	1256	64	570		8650	416	570	8650		416			
	1020	5605	140		Detailed	670	2011		87	Detailed	670		2011	87	Detailed	670	2011	87	Detailed	577.5	12100	534.5	Detailed	577.5	12100	534.5
	1040	8703	170			680	3006		112		680		3006	112		680	3006	112		580	13250	574		577.5	12100	534.5
	1060	12520	212			690	4286		144		690		4286	144		690	4286	144								
	1080	17189	256			700	5881		175		700		5881	175		700	5881	175								
Act	1100	22799	306	710		7771	203	Act	710		7771	203	Act	710		7771	203									
	1120	29479	363	720		9946	232		720		9946	232		720		9946	232									
	1140	37338	424	730		12486	276		730		12486	276		724.8		11165	253.1									
	1146	40094	445	740		15781	383		740		15781	383		730		12486	276									
	1147	40553	449	16983		741	16223		389		741	16223		389		740	15781	383								
	1148	41012	452	18441		760	24614		500		760	24614		500		741	16223	389								
	1150	41931	460	21454	780	35727	611		780	35727	611															
	1151	42390	463	23343	800	49201	736		800	49201	736															
	1153	43309	470	27945	Act	820	65318		875																	
	1153.8	43681	473	30022		840	84303		1023																	
				860	106728	1219																				
Sources	Lahmeyer International			Scott Wilson 2006						USBR 1964			Scott Wilson 2006			USBR 1964										

Module 3: Energy Sector Profile and Projections

Vol 3: Ethiopia

Power plant principal characteristics at proposed Ethiopian sites

	Karadobi		Mandaya						Border			
			860		800		741		580		578	
Maximum capacity (MW)	8 x 200	1 600	8 x 300	2 400	8 x 250	2 000	12 x 135	1 620	6 x 200	1 200	14 x 100	1 400
Maximum discharge (m ³ /s)	884		1207		1337		1588		1706		168	
Level / Energy coefficient : -	Level	Coefficient	Level	Coefficient	Level	Coefficient	Level	Coefficient	Level	Coefficient	Level	Coefficient
	(m)	(m ³ /s/MW)	(m)	(m ³ /s/MW)	(m)	(m ³ /s/MW)	(m)	(m ³ /s/MW)	(m)	(m ³ /s/MW)	(m)	(m ³ /s/MW)
	1100	0.6581	820	0.5748	760	0.8122	725	1.0888	560	1.9283	569.5	1.6476
	1123	0.5778	840	0.5241	780	0.7096	733	1.0199	570	1.6167	573.5	1.5714
	1146	0.5143	860	0.4762	800	0.6340	741	0.9457	580	1.4215	577.5	1.4714
Sources	Lahmeyer International		Scott Wilson 2006			USBR 1964		Scott Wilson 2006		USBR 1964		

Table 1-1 - Power plant principal characteristics at proposed Ethiopian sites

2 EVAPORATION DATA

Origin : RAPSO modeling

Evaporation net loss (mm)

Site Elevation (masl)	Karadobi 1146	Mandaya			Border 580
		860	800	740	
Jan	176	191	193	195	201
Feb	169	182	184	186	192
Mar	140	146	147	149	159
Apr	131	134	136	137	148
May	101	104	105	107	117
Jun	-15	-22	-21	-20	-8
Jul	-200	-219	-219	-219	-188
Aug	-181	-151	-150	-150	-122
Sep	-28	17	17	18	31
Oct	82	116	118	119	127
Nov	126	147	148	149	155
Dec	161	179	180	182	187
Annual	662	823	837	852	1000
Source	Lahmeyer International	Scott Wilson 2006			

Table 2-1 - Evaporation net loss (mm)

3 HISTORIC EVOLUTION OF GDP

See Appendix M3-Vol3-3 Table 1

4 HISTORIC SALES, GENERATION AND PEAK DEMAND

See Appendix M3-Vol3-3 Table 2

5 MONTHLY LOAD DURATION CURVES

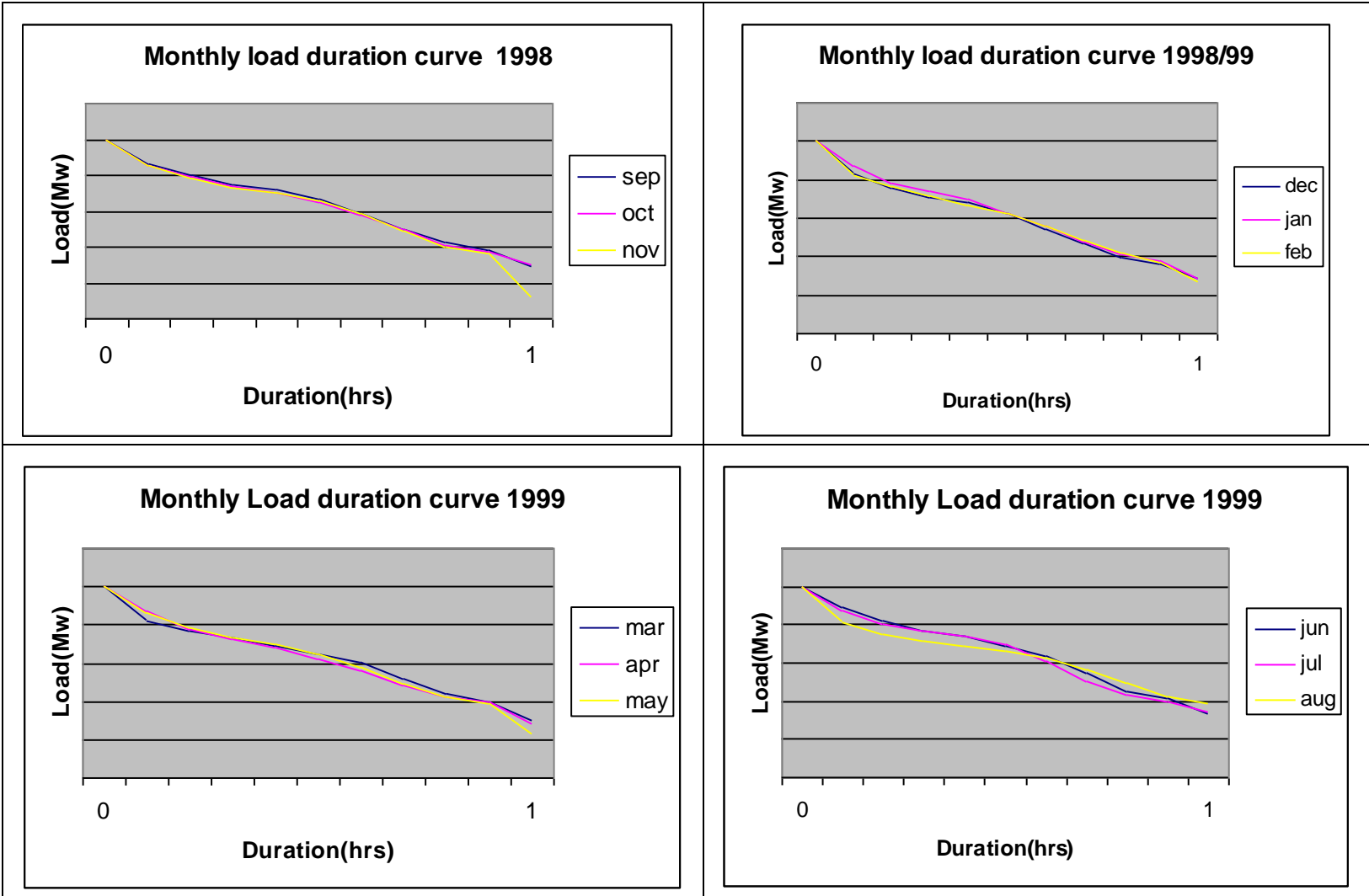

Figure 11.1-1 - Monthly load duration curves

6 ICS FORECAST MODERATE SCENARIO

See Appendix M3-Vol3-3 – Table 3

7 SCS FORECAST MODERATE SCENARIO

See Appendix M3-Vol3-3 – Table 4

8 ICS FORECAST TARGET SCENARIO

See Appendix M3-Vol3-3 – Table 5

9 SCS FORECAST TARGET

See Appendix M3-Vol3-3 – Table 6

10 ICS LOW TARGET SCENARIO

See Appendix M3-Vol3-3 – Table 7

11 LOW DEMAND SCENARIO

11.1 FORECAST ASSUMPTIONS FOR THE LOW SCENARIO

11.1.1 OVERVIEW

The methodology and the forecast models used by the Consultant to forecast the low scenario demand are the same as used by EEPCO for the Target and Moderate scenarios.

The differences of hypothesis from the EEPCO medium scenario are listed in the table below:

Module 3: Energy Sector Profile and Projections

Vol 3: Ethiopia

Assumption	EEPCO medium scenario	New scenario
50% access to electricity	in 5 years	in 15 years
Tariffs	+ 16% (in 2007)	+ 25% (10% in 2008 and 2009, +5% in 2010)
Number of customers	+150 000 in 2006 + 450 000 in the first 5 years +3% per year from 2018 (population growth rate)	+ 130 000 in 2006 +280 000 in the first five years +3% per year from 2018 population growth rate)

Table 11-1 - Differences of hypothesis from the EEPCO medium scenario

11.1.2 TARIFF EVOLUTION

EEPCO's forecast assumes a one time 16% price increment to be effective on 2007. This is reasonable and in reality EEPCO has already made a 22% increment that is made effective on July 2006 (beginning of fiscal year 2007). Now EEPCO's nominal tariff is back to 6 USD cents level, which has been reducing due to exchange rate variations.

In the future additional adjustments are required in order to place EEPCO at financially sound position, so that it can appropriately cover its future capital and operating costs. The original master plan study conducted by ACRES has indicated a cost recovery tariff of 7.5 USD cents based on the investments anticipated at that time.

For the Low scenario forecast, it is assumed that EEPCO's tariff will reach 7.5 USD cents by 2010. This will be a 25% increment and is assumed to be implemented at three stages with 10% increment in 2008 and 2009 and a 5% increment in 2010.

11.1.3 CUSTOMERS GROWTH

EEPCO has made a policy change on new customers connection costs so that those who can not cover the costs at once get credit that will be payable within three years. This has created an influx of customers as there were many customers who used to buy their power from meter lords being unable to pay this initial costs.

Target and Moderate scenario:

EEPCO initialises the forecast of customer number on the basis of 843 340 domestic and commercial customers in ICS in 2005, and assumes that 150,000 new customers will be connected to the existing system in 2006 for both Moderate and target scenarios.

The resulting annual growth rate of customers between 2005 and 2006 is then assumed to slowly decline and converge to the average population growth in 2018 (ie. 3% growth rate per year).

This coupled with the number of customers coming from the assumptions on the ongoing rural electrification will bring the total of new connections to more than 450 000 in the first five years of the period, indicating that this figure needs to be revised.

As described previously the existing system forecast is divided into three separate models.

Module 3: Energy Sector Profile and Projections

Vol 3: Ethiopia

These are:

- the Base ICS (Model1),
- earliest extensions (Model2),
- and the recent extensions (Model3).

To converge to the 3% annual growth rate of population in a 12 year-period, starting from the 2005 customer growth rate, EEPCO had used the following growth rates in the three models.

Year	Model		Model2		Model3	
	Dom (%)	Com (%)	Dom (%)	Com (%)	Dom (%)	Com (%)
2006	12.72%	17.24%	22.38%	9.36%	25.52%	12.27%
2007	11.28%	14.90%	19.39%	8.72%	21.87%	11.18%
2008	10.00%	12.88%	16.80%	8.12%	18.74%	10.18%
2009	8.87%	11.14%	14.55%	7.57%	16.06%	9.27%
2010	7.86%	9.63%	12.61%	7.05%	13.76%	8.45%
2011	6.97%	8.32%	10.92%	6.57%	11.79%	7.69%
2012	6.18%	7.19%	9.46%	6.12%	10.10%	7.01%
2013	5.48%	6.22%	8.20%	5.70%	8.66%	6.38%
2014	4.86%	5.37%	7.10%	5.31%	7.42%	5.81%
2015	4.31%	4.65%	6.15%	4.95%	6.36%	5.29%
2016	3.82%	4.02%	5.33%	4.61%	5.45%	4.82%
2017	3.38%	3.47%	4.62%	4.29%	4.67%	4.39%
2018-30	3.00%	3.00%	4.00%	4.00%	4.00%	4.00%

Table 11-2 - EEPCO's Existing System Number of Customers Growth Assumptions

Low scenario:

These figures are revised with the following table in order to limit the 2006 new customers figure to 130 000 and the total of new connections to 280 000 in the first five years of the period.

Module 3: Energy Sector Profile and Projections

Vol 3: Ethiopia

Year	Model		Model2		Model3	
	Dom (%)	Com (%)	Dom (%)	Com (%)	Dom (%)	Com (%)
2006	11.03%	14.94%	19.40%	8.11%	22.12%	11.03%
2007	9.89%	13.07%	17.01%	7.65%	19.18%	9.89%
2008	8.88%	11.43%	14.91%	7.21%	16.63%	8.88%
2009	7.96%	10.00%	13.07%	6.80%	14.42%	7.96%
2010	7.15%	8.75%	11.46%	6.41%	12.51%	7.15%
2011	6.41%	7.65%	10.05%	6.04%	10.85%	6.41%
2012	5.75%	6.70%	8.81%	5.70%	9.41%	5.75%
2013	5.16%	5.86%	7.72%	5.37%	8.16%	5.16%
2014	4.63%	5.12%	6.77%	5.06%	7.07%	4.63%
2015	4.15%	4.48%	5.94%	4.77%	6.13%	4.15%
2016	3.73%	3.92%	5.20%	4.50%	5.32%	3.73%
2017	3.34%	3.43%	4.56%	4.24%	4.61%	3.34%
2018-30	3.00%	3.00%	4.00%	4.00%	4.00%	3.00%

Table 11-3 - Low demand scenario Existing System Number of Customers Growth Assumptions

11.1.4 RURAL ELECTRIFICATION APPROACH

Target and Moderate scenario:

With the objective of increasing the level of electricity access and thereby assisting the socio-economic development of the rural population, the Ethiopian Government, through EEPKO has launched a rural electrification program. The program aims at increasing the current 15% access rate to 50% within a 5-year period of time. Identification of towns using high resolution maps have been completed. Around 7 000 towns are identified. The planning work is yet completed, therefore all the necessary information are not available.

Low scenario:

A 15 years implementation period is assumed rather than the 5 years implementation period assumed in the EEPKO's forecast. No adjustment is made on the methodology and other assumptions.

11.2 ASSUMPTIONS IDENTICAL FOR TARGET, MODERATE AND LOW SCENARIO

11.2.1 ECONOMIC GROWTH

A government forecast by the Ministry of Finance and Economic Development (MOFED), projects annual non-agricultural GDP growth at 7.64 to 6.9% over the next three years based

Module 3: Energy Sector Profile and Projections

Vol 3: Ethiopia

on strong growth in the two major sectors (Industrial and Services). As in the case of EEPCO's moderate scenario the three years average of MOFED's predication is used to determine the future Non-Agricultural GDP growth rates in the low scenario.

Year	Industrial	Services	Remark
2006	7.64	6.90	MOFED
2007	7.98	6.89	MOFED
2008	7.98	6.88	MOFED
2009-2030	7.9	6.90	Average MOFED

Table 11-4 - GDP Growth Rates for the low and moderate scenario

11.2.2 RURAL ELECTRIFICATION

11.2.2.1 Population

The demand for electricity within a rural community is dictated by the absolute number of potential consumers in the community. The first step in this calculation is a forecast of the total population over the study period.

The forecast is made based on an overall 3% population growth estimate.

11.2.2.2 Occupants per House

The population forecast was converted to the total number of potential connections by dividing the population by the average number of occupants per house. This information was available in the 1996 survey of household income for urban centres. This overall average is 4.7 persons per household. For this forecast, a household is assumed to be equivalent to a census housing unit as well as equivalent to one customer connection.

11.2.2.3 Market Penetration

Data for electrified small urban centres indicate that approximately 40% of the households are connected to the system. In addition, not all households will be connected within the first years of electrification. Thus, an initial connection rate of 10% was determined and a growth curve over 10 years to the ultimate connection rate was developed based on the available data.

Considering the policy change in the connection fee the initial value is now raised to 20% while the ultimate connection rate is raised to 60% within 10 years.

11.2.2.4 Average Residential Consumption

The conversion of potential connections into electricity forecasts required information on consumption per connection.

A review of 16 recently electrified towns indicates that the residential consumption per residential customer is in the order of 304 kWh/yr. Data at 8 established ICS centres were reviewed to determine growth rates for consumption per customer. The rate established is 2.57% per year. This growth rate does not include the growth in the number of customers, which is estimated separately.

11.2.2.5 Average Non-residential Consumption

Consumption patterns in population centres with electrical supply were reviewed to determine the relationship between residential and non-residential use. Non-residential use includes commercial, street lighting and small industrial activities.

No large industrial activity is assumed for the load centres under study. Annual non-residential consumption is estimated at 176 kWh for small commercial, 6 kWh for street lighting and 216 kWh for small industries. There are no explicit forecasts for the number of customers in each of these categories, therefore these average consumption rates are based on the number of domestic customers. Total non-residential consumption is 399 kWh per year.

Commercial consumption per customer is assumed to rise at 2.98% per year, while the annual growth in industrial consumption per customer is 1.65%.

The domestic growth rate (2.57%) was also adopted for the street lighting load. Again, these growth rates do not include the growth in the number of customers, which are estimated separately.

Sales estimates for both the residential and non residential use in this forecast are made based on the consumption level and the growth rates derived from the above study.

11.2.3 SCS CENTERS TRANSFERED TO THE ICS WITHING THE STUDY PERIOD

A number of current SCS centres are scheduled for connection to the ICS over the forecast period. These extensions include:

Module 3: Energy Sector Profile and Projections

Vol 3: Ethiopia

SCS Center	Full First Year	Voltage (KV)
Negele Borena	2006	66
Abi Adi	2006	33
Nefas mewcha	2006	33
Gambella	2010	132
Dembi Dollo	2010	132
Gore	2010	132
Metu	2010	132
Tenta	2007	33
Wereilu	2007	33
Alem Ketema	2006	33
Gineer	2006	33
Bonga	2006	132
Mizan Teferi	2006	132
Teppi	2006	132
Mehal Meda	2007	66
Molalie	2007	66
Metema	2007	132
Jinka	2006	132
Asossa	2007	132
Nedjo	2007	132
Dubti	2009	230
Assaita	2009	230

Table 11-5 - Schedule for transfer of SCS centres to ICS

11.2.4 SELF-CONTAINES SYSTEM (SCS)

Currently supplied SCS centres are forecast to grow at an average annual rate of 7%. This rate is based on the observed rates of growth in the consumption per of customer (2.1%) and in the number of customers (2.5%) based on growth at two established SCS centres (Nekempt and Negele Borena). Those SCS centres which are connected to the ICS during the forecast period are forecast at the above rates until the date of interconnection and at the Model 3 rates from the date of interconnection.

11.2.5 INCOME AND PRICE ELASTICITY

The income and price elasticity considered in the low scenario are the same as in the Target and Moderate EEPSCO scenarios.

11.2.6 STREET LIGHTING SALES

Street Lighting sales represent a small and volatile portion of total demand. For purposes of this forecast, street lighting is assumed to represent a fixed portion of total sales over the entire forecast period. For Model 1 centres this fixed percentage is 1.25%, for Model 2 it is 1.5% and for Model 3, 2%.

11.2.7 GENERATION AND POWER DEMAND FORECAST

The sales forecasts determined for each branch are converted to a net energy generation requirement on the basis of the average system loss rate.

The loss rate is assumed to decline from the present level of 18.5% to 15% dropping every year by 0.5%.

The associated peak demand is determined using an average system load factor of 57.5% for the ICS.

11.3 FORECAST RESULTS

The ICS existing system forecast is the sum of all defined branches forecasts in each year over the forecast period. On top of this, the rural electrification demand is added to determine the future ICS demand.

Similarly, the SCS forecast is also the sum of all defined SCS branches, plus rural electrification less those branches transferred to the ICS.

The total ICS sales and net generation forecast for the Low is presented as Appendix M3-Vol3-3 Table 7.

Module 3: Energy Sector Profile and Projections

Vol 3: Ethiopia

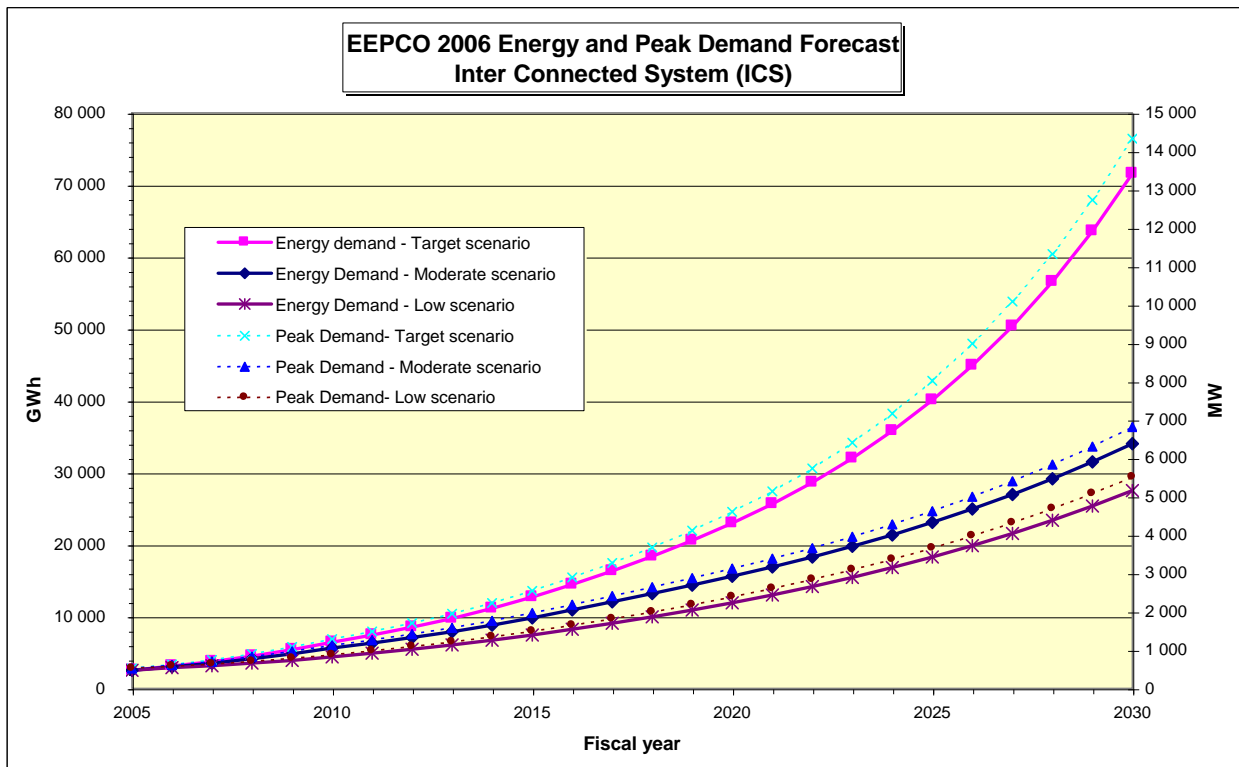

Figure 11.3-1 - EEPCO 2006 Energy and Peak Demand Forecast Inter Connected System (ICS)